

ITEM NO	PART NUMBER	QTY	DESCRIPTION
1	532086E	1	METER BAR 1" METER THREAD LLB
2	581812E	2	RISER SUB ASSEMBLY W/ SADDLE NUT

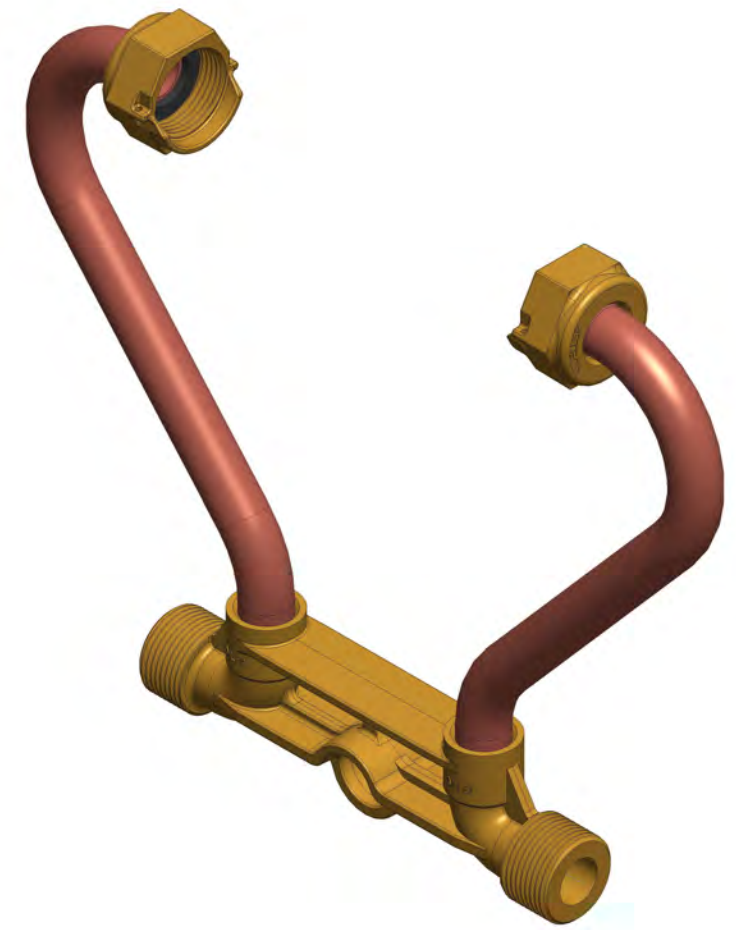
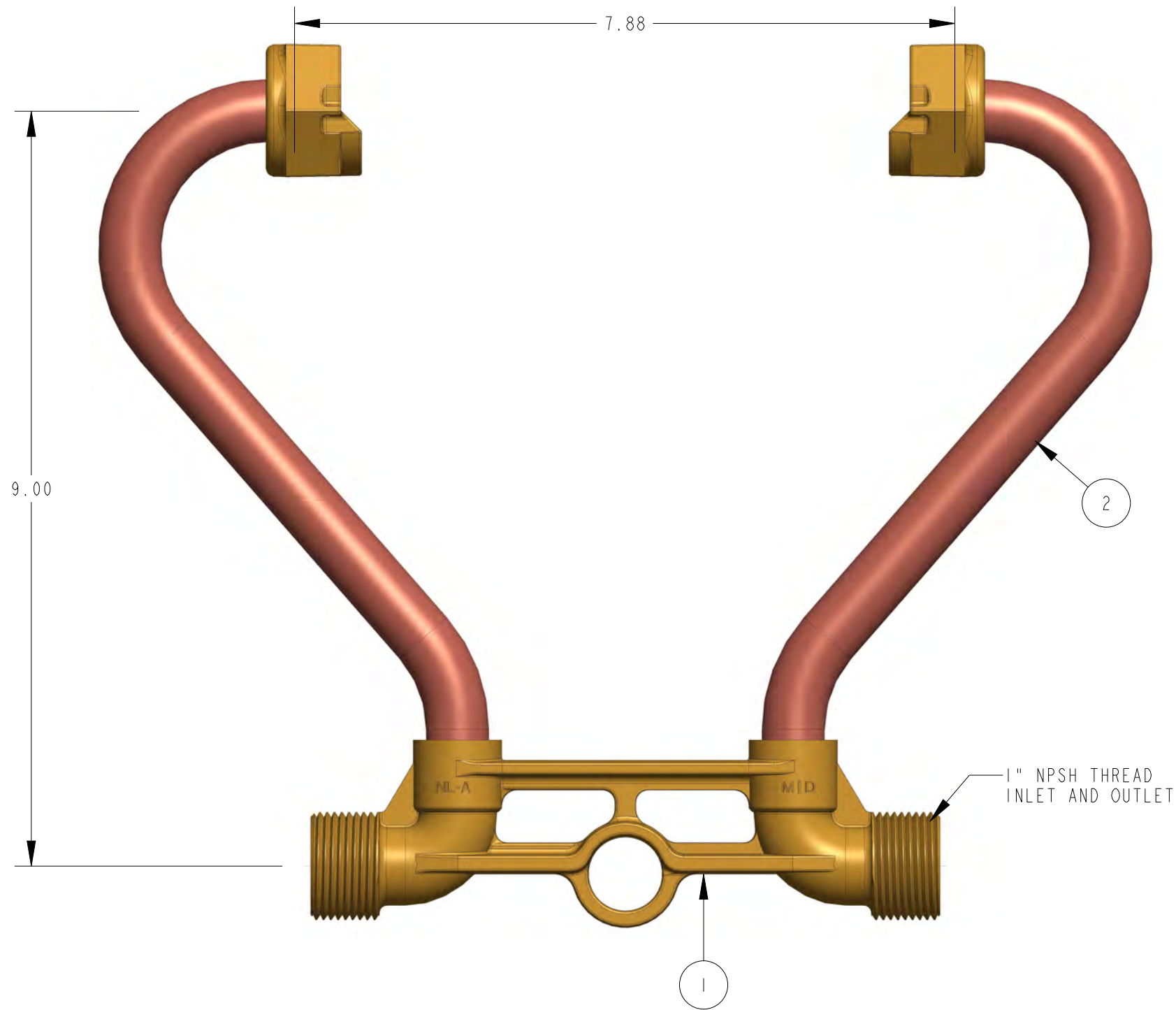

DR. BY	AOD	11/02/21	UNLESS OTHERWISE NOTED	THIRD ANGLE PROJECTION	C.B. NO.
CHKR			BREAK CAST CORNER(S)---		
ENGR			BREAK MACH CORNER(S)---	PURCH.	PATT. NO.
MGR			TOLERANCES	FINISH	
MFG			UNLESS OTHERWISE NOTED	REF. NO.	SCALE
TOOL			LINEAR		NONE
FDRY			±	ANGULAR	±
MAT'L:				STK. NO.	
MUELLER			DESCR. 5/8" X 3/4" COPPER METER SETTER 9" RISER HEIGHT LOW LEAD BRASS	NUMBER	236H14114-----N

236H14114-----N