

ITEM NO	PART NUMBER	QTY	DESCRIPTION
1	508551_PART_	1	BASE TRAY
2	508553_PART_	1	9" BOX UPPER SECTION
3	544495	1	TOUCH READ LID
4	250H14234N	1	3/4" HANDWHEEL EXPANSION
5	250H15428	1	3/4" SERVICE FITTING
6	508563E	1	3/4" INSIDE IP THREAD OUTLET
7	680506N	1	5/8"X3/4" OR 3/4" METER VALVE ASSEMBLY

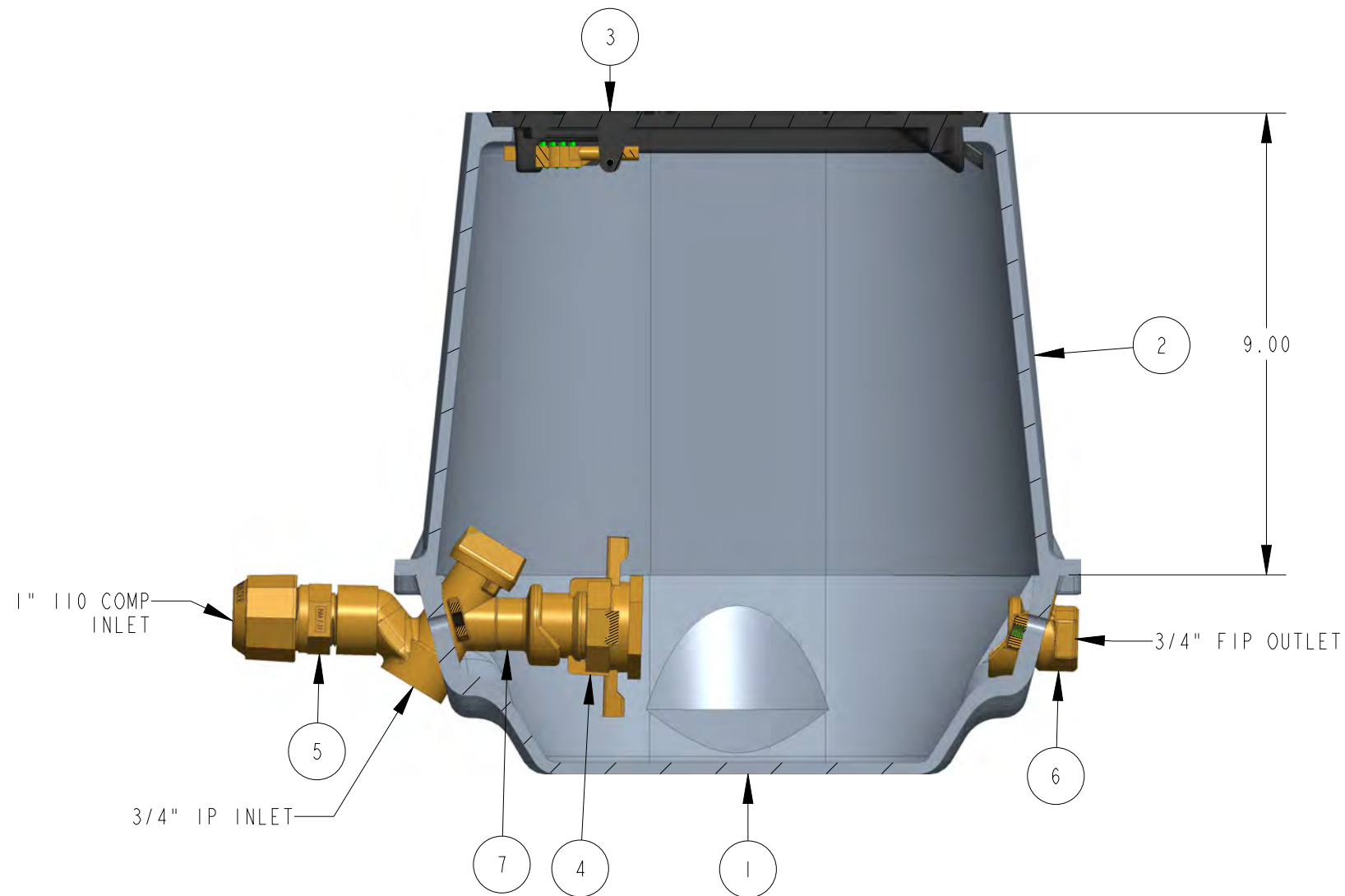

OPTION CODE 09:

*TOUCH READ LID

DR. BY	AOD	7/26/22	UNLESS OTHERWISE NOTED		THIRD ANGLE PROJECTION	C.B. NO.
CHKR			BREAK CAST CORNER(S)---			
ENGR			BREAK MACH CORNER(S)---			
MGR			TOLERANCES		PURCH.	FINISH
MFG			UNLESS OTHERWISE NOTED		REF. NO.	SCALE
TOOL			LINEAR	ANGULAR	NONE	
FDRY			±	±	STK. NO.	
MAT'L:						
			DESCR. 5/8"X3/4" CAST IRON METER BOX			NUMBER
			9" HEIGHT			236H1452--K-09N
			LOW LEAD BRASS			

236H1452--K-09N