

ITEM NO	PART NUMBER	QTY	DESCRIPTION	MATERIAL
1	508551_PART_	1	BASE TRAY	CAST IRON
2	508553_PART_	1	9" BOX UPPER SECTION	CAST IRON
3	544495	1	TOUCH READ LID	CAST IRON
4	250H14234N	1	3/4" HANDWHEEL EXPANSION	LEAD FREE BRASS ALLOY ASTM B584 C89833/C87850
5	508563E	1	3/4" INSIDE IP THREAD OUTLET	LEAD FREE BRASS ALLOY ASTM B584 C89833/C87850
6	682386N	1	3/4" IRON MTR BOX BV	LEAD FREE BRASS ALLOY ASTM B584 C89833/C87850

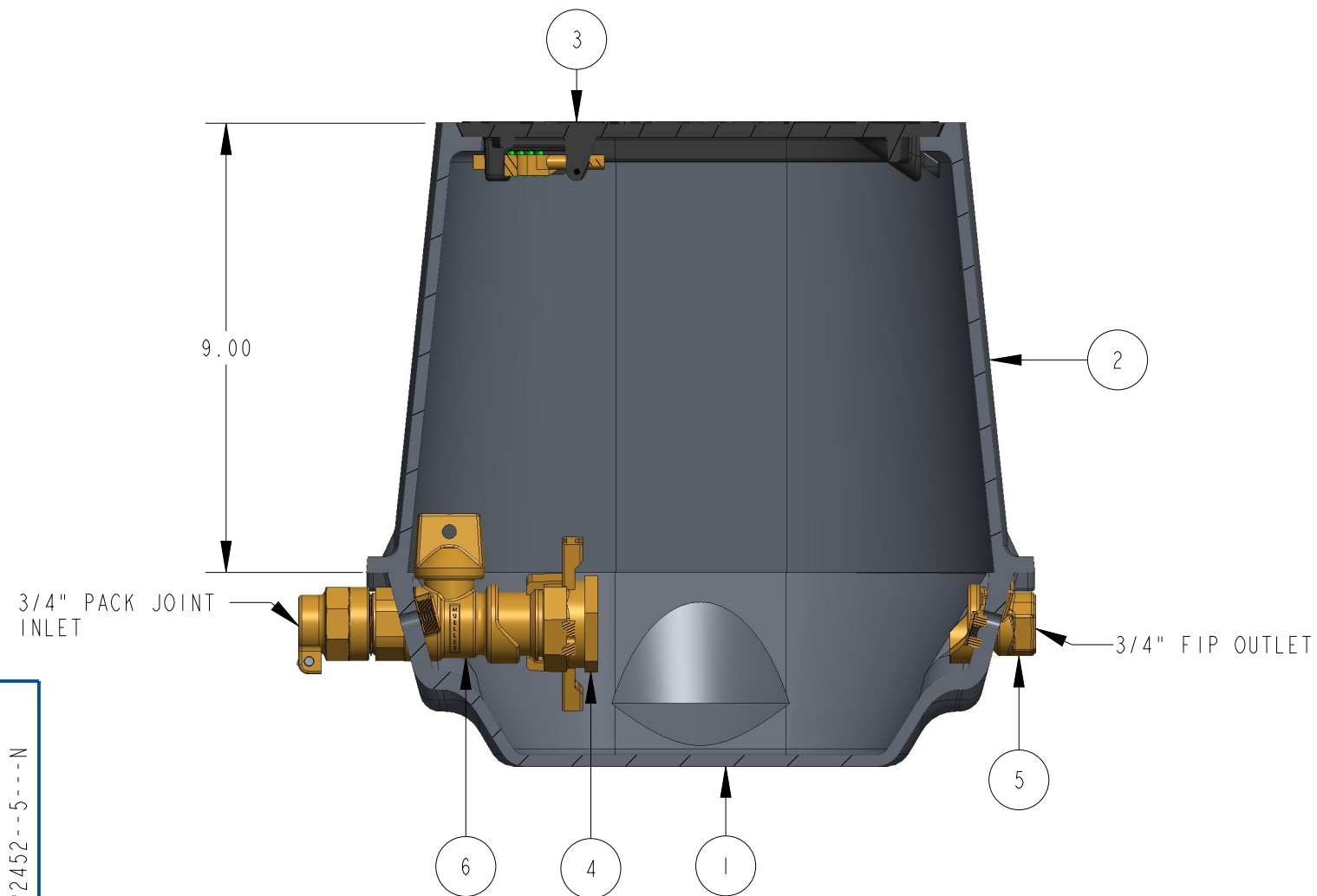
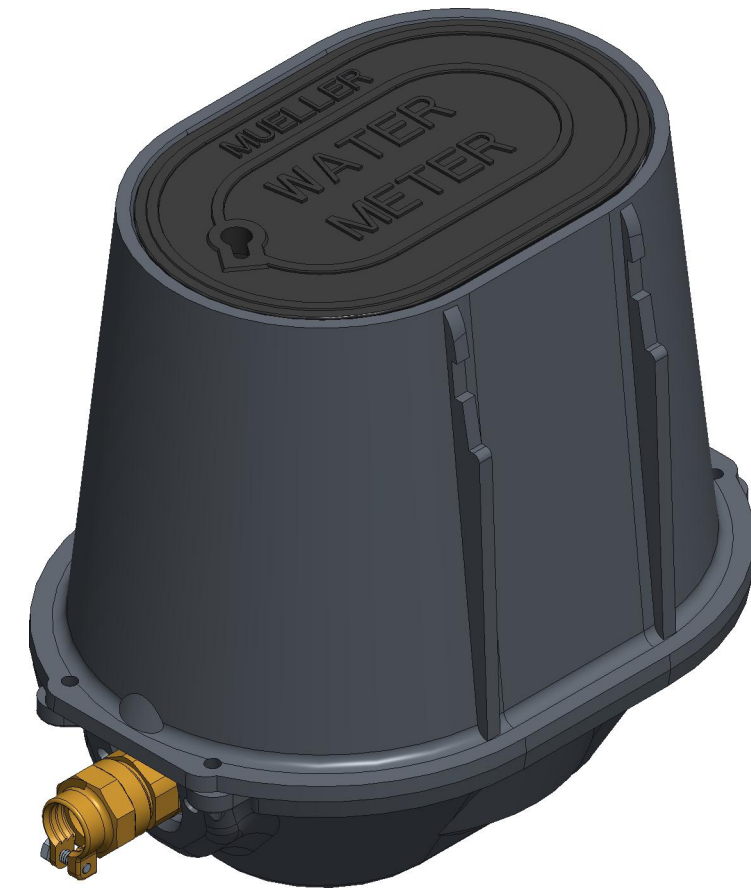

DR. BY	JBK	11/17/22	UNLESS OTHERWISE NOTED	THIRD ANGLE PROJECTION	C.B. NO.
CHKR			BREAK CAST CORNER(S)---		
ENGR			BREAK MACH CORNER(S)---	PURCH.	PATT. NO.
MGR			TOLERANCES	FINISH	
MFG			UNLESS OTHERWISE NOTED	REF. NO.	SCALE
TOOL			LINEAR		NONE
FDRY			±	ANGULAR	±
MAT'L:				STK. NO.	
MUELLER			DESCR. 5/8" X 3/4" CAST IRON METER BOX 9" HEIGHT LOW LEAD BRASS	NUMBER	236P2452--5--N

236P2452--5--N