

250AD184860LBBSN

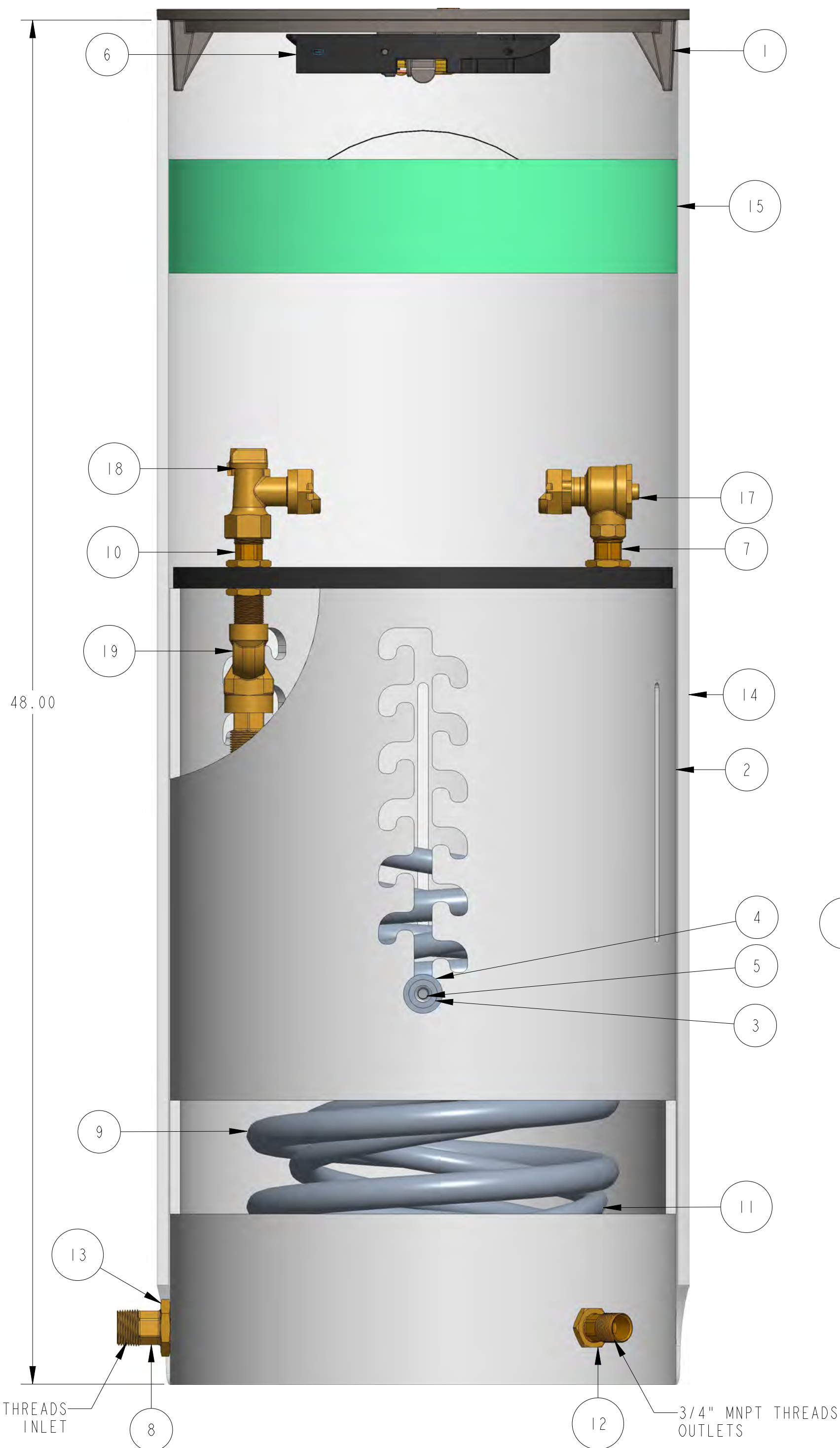

ITEM NO	PART NUMBER	QTY	DESCRIPTION
1	282925	1	18" DIA CAST IRON SIDE LOCKING LID (SOLD SEPARATELY)
2	545215-1812	1	17" INSIDE CARTRIDGE - 12" RISE
3	545216	3	T-NUT
4	545217	3	STAINLESS STEEL WASHER
5	545529	3	1/2" SHOULDER BOLT
6	548357	2	15" & 18" UNIVERSAL BRACKET
7	700013_REVE	4	3/4" HOSE CONNECTOR
8	700014	2	1" HOSE CONNECTOR
9	700046-1860	1	COIL PART WITH LL BRASS CONNECTORS
10	700131	2	3/4" NIPPLE WITH WRENCH FLATS
11	780012-1560	2	3/4" COIL PART
12	790006	12	3/4" HEX NUT
13	790010	2	1" HEX NUT
14	790011-1848	1	18" ADJUSTA-SHELL ASSEMBLY 48"-60"
15	790153	1	18" INSULATION PAD (SOLD SEPARATELY)
16	790299	1	18" PLATFORM
17	215H14244	2	5/8" X3/4" DUAL CHECK VALVE
18	215H14265	2	3/4" ANGLE BALL VALVE
19	402H15367N	1	1IN X 3/4IN FIP THREAD U-BRANCH

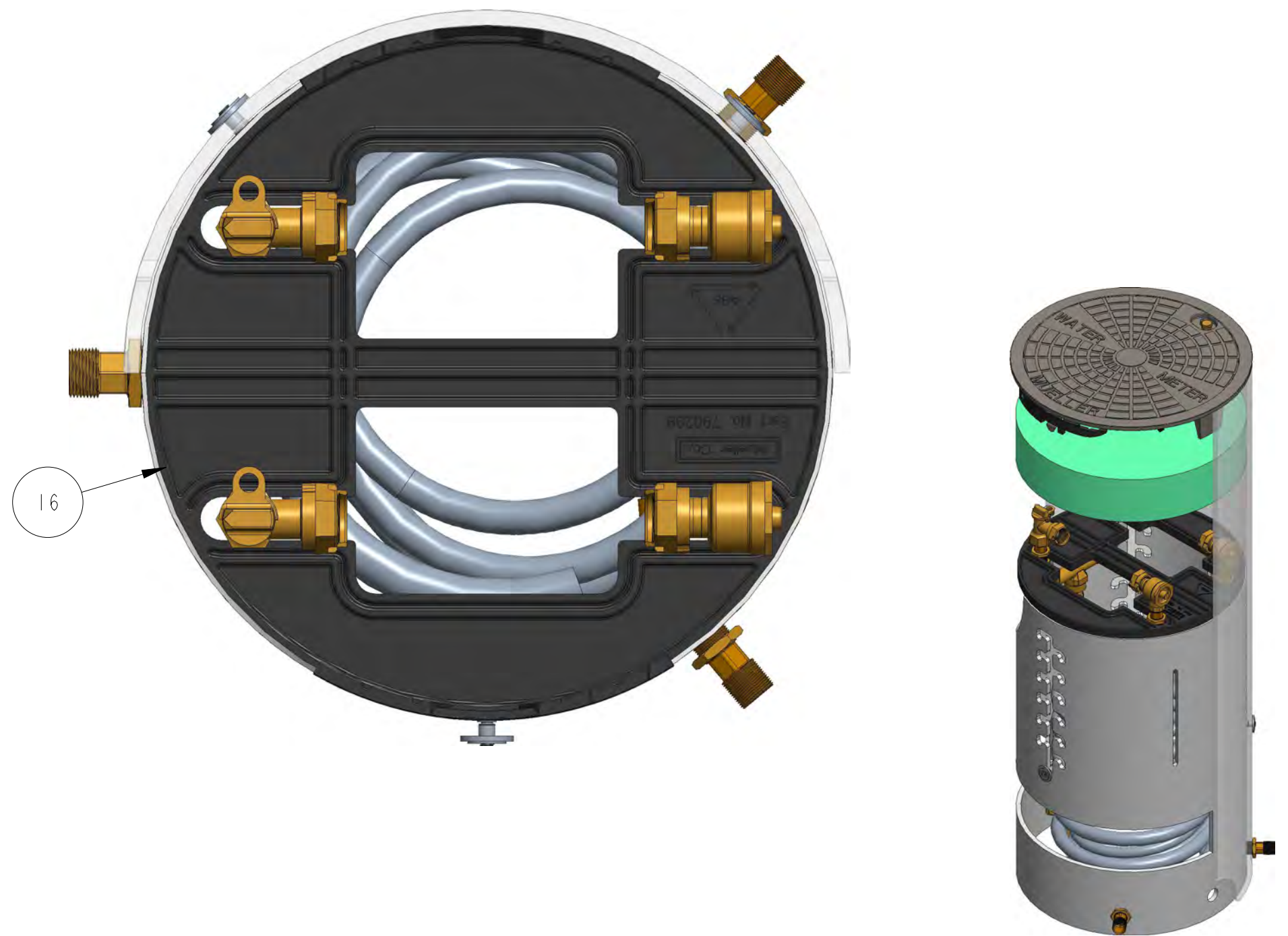

DR. BY	AOD	4/22/22	UNLESS OTHERWISE NOTED	THIRD ANGLE PROJECTION	C.B. NO.
CHKR			BREAK CAST CORNER(S)---		
ENGR			BREAK MACH CORNER(S)---	PURCH.	FINISH
MGR			TOLERANCES	REF. NO.	SCALE
MFG			UNLESS OTHERWISE NOTED	STR. NO.	
TOOL			LINEAR	ANGULAR	
FDRY			±	±	
MAT'L:		DESCR: 3/4" ADJUSTABLE DOUBLE METER PIT 18" DIA X 48-60" DEPTH LOW LEAD BRASS		NUMBER 250AD184860LBBSN	
MUELLER					