

ITEM NO	PART NUMBER	QTY	DESCRIPTION	MATERIAL
1	311955	1	18" DIA SIDE LOCKING COMPOSITE LID (SOLD SEPARATELY)	COMPOSITE MATERIAL
2	311981	1	ABS PLATFORM 18-40	PLASTIC VIRGIN POLYLAC, PA747 ABS BLACK RESIN OR PROOFED EQUIVALENT RESIN
3	548357-RIVET	2	LID LOCK BRACKET	ABS PLASTIC
4	566456-1848	1	SHELL BODY	SDR-51 PVC PIPE ASTM D2241 GRADE 1120
5	700013	4	3/4" HOSE CONNECTOR	RED BRASS ASTM B43 ALLOY C23000 O61 TEMPER ANNEALED
6	700020-RIVET	1	INTERNAL PLATFORM RING	SDR-51 PVC PIPE ASTM D2241 GRADE 1120
7	700035-1548	2	3/4" COIL PART	POLYBUTYLENE RESIN BASSELL AKOALIT PB4267 OR 4237 GREY
8	790006	8	3/4" HEX NUT	ASTM B16 ALLOY C36000
9	790153	1	18" INSULATION PAD (SOLD SEPARATELY)	ETHAFOAM 220 WHITE OR POLYLAM 1.7 DENSITY WHITE
10	01424451_A215N	1	5/8" X 3/4" ASSE DUAL CHECK VALVE	LEAD FREE BRASS ALLOY ASTM B584 C89833/C87850
11	02426551__215N	1	5/8" X 3/4" FULL PORT BALL VALVE	LEAD FREE BRASS ALLOY ASTM B584 C89833/C87850

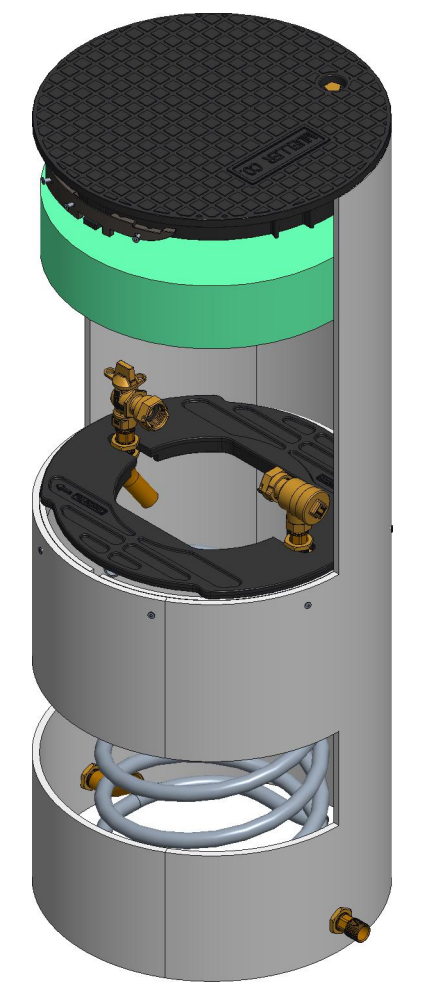
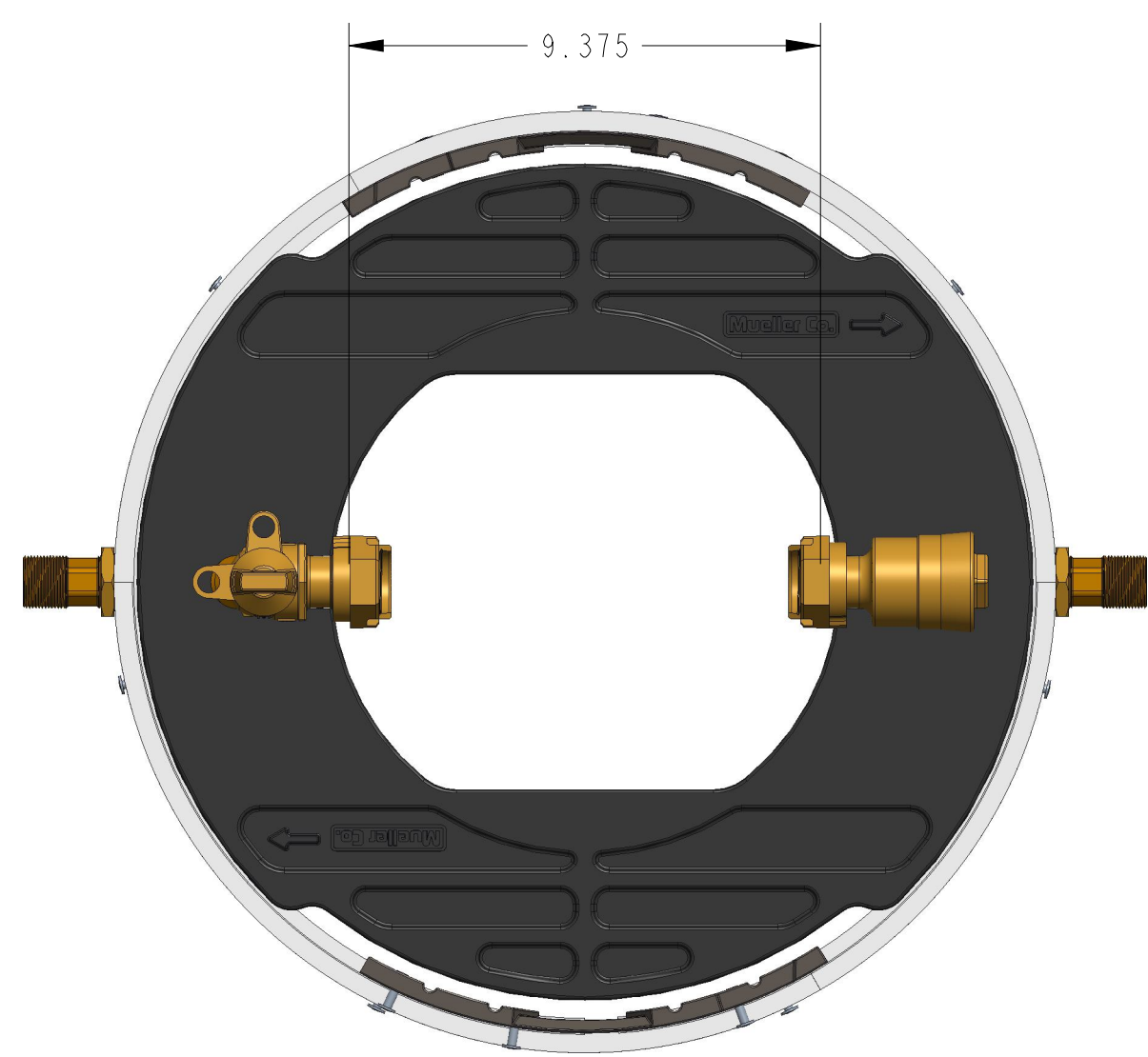
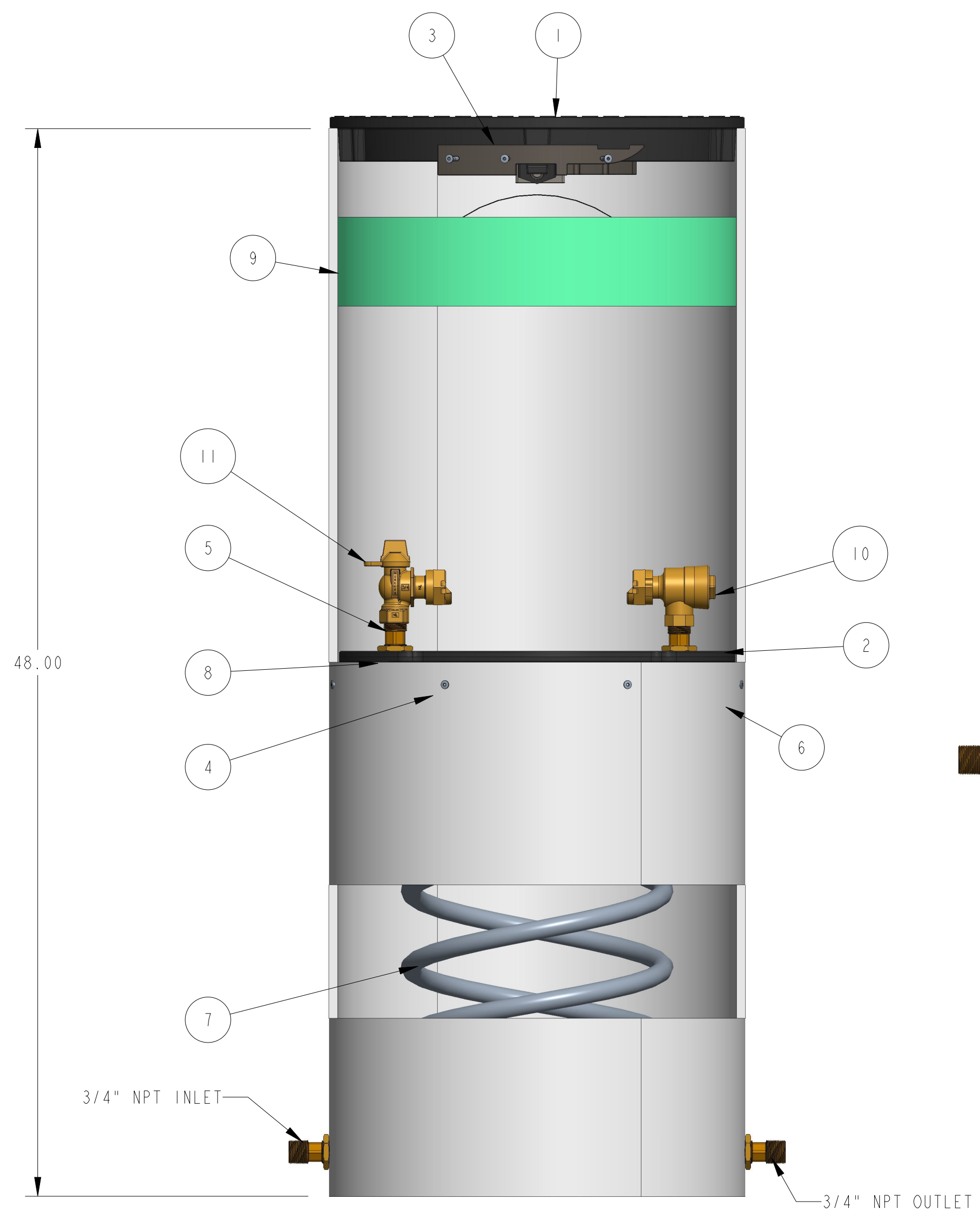

REVISIONS					
REV	ECR	DESCRIPTION	DRAWN BY	DATE	APPROVED
A		RELEASE	AOD	8/25/21	
B		UPDATED SHELL	JBK	10/13/25	

TITLE TO AND OWNERSHIP OF THIS ENGINEERING DATA REMAINS IN Mueller Co. ABSENT ON THE PART OF THE RECIPIENT TO THESE CONDITIONS IS PRESUMED.

INTERPRET THIS DRAWING IN ACCORDANCE WITH ASME Y14.5 2018		NAME	DATE	THIRD ANGLE PROJECTION	
UNLESS OTHERWISE SPECIFIED DIMENSIONS ARE IN INCHES. MACHINING TOLERANCES:		DRAWN BY	AOD	8/25/21	
X ±.1	.XX ±.015	D.E. APPR.			TITLE: 3/4" COIL SINGLE METER PIT 18" DIA X 48" DEPTH LEAD FREE BRASS
.XXX ±.005		M.E. APPR.			
ANGULAR CORNER BREAK FINISH	±1° .015/.025 125 µin. RA	Q.A. APPR.			
MATERIAL:		DO NOT SCALE DRAWING		SIZE	DWG. NUMBER
STK NUMBER:	REF.NO.	SCALE: 0.063		WT:	REV
					250CS1848FSBSN
					B
				SHEET	1 OF 1