

250RD2148RVBSN

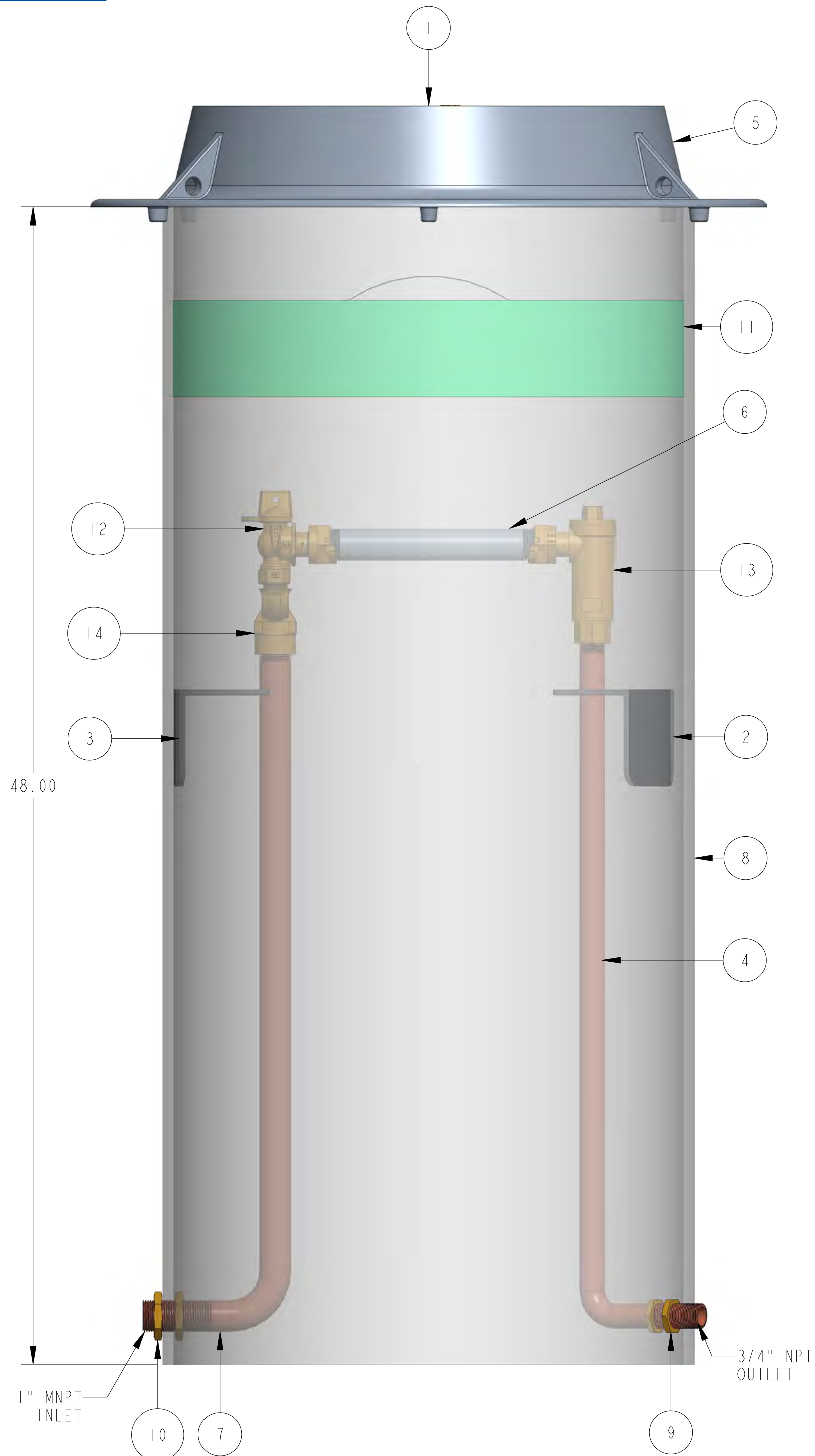

ITEM NO	PART NUMBER	QTY	DESCRIPTION
1	282925	1	18" DIA CAST IRON SIDE LOCKING LID (SOLD SEPARATELY)
2	546396	2	3/4" SUPPORT BRACKET
3	547400	1	1" SUPPORT BRACKET
4	700064-1544	2	RISER
5	700098-1	1	CAST IRON FRAME (PURCHASED SEPARATELY)
6	700251	2	3/4" METER JUMPER
7	700338	1	RISER
8	780058-2148	1	SHELL SUB ASSEMBLY
9	790006	4	3/4" HEX NUT
10	790010	2	1" HEX NUT
11	790119	1	21" X 4" INSULATION PAD (SOLD SEPARATELY)
12	215B2426551RN	2	5/8" X 3/4" REDUCED PORT BALL VALVE
13	215H14460AN	2	5/8" X 3/4" VERTICAL ASSE APPROVED CHECK VALVE
14	400H15365N	1	1" INLET X 3/4" OUTLET U-BRANCH

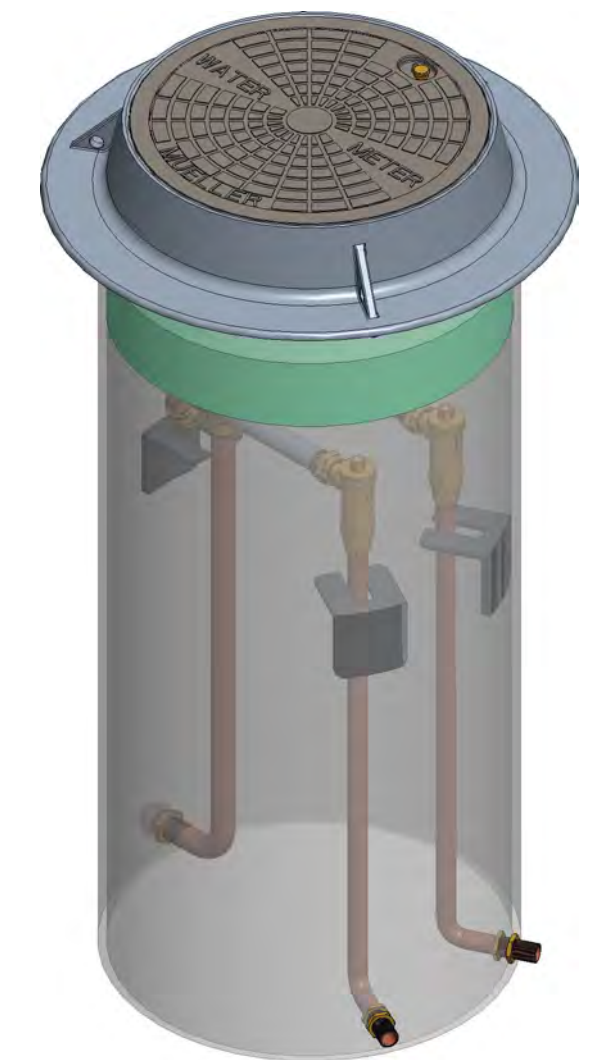
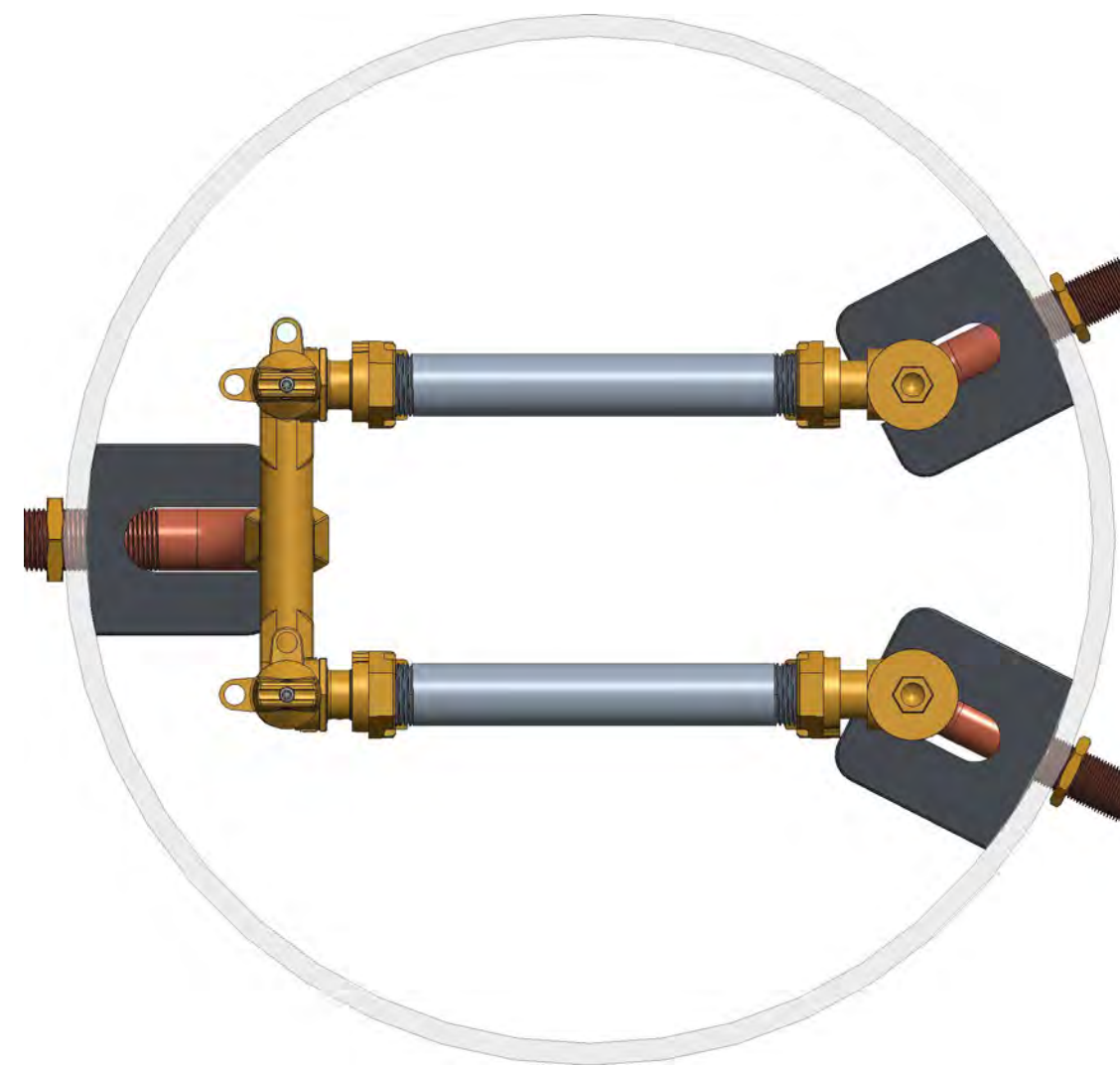

DR. BY	AOD	2/17/22	UNLESS OTHERWISE NOTED	THIRD ANGLE PROJECTION	C.B. NO.
CHKR			BREAK CAST CORNER(S)---		
ENGR			BREAK MACH CORNER(S)---	PURCH.	FINISH
MGR			TOLERANCES	REF. NO.	SCALE
MFG			UNLESS OTHERWISE NOTED	STR. NO.	PATT. NO.
TOOL			LINEAR	ANGULAR	
FDRY			±	±	
MAT'L:					
MUELLER			DESCR. 3/4" RIGID DOUBLE METER PIT 21" DIA X 48" DEPTH LOW LEAD BRASS		NUMBER 250RD2148RVBSN