

ITEM NO	PART NUMBER	QTY	DESCRIPTION	MATERIAL
1	311633	2	3/8" - 16 HEX NUT	BRASS ALLOY ASTM B16 C36000
2	527366	2	CAST IRON METER BAR	CAST IRON ASTM A126 CLASS B
3	527369	1	SPACER BAR	BRASS ALLOY ASTM B16
4	552189	1	1" U BAR	RED BRASS ASTM B43 ALLOY C23000 O6I TEMPER ANNEALED
5	330B24273N	1	1" ANGLE FULL PORT BALL VALVE	LEAD FREE BRASS ALLOY ASTM B584 C89833/C87850
6	330H14214N	2	1" METER COUPLING	LEAD FREE BRASS ALLOY ASTM B584 C89833/C87850
7	330H1446605AN	1	1" VERTICAL ANGLE CHECK VALVE	LEAD FREE BRASS ALLOY ASTM B584 C89833/C87850

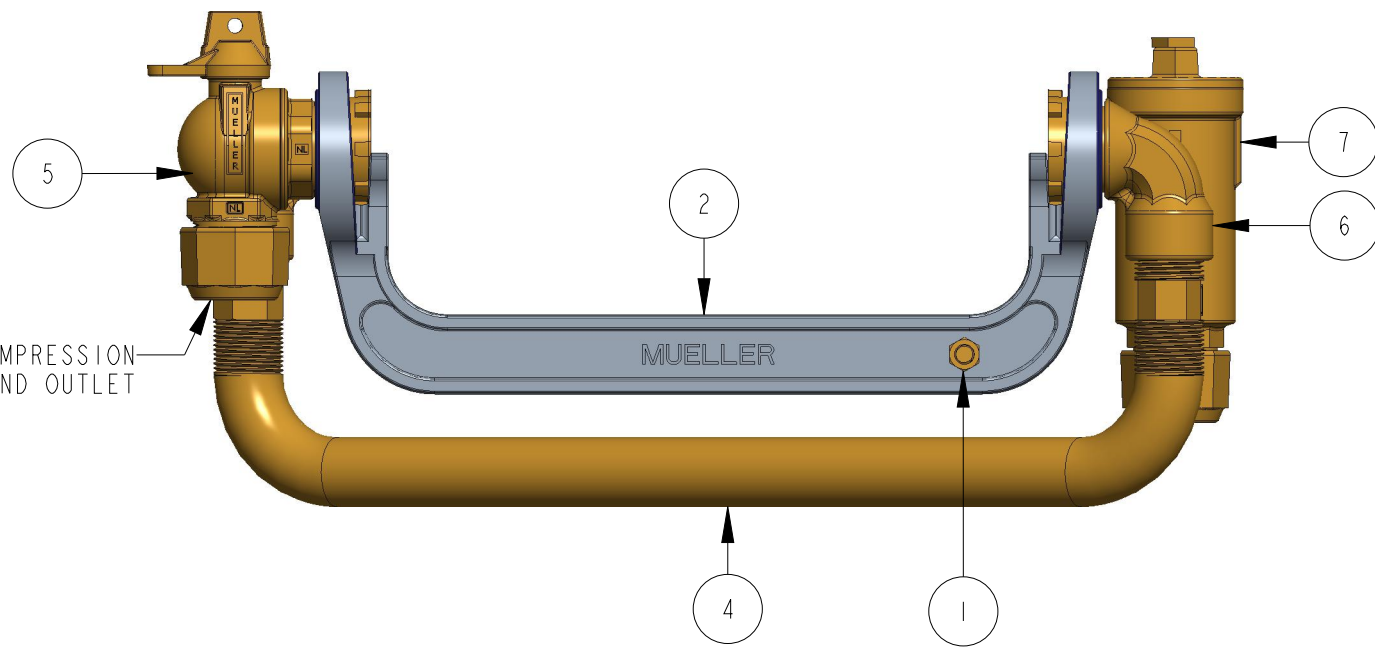
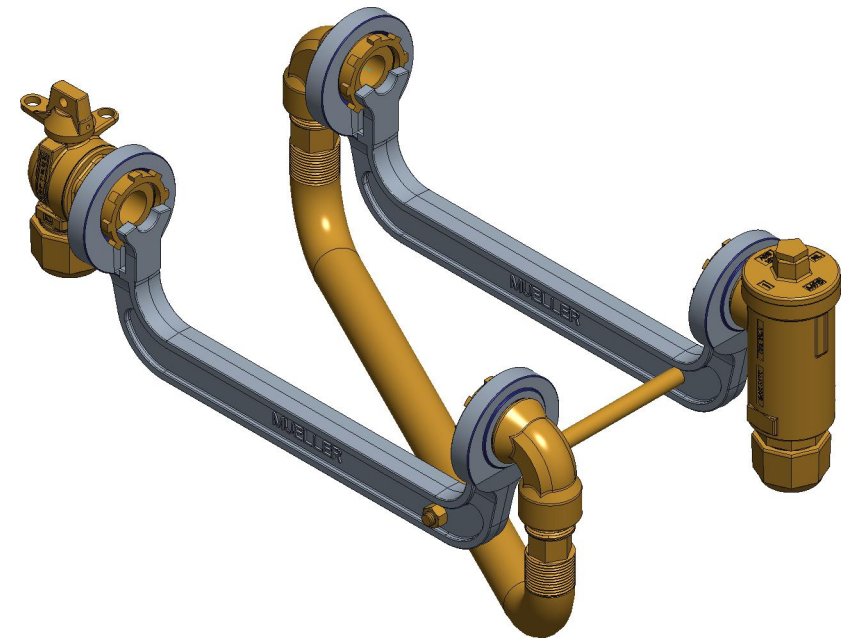
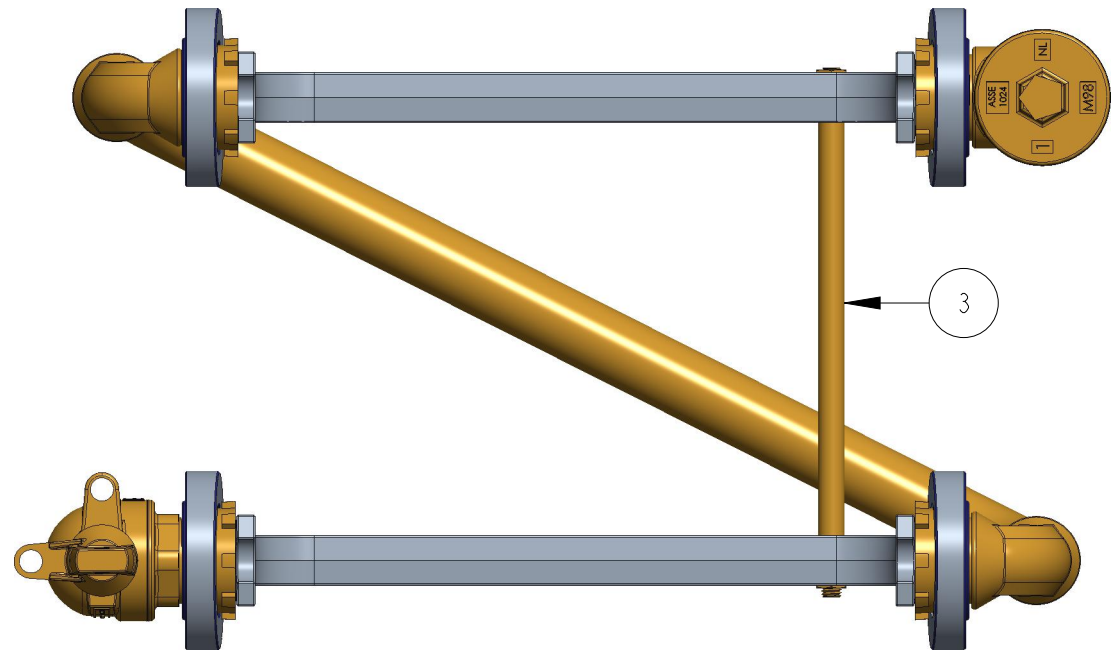

1" 110 COMPRESSION INLET AND OUTLET

OPTION CODE 00:

- *TANDEM 5000 SERIES
- *1" 110 CONNECTIONS ON INLET AND OUTLET

DR. BY	AOD	3/30/23	UNLESS OTHERWISE NOTED	THIRD ANGLE PROJECTION	C.B. NO.
CHKR			BREAK CAST CORNER(S)---		
ENGR			BREAK MACH CORNER(S)---	PURCH.	FINISH
MGR			TOLERANCES	REF. NO.	PATT. NO.
MFG			UNLESS OTHERWISE NOTED	SCALE	NONE
TOOL			LINEAR ±	ANGULAR ±	STK. NO.
FDRY					

MAT'L:



DESCR. 1" CAST IRON METER SETTER
LOW LEAD BRASS

NUMBER
330B5040--6A00N

330B5040--6A00N