

330CD2142FFBSN000715N

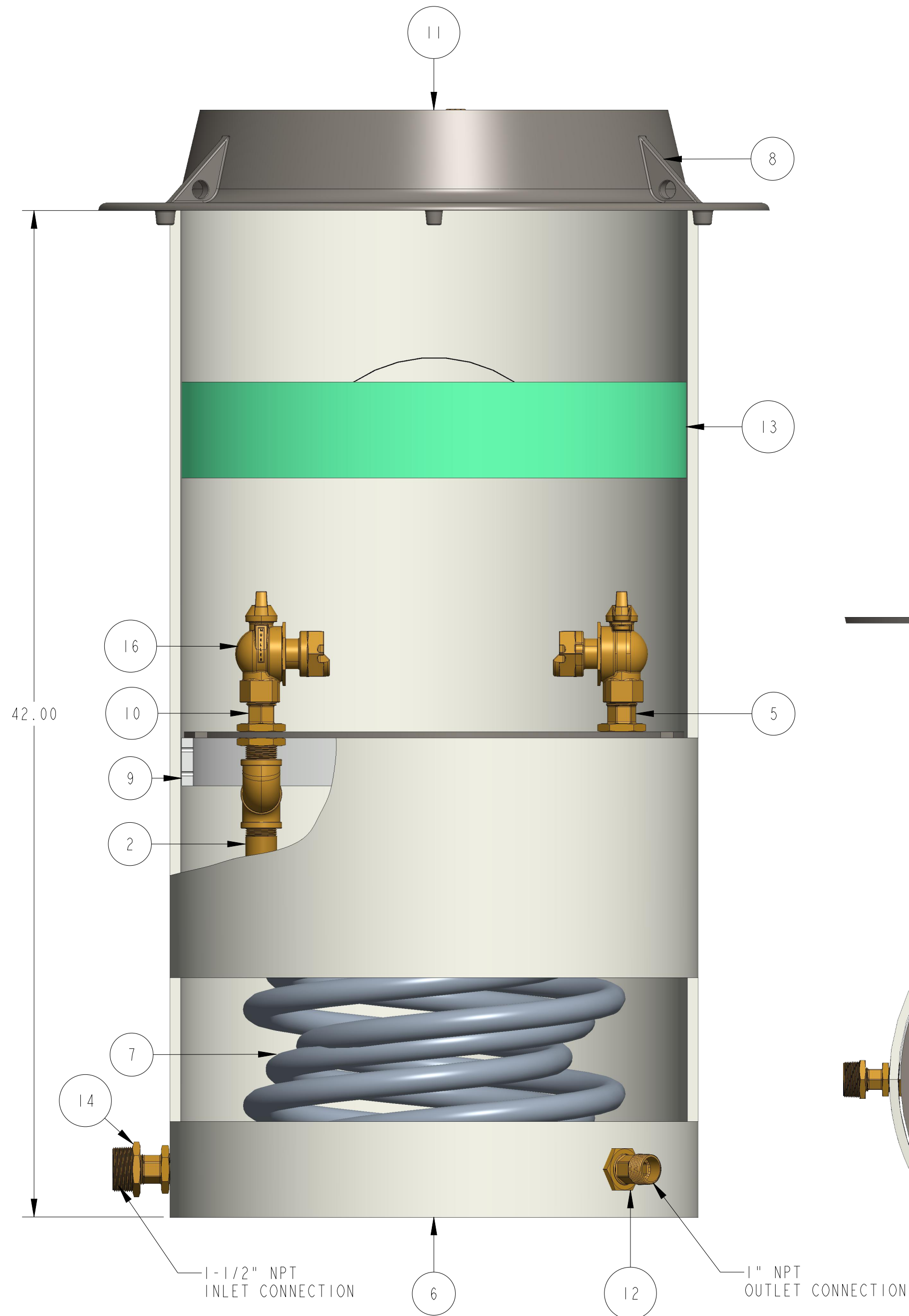

ITEM NO	PART NUMBER	QTY	DESCRIPTION
1	094987	2	1" FNPT ELBOW
2	548451	1	1" EXTENDED THREADED CONNECTOR
3	548593	1	21" STEEL PLATFORM
4	548605	2	1" NIPPLE
5	700014	5	1" HOSE CONNECTOR
6	700024-2142	1	SHELL SUB-ASSEMBLY
7	700046-1842	3	COIL PART
8	700098-1	1	CAST IRON FRAME (PURCHASED SEPARATELY)
9	700261	1	REINFORCING RING
10	700581	2	1" NIPPLE WITH FLATS
11	780113	1	18" DIA CAST IRON LID W/ RECESSED TR (SOLD SEPARATELY)
12	790010	14	1" HEX NUT
13	790322	1	21" X 4" EZ INSULATING PAD (ORDER SEPARATELY)
14	047169E	1	1" X 1-1/2" HEX BUSHING
15	094986E	1	1" FNPT THREADED TEE
16	330B24265	4	1" FULL PORT BALL VALVE

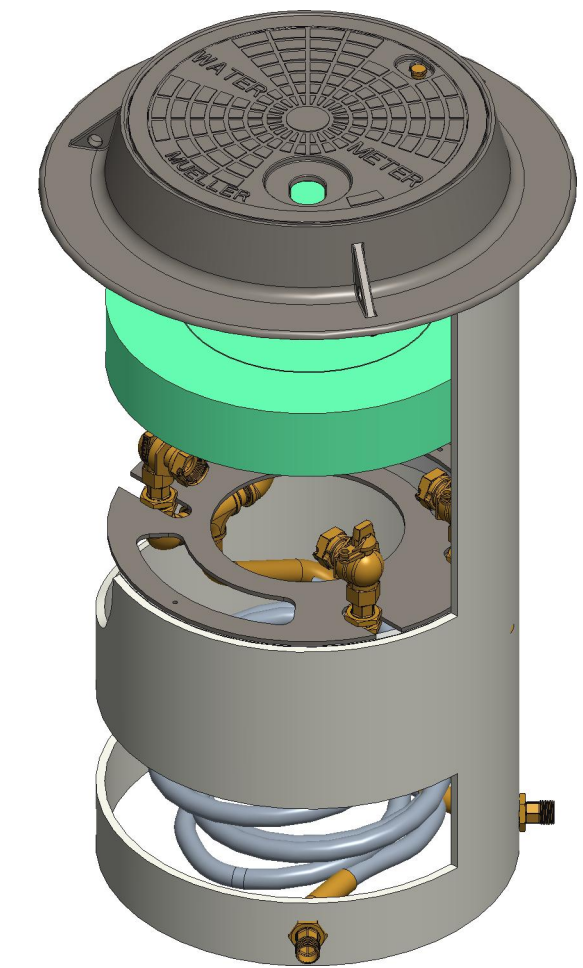
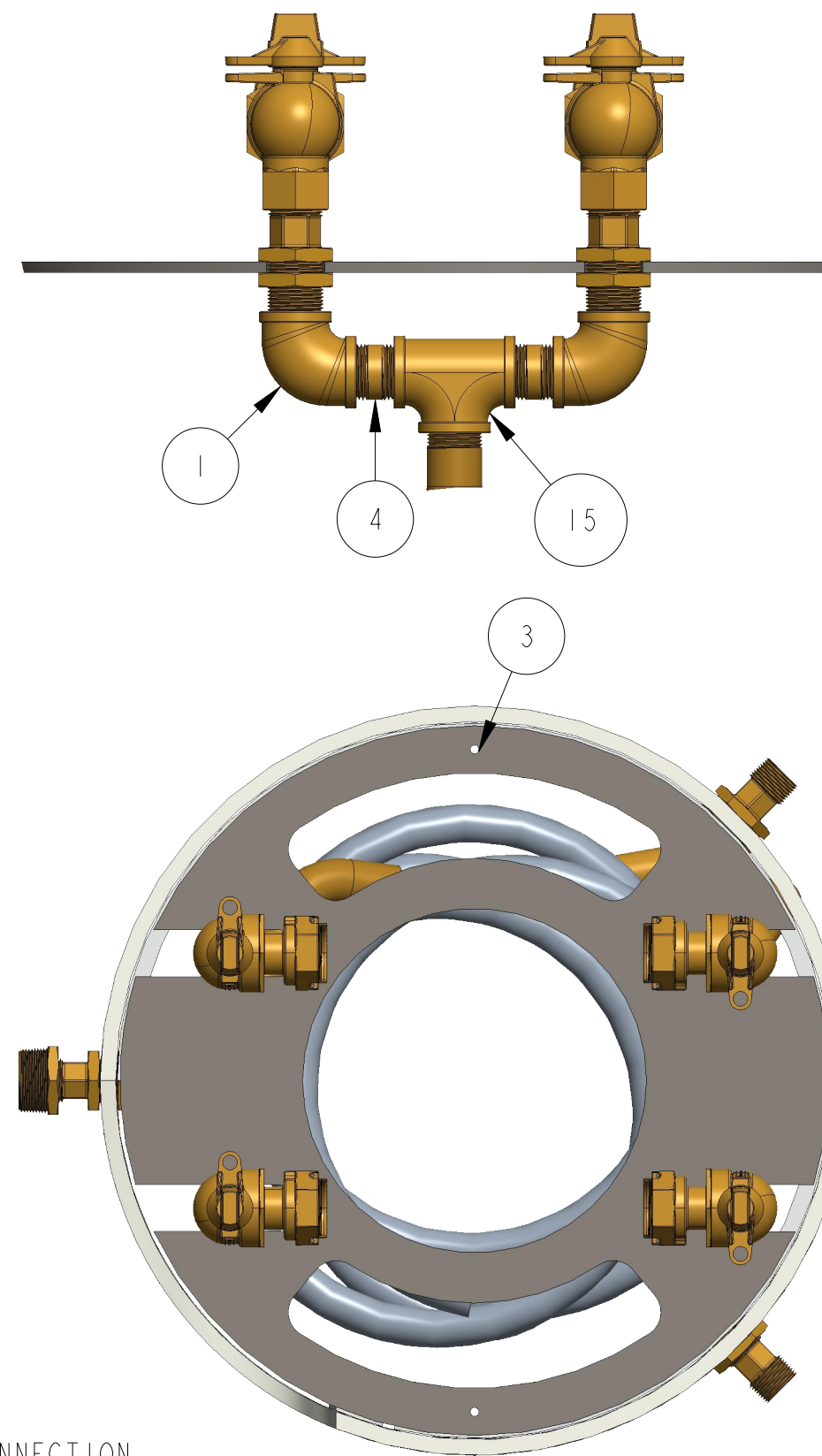

OPTION CODE 715:
*1-1/2" INLET

DR. BY	AOD	8/04/21	UNLESS OTHERWISE NOTED		THIRD ANGLE PROJECTION		C.B. NO.
CHKR			BREAK CAST CORNER(S)---				
ENGR			BREAK MACH CORNER(S)---		PURCH.	FINISH	PATT. NO.
MGR			TOLERANCES		REF. NO.	SCALE	
MFG			UNLESS OTHERWISE NOTED				
TOOL			LINEAR	ANGULAR			
FDRY			±	±	STR. NO.		
MAT'L:							
MUELLER			DESCR. 1" COIL DOUBLE METER PIT 21" DIA X 42" DEPTH LOW LEAD BRASS			NUMBER 330CD2142FFBSN000715N	