

ITEM NO	PART NUMBER	QTY	DESCRIPTION
1	061519	1	CAP
2	074959N	1	1" TEST VALVE
3	507863E	1	1" H-1436 METER YOKE BAR LOW LEAD
4	581832E	2	RISER SUB ASSEMBLY W/ SADDLE NUT

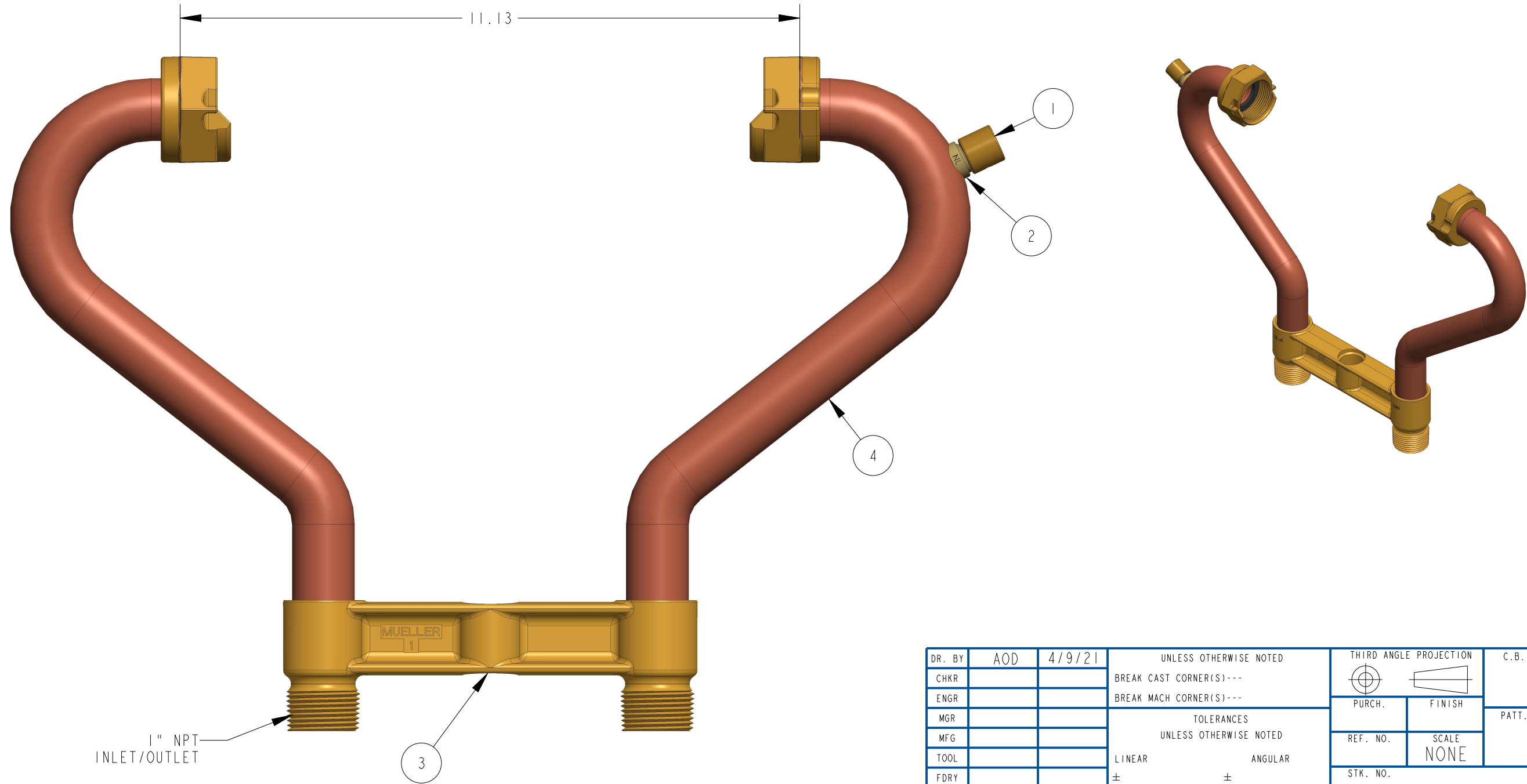

DR. BY	AOD	4/9/21	UNLESS OTHERWISE NOTED		THIRD ANGLE PROJECTION	C.B. NO.
CHKR			BREAK CAST CORNER(S)---			
ENGR			BREAK MACH CORNER(S)---		PURCH.	PATT. NO.
MGR			TOLERANCES		FINISH	
MFG			UNLESS OTHERWISE NOTED		REF. NO.	SCALE
TOOL			LINEAR	ANGULAR		NONE
FDRY			±	±	STK. NO.	
MAT'L:						
			DESCR. 1" COPPER YOKE SETTER WITH TEST VALVE LOW LEAD BRASS		NUMBER 330H1437-----N	

330H1437-----N