

ITEM NO	PART NUMBER	QTY	DESCRIPTION	MATERIAL
1	548399	1	MONITOR RING AND COVER	CLASS 30-35 GREY IRON
2	548403	1	EXPANDER RING	CLASS 30-35 GRAY IRON
3	548404	1	PLASTIC INNER FROST LID	MARINE GRADE POLYMER
4	20IN_LID	1	20" DIA LID	CAST IRON OR COMPOSITE

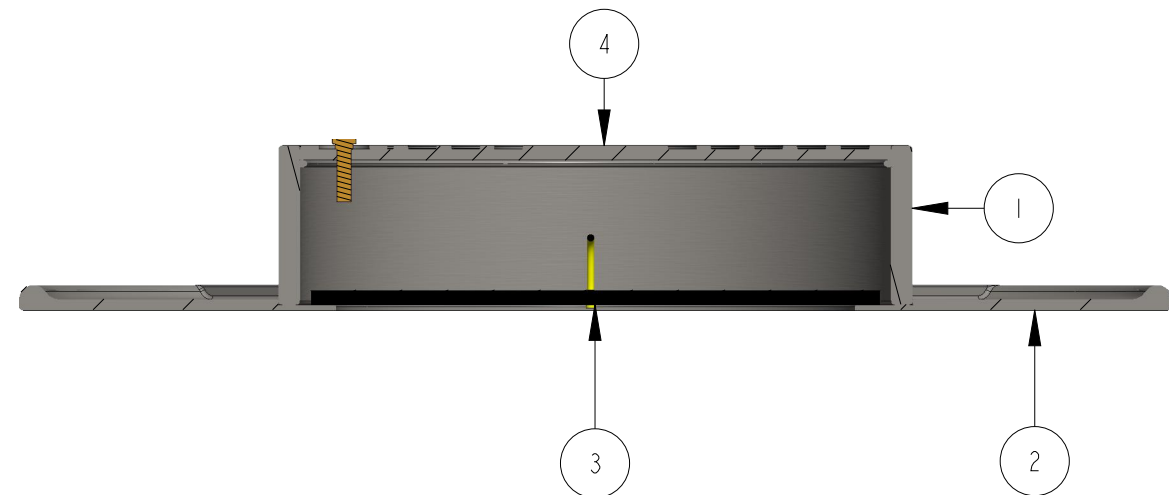
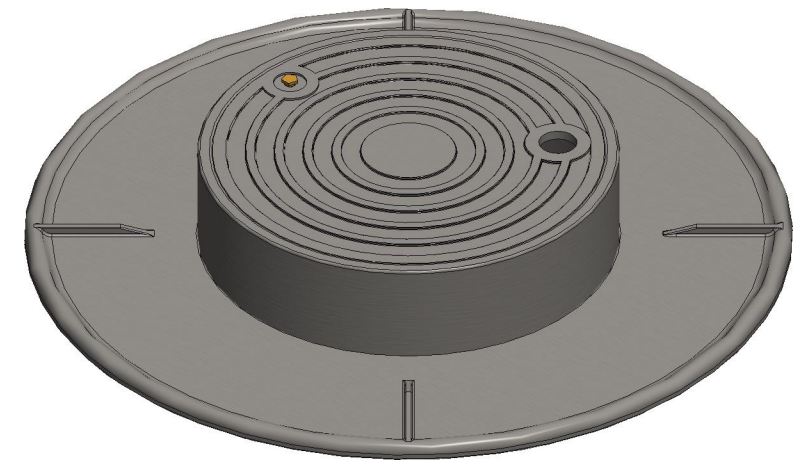
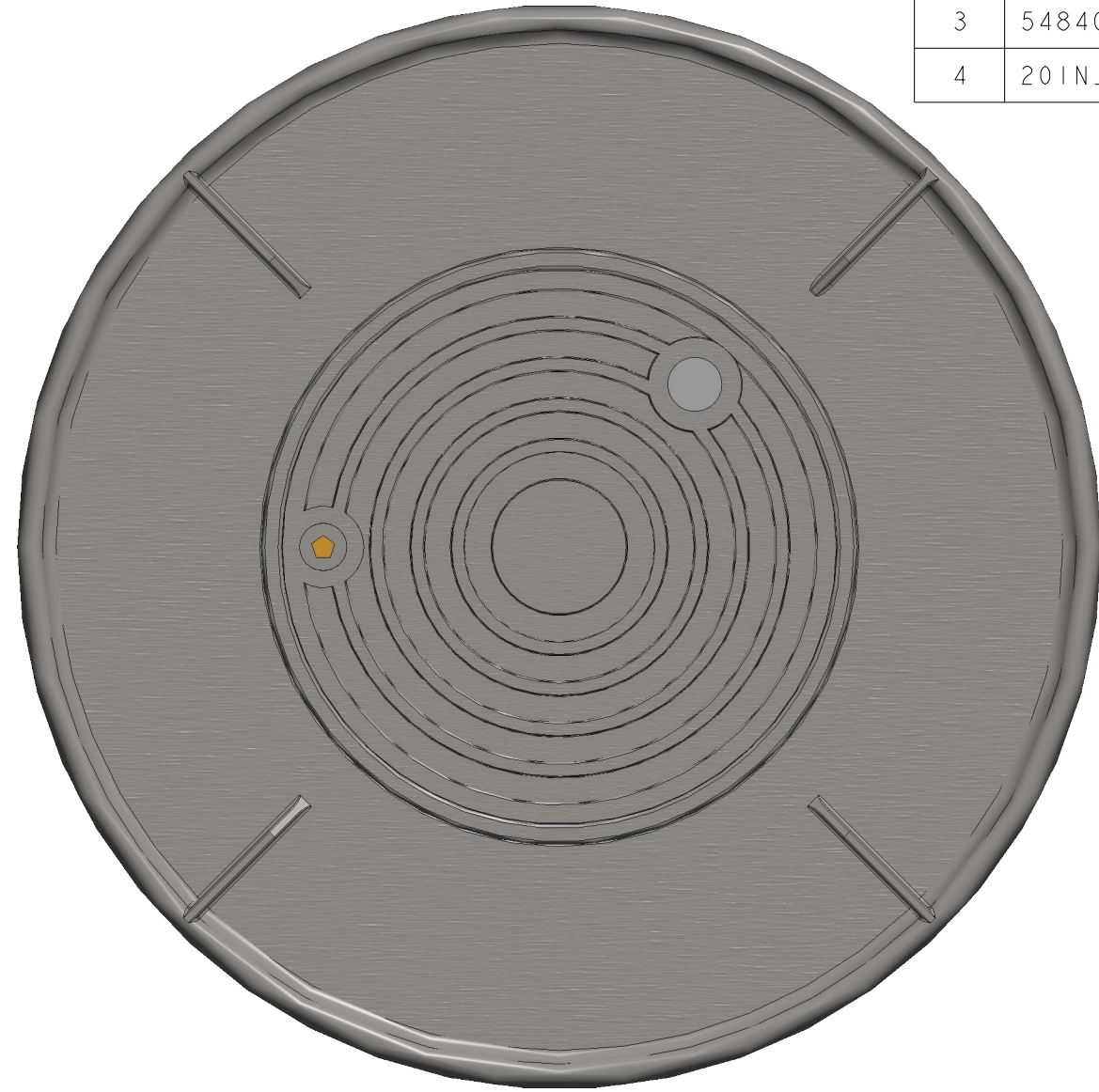

DR. BY	AOD	3/21/23	UNLESS OTHERWISE NOTED		THIRD ANGLE PROJECTION	C.B. NO.
CHKR			BREAK CAST CORNER(S)---			
ENGR			BREAK MACH CORNER(S)---			
MGR			TOLERANCES UNLESS OTHERWISE NOTED		PURCH.	FINISH
MFG			LINEAR	ANGULAR	REF. NO.	SCALE
TOOL			±	±	NONE	
FDRY					STK. NO.	
MAT'L:						
MUELLER			DESCR. $\varnothing 36''$ X $\varnothing 20''$ EXTENSION RING WITH TR LID		NUMBER 3620H1081409	

3620H1081409