

500 SERIES

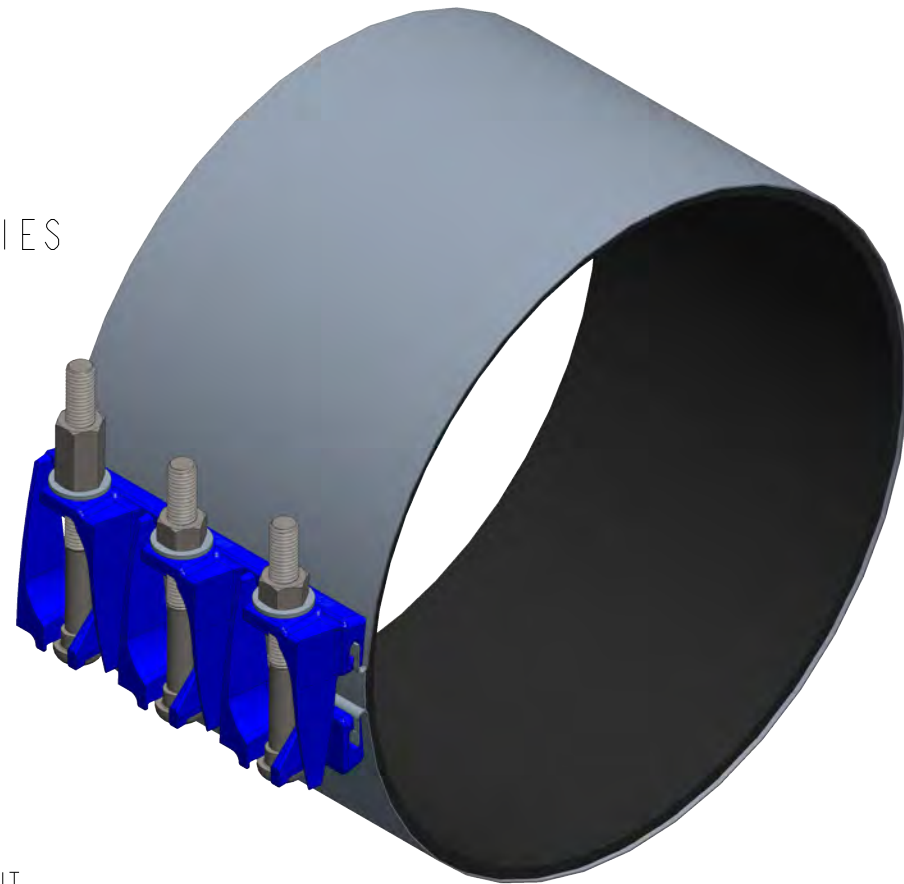

500 SERIES WITH SERVI-SEAL

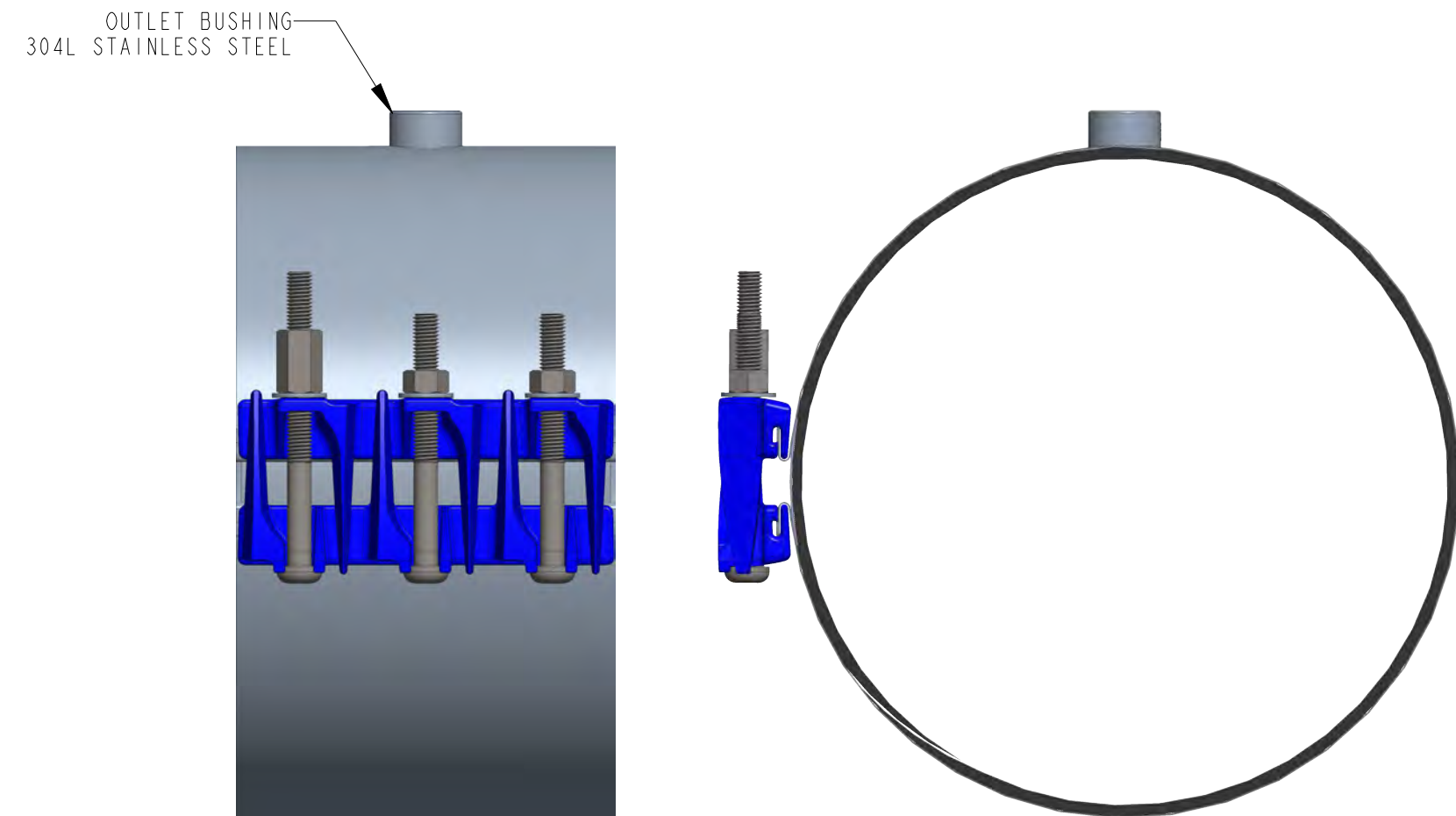
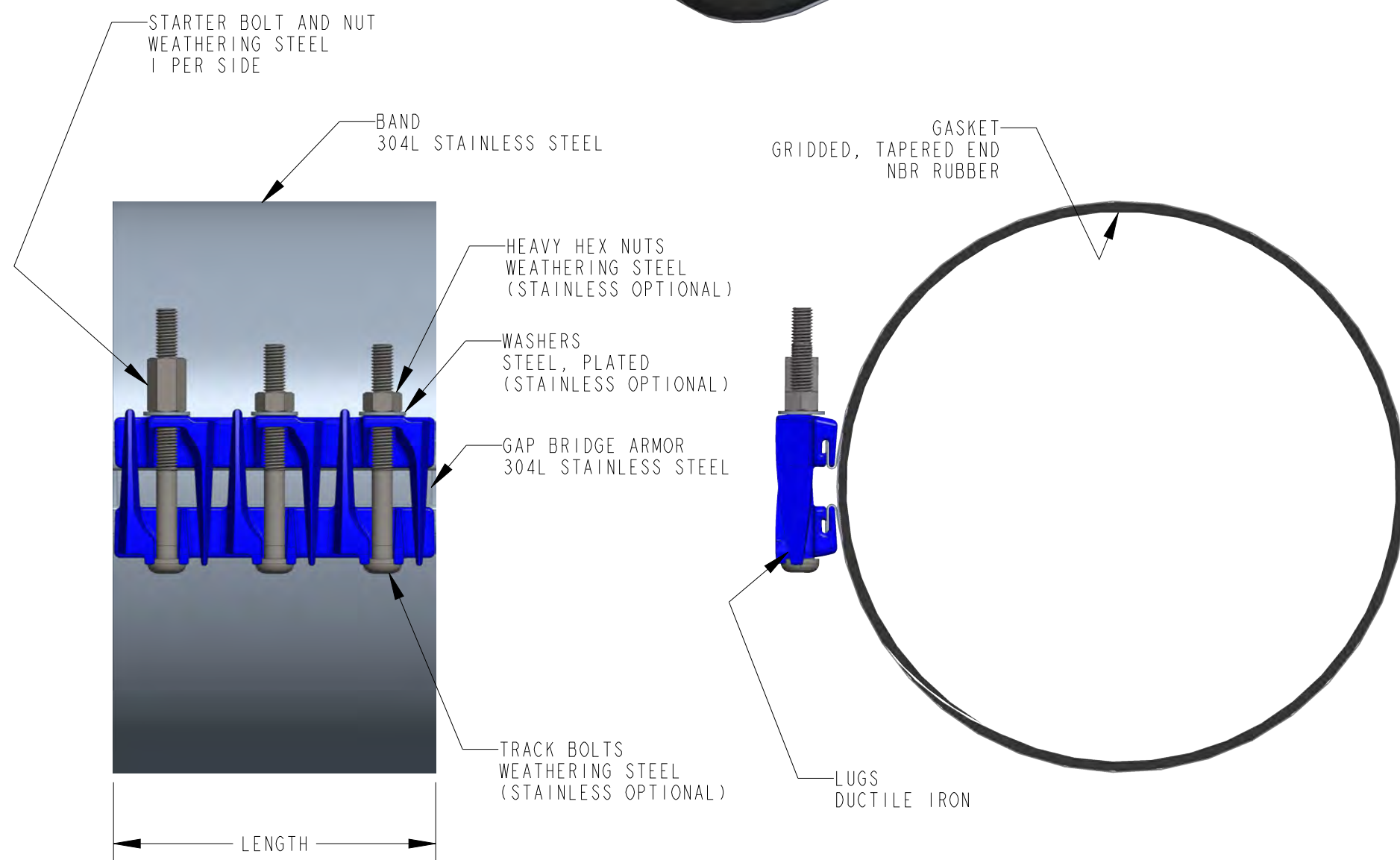
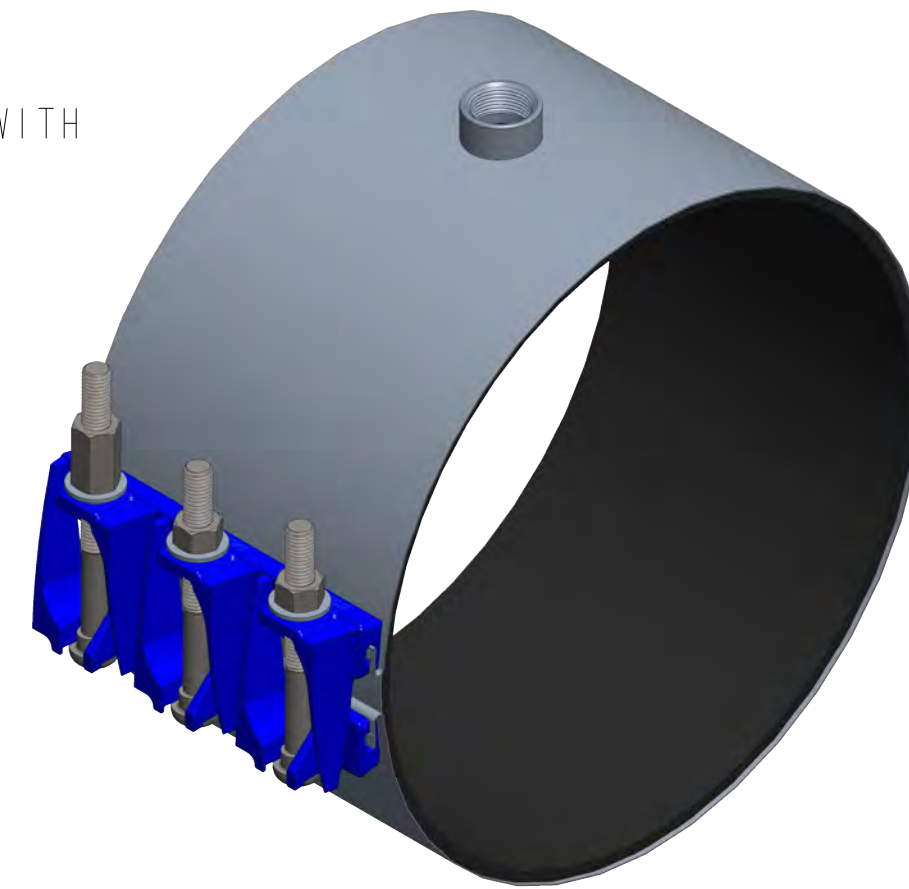

SERIES	STYLE
500	PLAIN CLAMP
501-509	CLAMP W/ SERVI-SEAL

AVAILABLE LENGTHS
6
7.5
9
10
12
15
18
20
24
30

STYLE NUMBER	SIZE AND TYPE OF TAP	O.D. RANGES AVAILABLE
500	NONE	2.35-14.40
501	3/4" IP	
502	3/4" CC	
503	1" IP	
504	1" CC	4.45-14.40
505	1-1/4" IP	
506	1-1/2" CC	
507	1-1/2" IP	
508	2" CC	
509	2" IP	

HOW TO GENERATE A CATALOG NUMBER				
SERIES	-	LENGTH	-	CLAMP SIZE NUMBER
500	-	07	-	0684

DR. BY CHKR ENGR MGR MFG TOOL FDRY	E.BAUMGARTNER 10/11/2021	UNLESS OTHERWISE NOTED BREAK CAST CORNER(S)--- BREAK MACH CORNER(S)---	THIRD ANGLE PROJECTION PURCH. FINISH REF. NO. SCALE STR. NO.	C.B. NO. PATT. NO.
MATERIAL:		TOLERANCES UNLESS OTHERWISE NOTED LINEAR ANGULAR ± ±		
Mueller Co.		DESCR. 500 SERIES REPAIR CLAMP SUBMITTAL DRAWING		NUMBER 500_SERIES.SUBMITTAL