

500VS2730FBB000733N

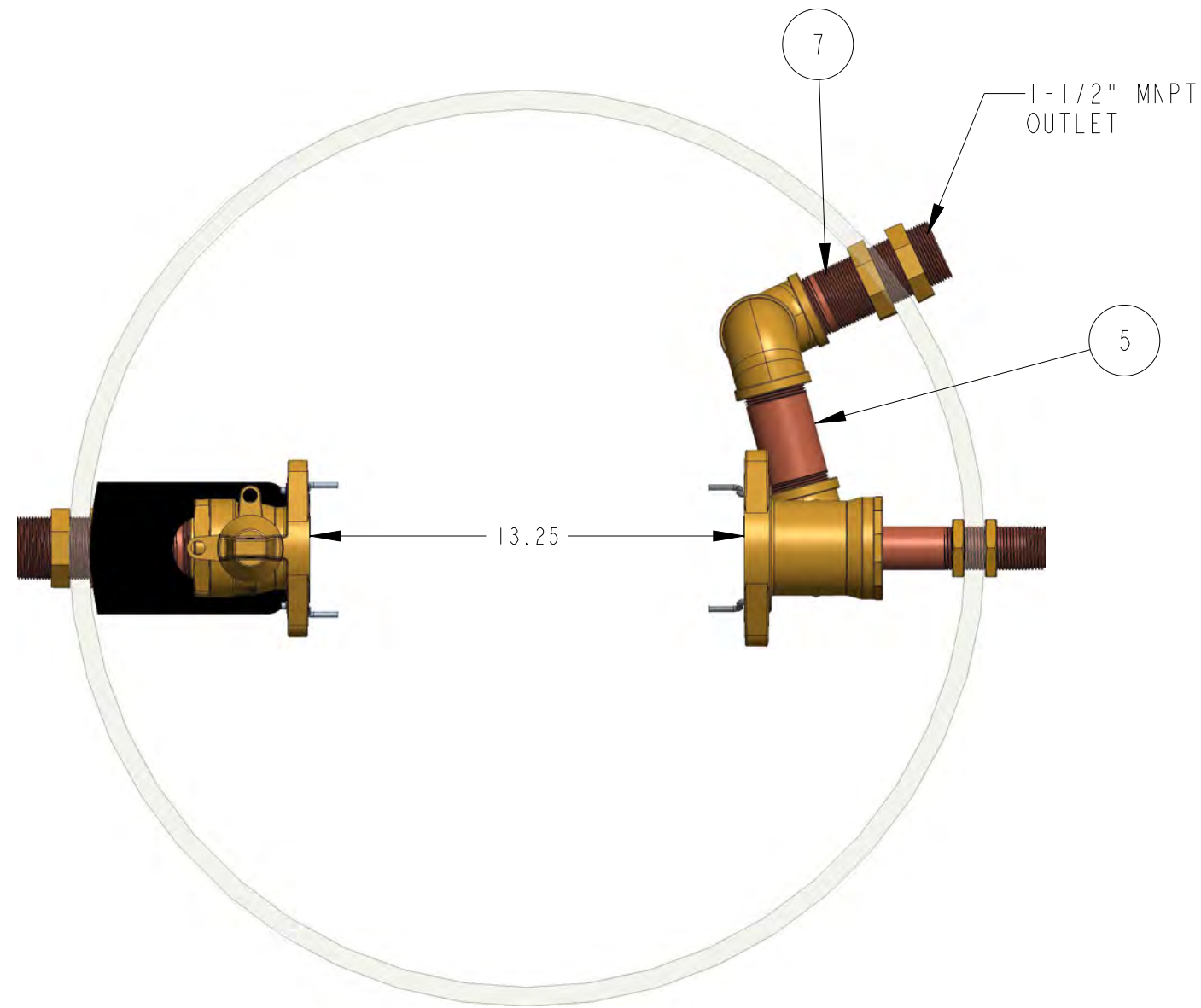

ITEM NO	PART NUMBER	QTY	DESCRIPTION
1	047141	1	1-1/2" CLOSED NIPPLE
2	547404	1	SUPPORT BRACKET
3	551236	1	1" RISER W/ 7" CENTERLINE BEND
4	551238	1	1-1/2" BRASS PIPE
5	551254	1	NIPPLE 1-1/2" X 4-1/2"
6	700005-2730	1	SHELL
7	700027	1	1-1/2" NIPPLE
8	700098-1	1	CAST IRON FRAME (PURCHASED SEPARATELY)
9	700499	1	1-1/2" THREADED PIPE
10	700512	1	1-1/2" NIPPLE
11	780113	1	18" DIA CAST IRON LID W/ RECESSED TR (SOLD SEPARATELY)
12	790010	2	1" HEX NUT
13	790038	4	1-1/2" HEX NUT
14	790327	1	27" INSULATION PAD (PURCHASED SEPARATELY)
15	094988E	3	1-1/2" 90 DEG ELBOW
16	330B20242N	1	1" INLINE BALL VALVE
17	500B242860IN	1	1-1/2" FULL PORT BALL VALVE
18	500H14244N	1	1-1/2" DUAL CHECK VALVE
19	790229E	1	1-1/2" X 1" TEE

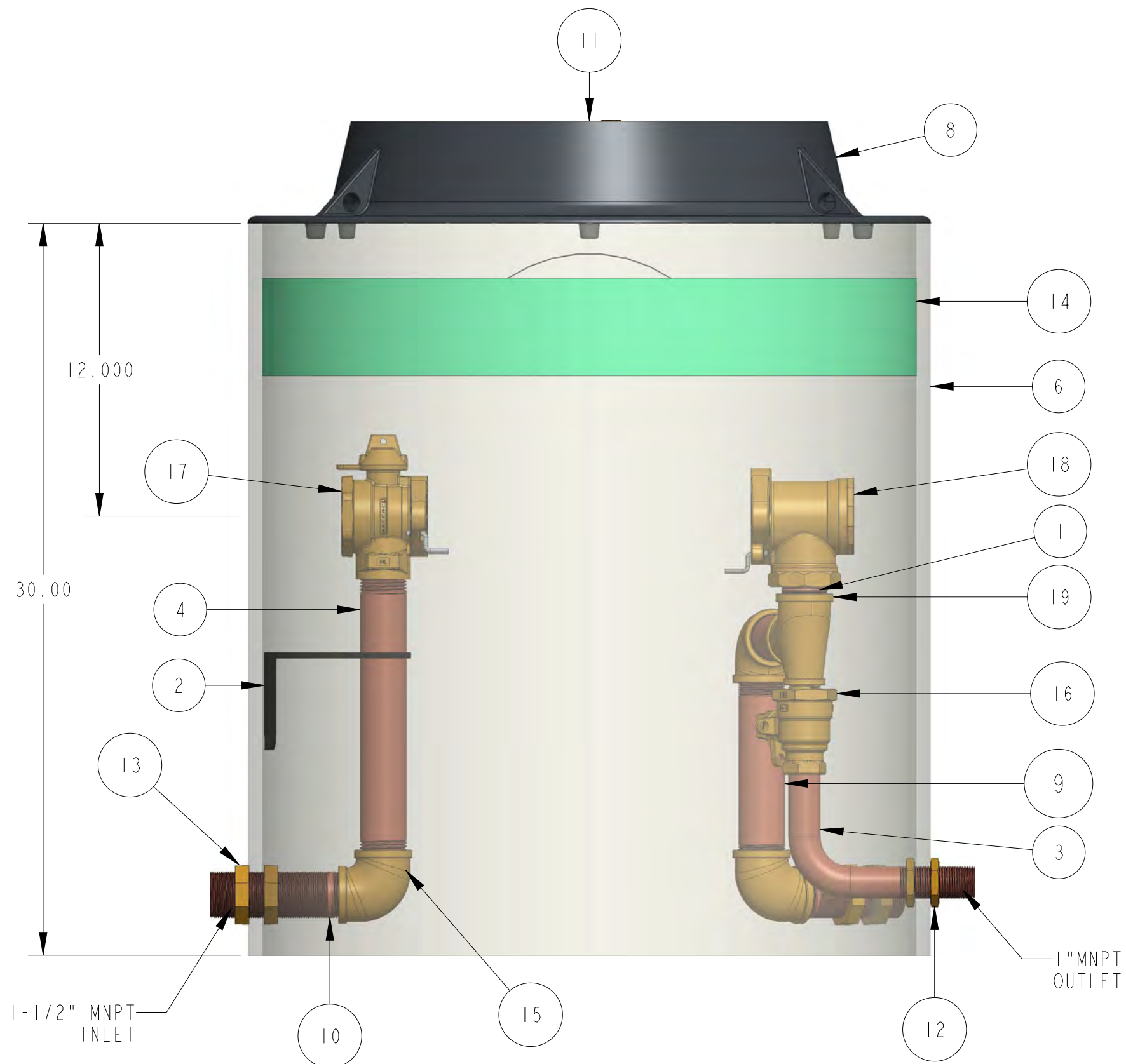

OPTION CODE: 000733

- * 12" CENTERLINE
- * FIRELINE WITH (1) 1-1/2" OUTLET AND (1) 1" OUTLET
- * INLINE BALL VALVES INSTALLED ON BOTH OUTLETS

DR. BY	BBF	12/14/20	UNLESS OTHERWISE NOTED	THIRD ANGLE PROJECTION	C.B. NO.
CHKR			BREAK CAST CORNER(S)---		
ENGR			BREAK MACH CORNER(S)---	PURCH.	FINISH
MGR			TOLERANCES	REF. NO.	PATT. NO.
MFG			UNLESS OTHERWISE NOTED	SCALE	
TOOL			LINEAR	ANGULAR	
FDRY			±	±	STR. NO.
MAT'L:					
MUELLER			DESCR. 1-1/2" VAULT SINGLE METER PIT 27" DIA X 30" DEPTH LOW LEAD BRASS		NUMBER 500VS2730FBB000733N