

ITEM NO	PART NUMBER	QTY	DESCRIPTION
1	199481	1	3/4" SQUARE HEAD PLUG
2	547743	1	36" INSULATION PAD (SOLD SEPERATELY)
3	548737	1	2" NIPPLE
4	700445	1	2" NIPPLE
5	780113	1	18" DIA CAST IRON LID W/ RECESSED TOUCH READ (OPTIONAL)
6	790043	2	2" HEX NUT
7	790244	1	36" x 36" SHELL
8	790438	1	36" EXTENSION RING W/ 18" OPENING (SOLD SEPERATELY)
9	548720E	1	2" X 2" X 3/4" FNPT TEE
10	550B24337N	1	2" INLINE BALL VALVE
11	550H10129MN	1	2" MALE METER FLANGE
12	550H10887-----N	1	2" METER JUMPER
13	HG-15177E	2	2" UNION

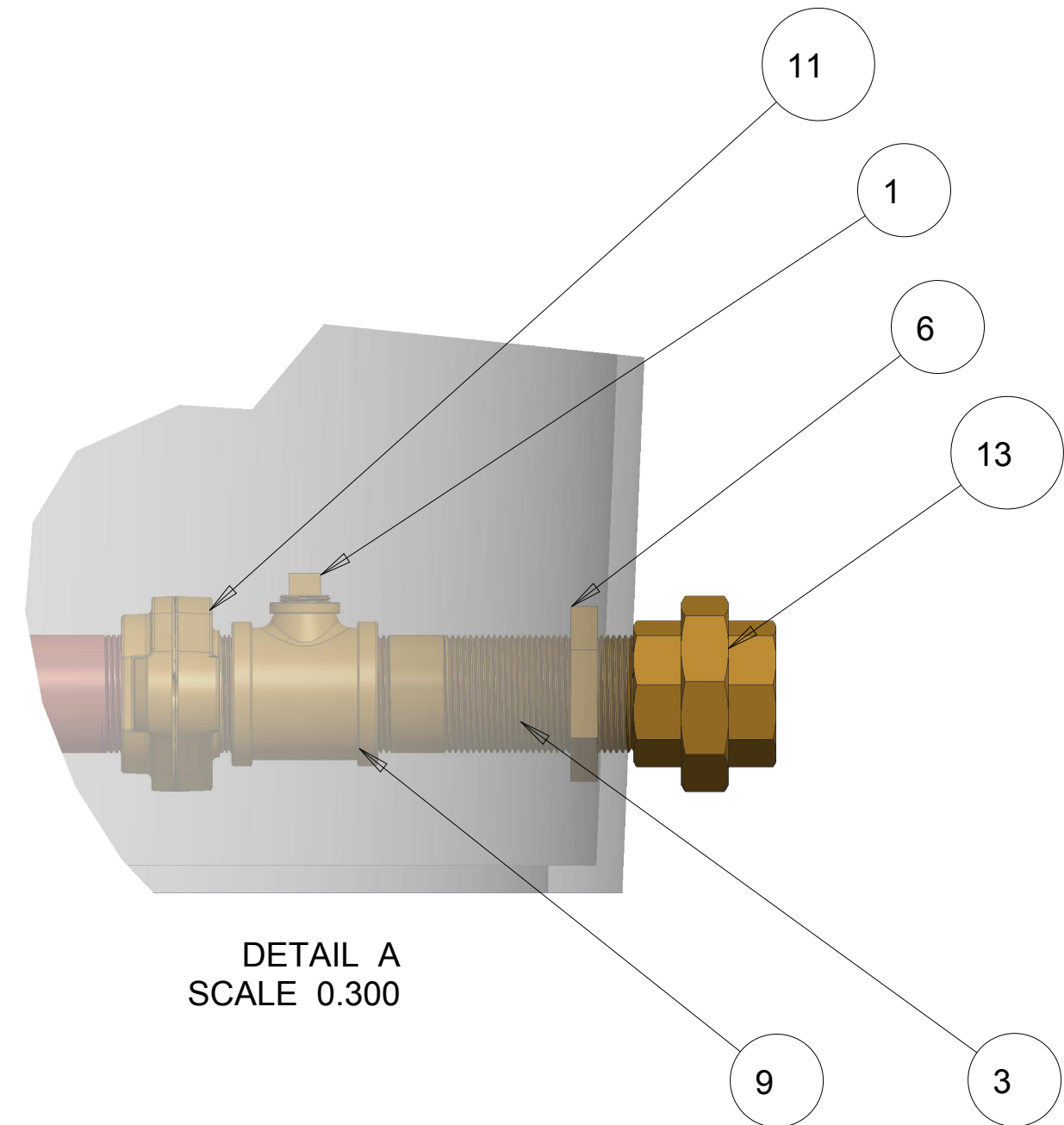
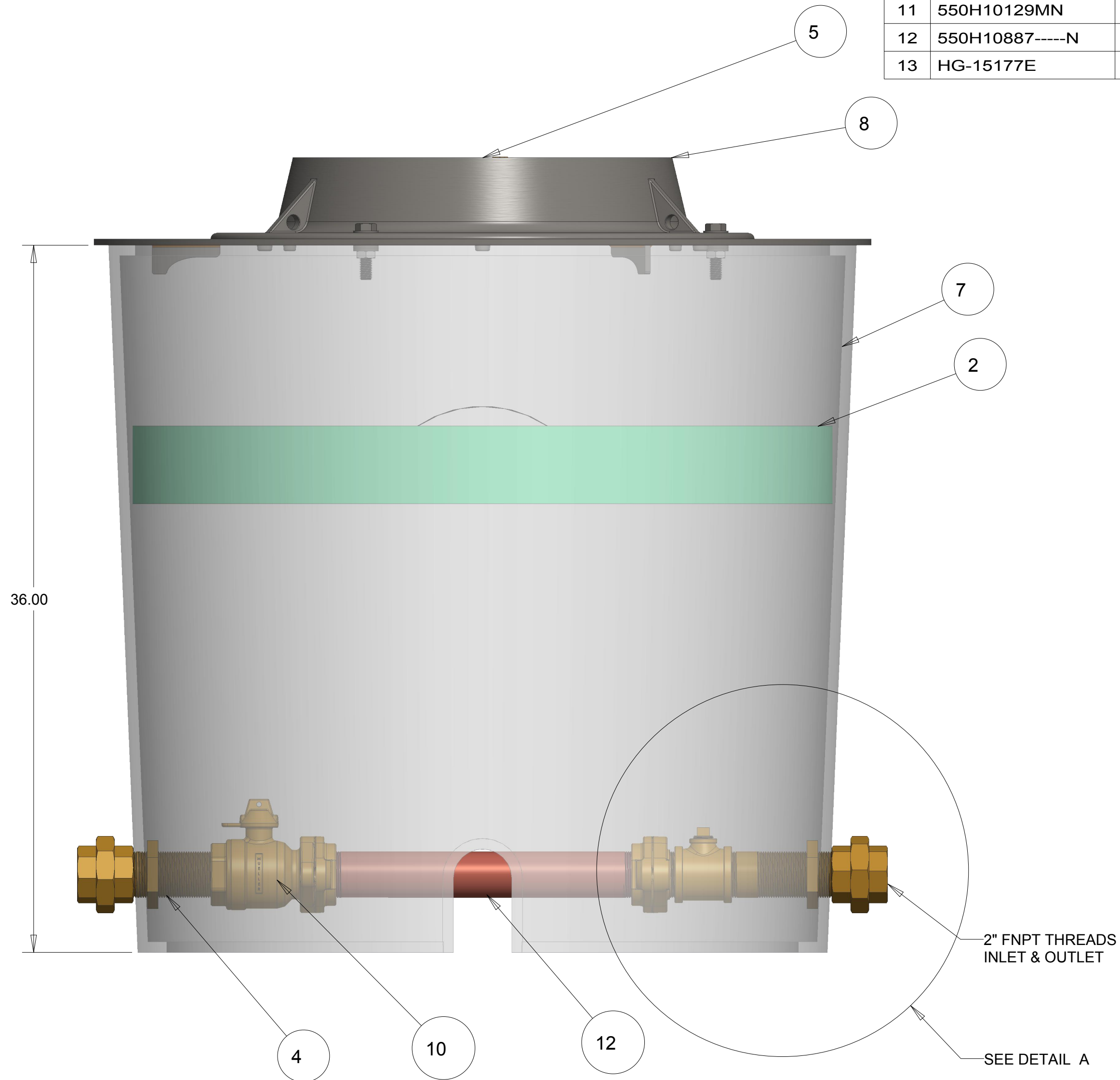

OPTION CODE: 000666
 *TEE INSTALLED AFTER METER FLANGE
 FOR A 3/4" SAMPLE PORT
 *INSTALL 3/4" PLUG INTO TEE

DR. BY	BBF	10/12/17	UNLESS OTHERWISE NOTED		THIRD ANGLE PROJECTION		C.B. NO.	
CHKR			BREAK CAST CORNER(S)---					
ENGR			BREAK MACH CORNER(S)---		PURCH.	FINISH	PATT. NO.	
MGR			TOLERANCES UNLESS OTHERWISE NOTED		REF. NO.	SCALE		
MFG			LINEAR	ANGULAR	STK. NO.			
TOOL			±	±				
FDRY			MATERIAL:					
			Mueller Co.				NUMBER	
			DESCR. 2" INLINE SINGLE 36" DIA X 36" DEPTH LOW LEAD BRASS				550IS3636FAB000666N	