

550VB3636FVBN

ITEM NO	PART NUMBER	QTY	DESCRIPTION
1	047141	1	1-1/2" CLOSED NIPPLE
2	548475	1	2" THREADED PIPE
3	548555	2	STAINLESS STEEL SUPPORT BRACKET
4	548556	2	BULKHEAD NIPPLE
5	548988	1	2" THREADED PIPE
6	700047	1	COPPER TUBING
7	780113	1	18" DIA CAST IRON LID W/ RECESSED TR (PURCHASED SEPARATELY)
8	790043	4	2" HEX NUT
9	790244	1	36" x 36" SHELL
10	790438	1	36" EXTENSION RING W/ 18" OPENING (SOLD SEPERATELY)
11	500H1517201N	1	1-1/2" ORISEAL VALVE
12	500H15428N	1	1-1/2" 110 COMP X MIP TAILPIECE
13	550B2428601N	1	2" FULL PORT BALL VALVE
14	550H14660AN	1	2" ASSE APPROVED VERTICAL CHECK VALVE
15	790051E	2	2" X 2" X 1-1/2" TEE

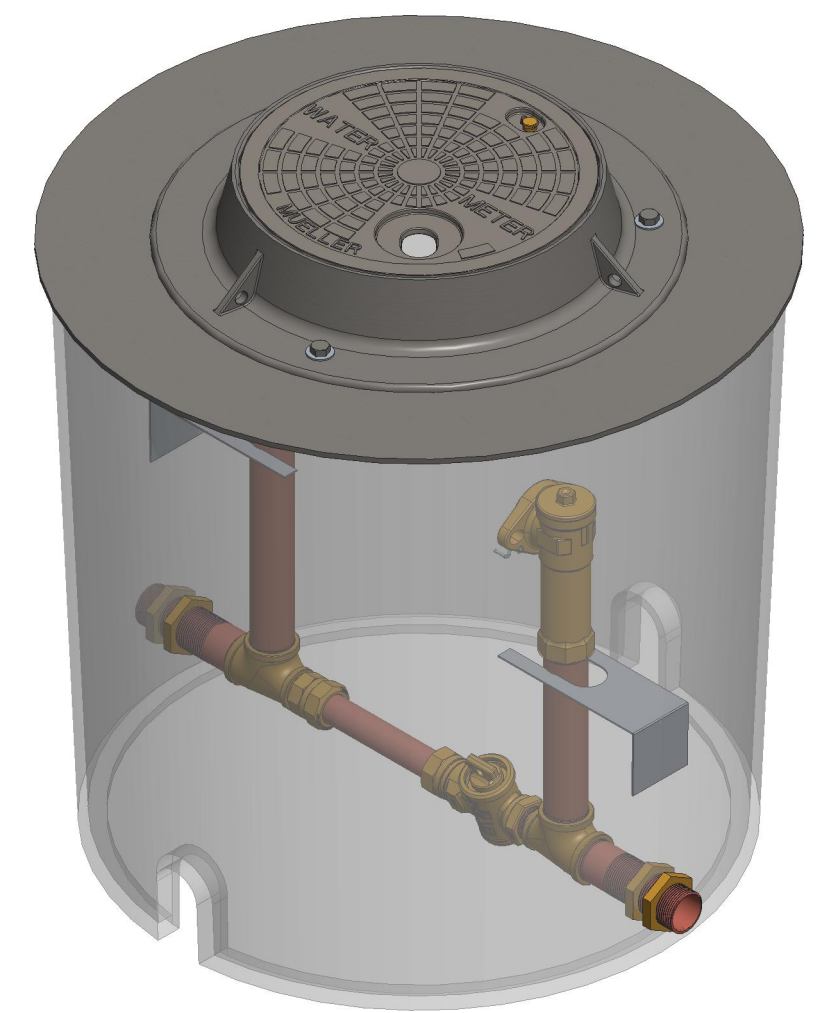
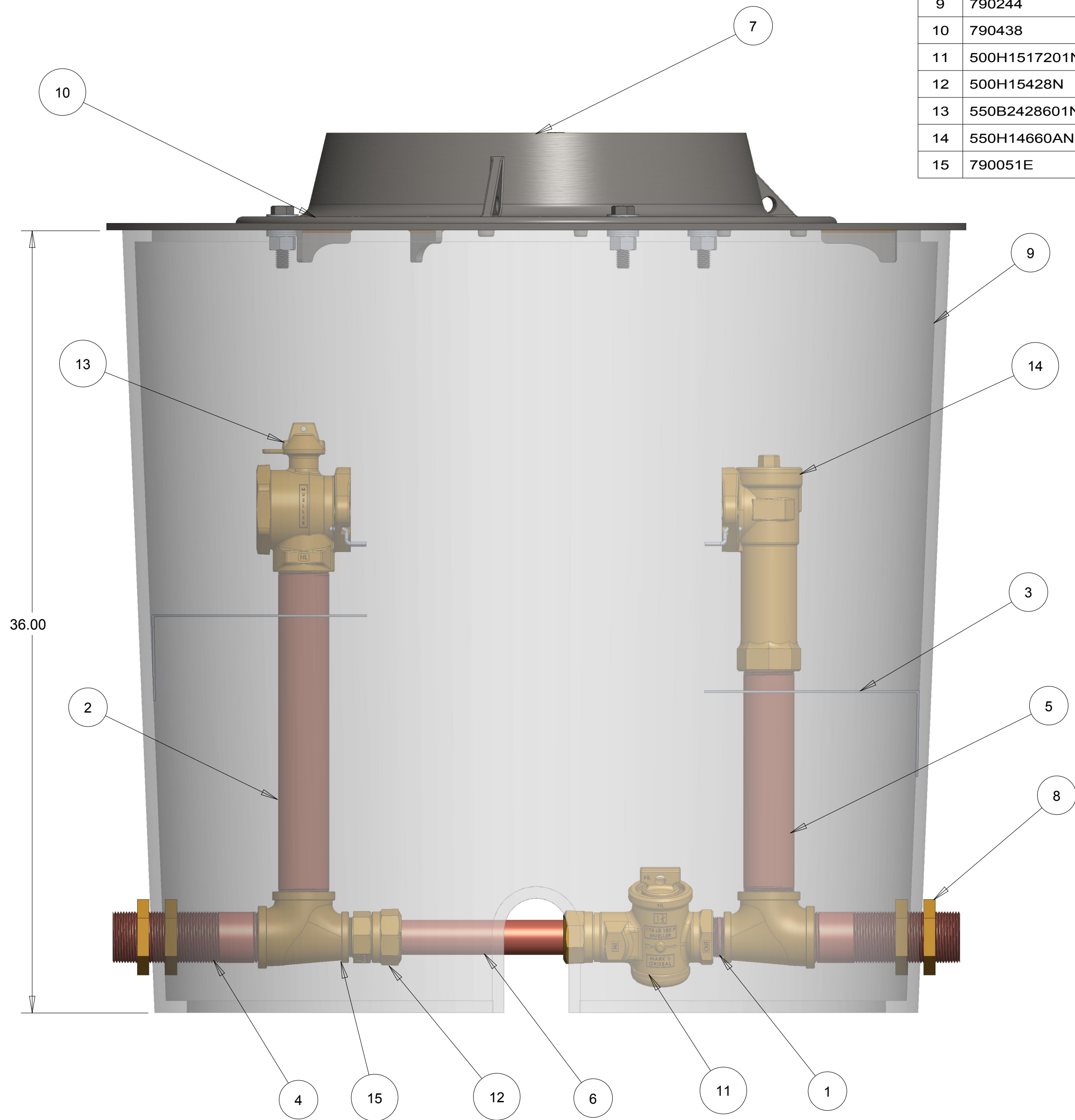

DR. BY	BBF	4/25/18	UNLESS OTHERWISE NOTED		THIRD ANGLE PROJECTION		C.B. NO.
CHKR			BREAK CAST CORNER(S)---				
ENGR			BREAK MACH CORNER(S)---		PURCH.	FINISH	PATT. NO.
MGR			TOLERANCES UNLESS OTHERWISE NOTED		REF. NO.	SCALE	
MFG			LINEAR	ANGULAR	STK. NO.		
TOOL			±	±			
FDRY			MATERIAL:				
					DESCR.	2" VAULT BY-PASS 36"DIA X 36" DEPTH LOW LEAD BRASS	NUMBER 550VB3636FVBN