

550VB3636LLBN

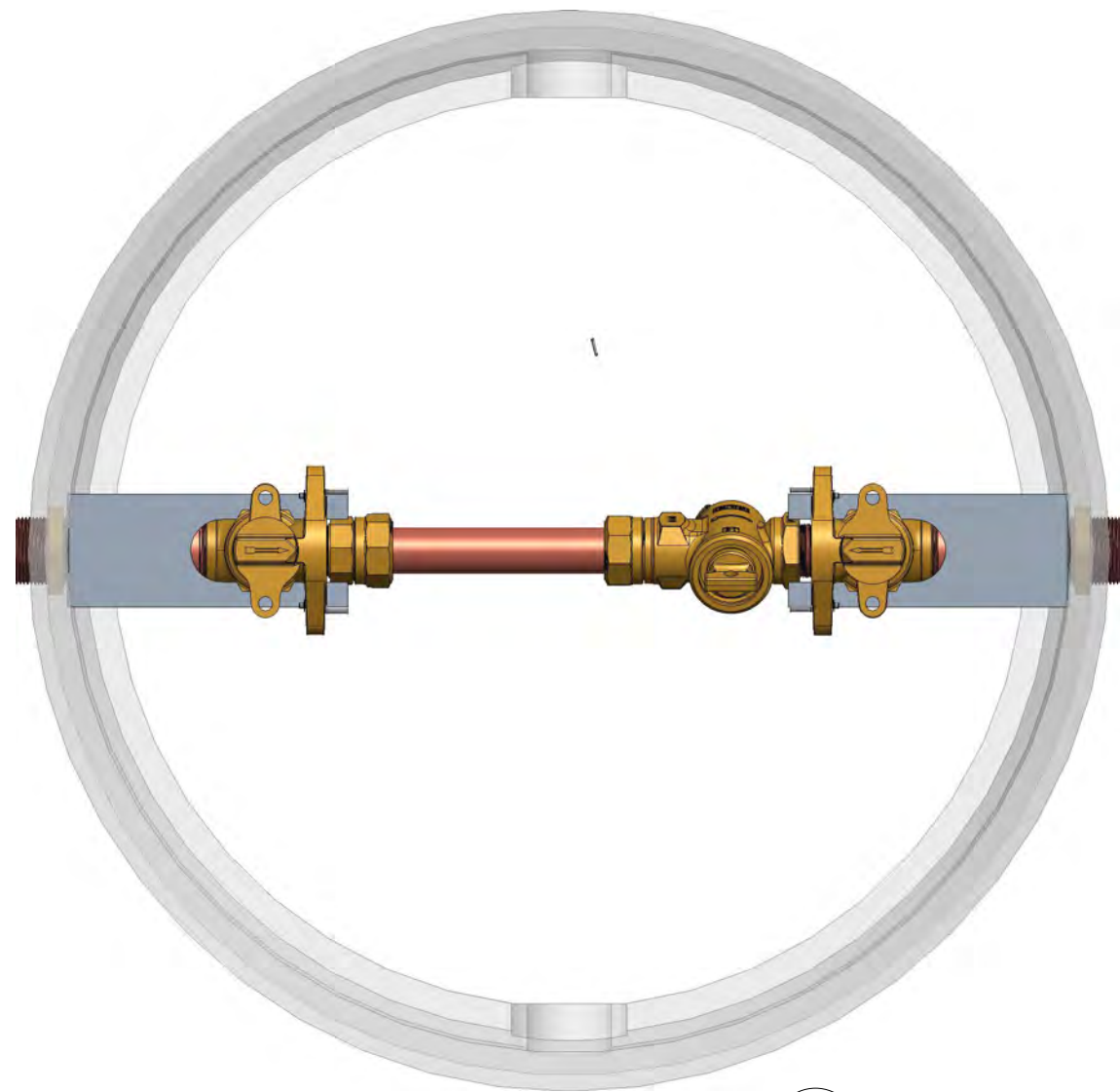

ITEM NO	PART NUMBER	QTY	DESCRIPTION
1	047141	1	1-1/2" CLOSED NIPPLE
2	547049	2	2" THREADED PIPE
3	548555	2	STAINLESS STEEL SUPPORT BRACKET
4	548556	2	BULKHEAD NIPPLE
5	700047	1	COPPER TUBING
6	780113	1	18" DIA CAST IRON LID W/ RECESSED TR (SOLD SEPARATELY)
7	790043	4	2" HEX NUT
8	790244	1	36" x 36" SHELL
9	790438	1	36" EXTENSION RING W/ 18" OPENING (SOLD SEPERATELY)
10	500H1517201N	1	1-1/2" ORISEAL VALVE
11	500H15428N	1	1-1/2" 110 COMP X MIP TAILPIECE
12	550H1428601N	2	2" ANGLE METER STOP
13	790051E	2	2" X 2" X 1-1/2" TEE

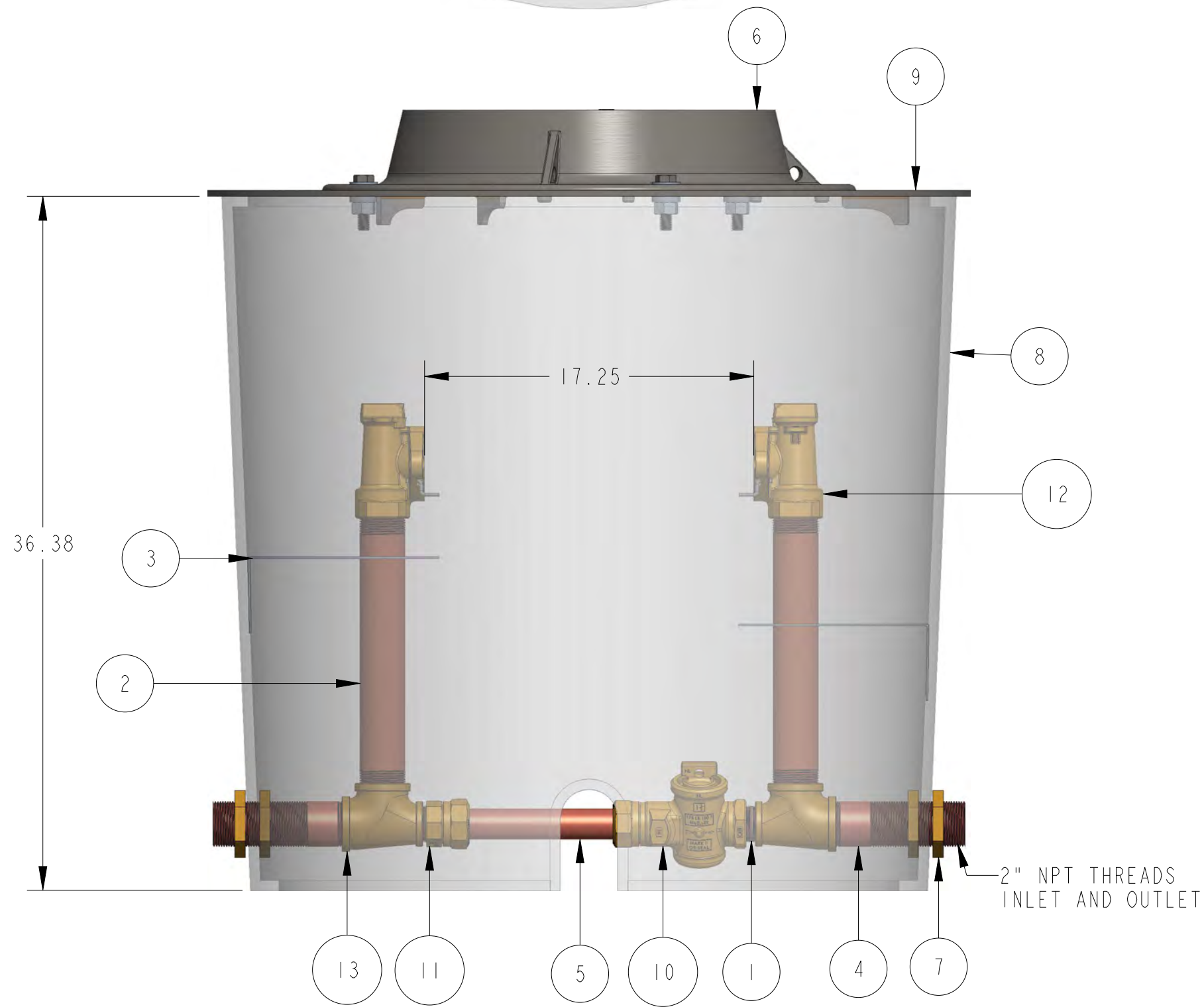

(B)
 CHANGED LAY LENGTH FROM
 15-1/4" TO 17-1/4"
 1/12/22
 AOD

DR. BY	AOD	1/06/22	UNLESS OTHERWISE NOTED	THIRD ANGLE PROJECTION	C.B. NO.
CHKR			BREAK CAST CORNER(S)---		
ENGR			BREAK MACH CORNER(S)---	PURCH.	FINISH
MGR			TOLERANCES	REF. NO.	SCALE
MFG			UNLESS OTHERWISE NOTED	STR. NO.	
TOOL			LINEAR	ANGULAR	
FDRY			±	±	
MAT'L:					
MUELLER			DESCR. 2" VAULT BYPASS METER PIT 36" DIA X 36" DEPTH LOW LEAD BRASS		NUMBER 550VB3636LLBN