

AWWA C515 18" - 36" A2361 RESILIENT WEDGE GATE VALVES - W/ROTORK SPUR GEARING - W/ SIDE BY-PASS & OPT. E302

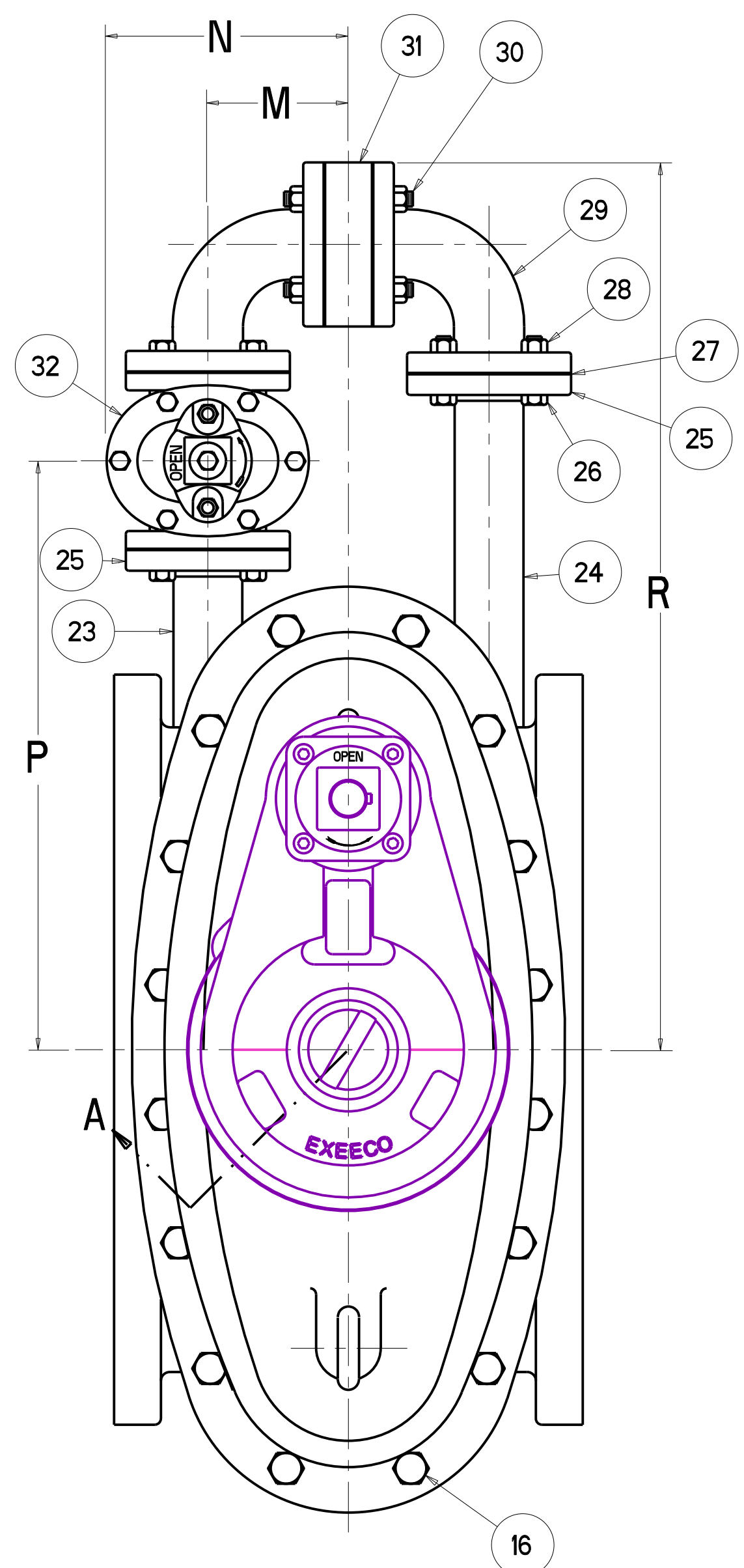

*** BY-PASS VALVES
 FOR 18" & 20" SIZES - 2" - RWGV - FLANGE ENDS
 FOR 24" SIZE - 2.5" - RWGV - FLANGE ENDS
 FOR 30" & 36" SIZE - 3" - RWGV - FLANGE ENDS
 BY-PASS VALVES EQUIPPED WITH 2" SQUARE WRENCH NUT
 OR 6" DIA HANDWHEEL OPEN LEFT OR RIGHT AS REQUIRED
 CONFORM TO AWWA C509

2" SQUARE WRENCH NUT OR HANDWHEEL
 OPEN LEFT OR RIGHT
 AS REQUIRED

G - NO. & SIZE
 OF BOLT HOLES
 EQUALLY SPACED
 ON H - DIA B.C.
 STRADDLE

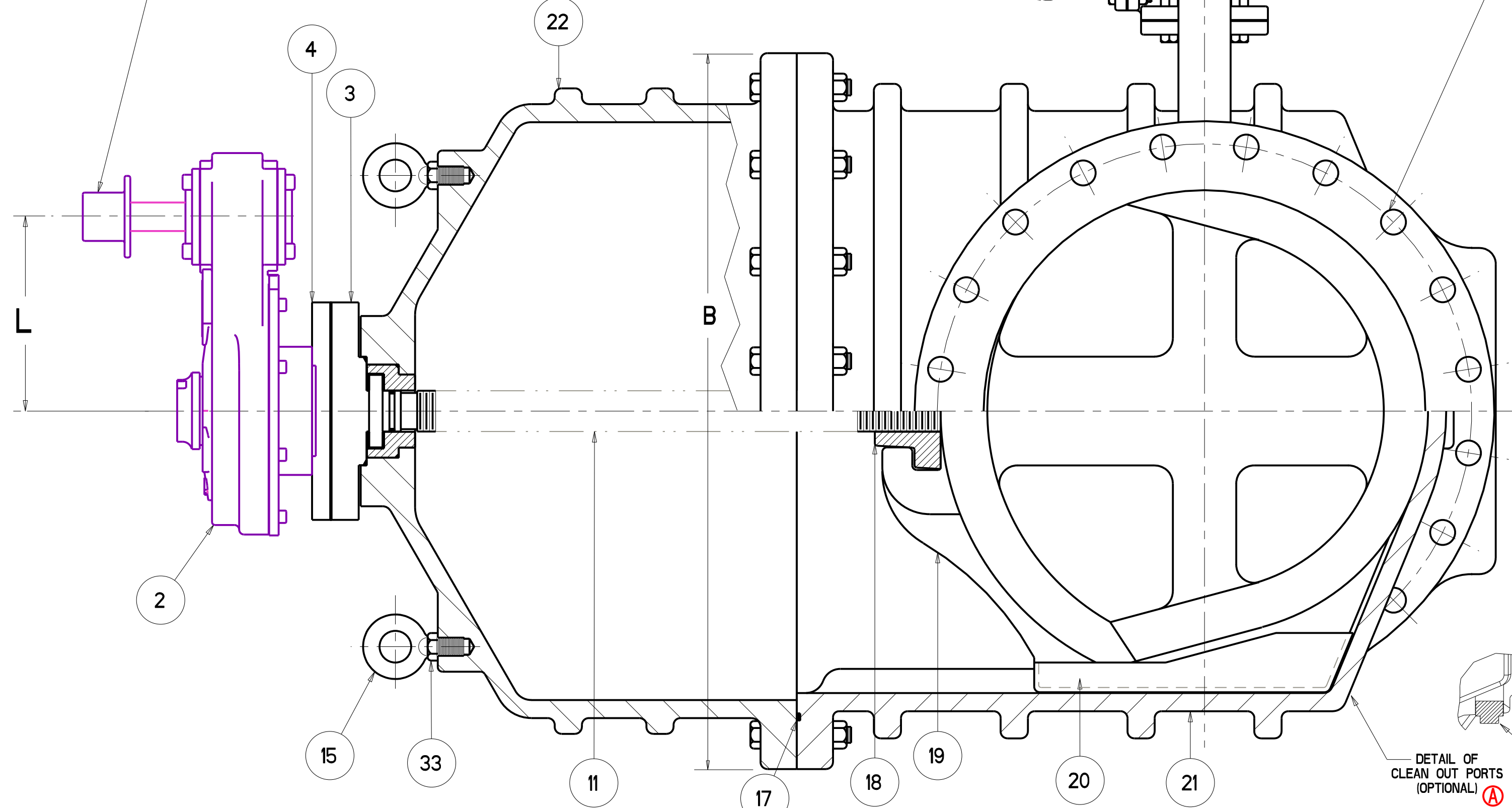

PARTS LIST					
ITEM	DESCRIPTION	REQ'D	MATERIAL	ASTM	NOTES
1	WRENCH NUT	1	CAST IRON (SEE NOTE 4)	A126	CLASS B
2	ROTORK SPUR GEAR IS-5	1	CAST IRON	A48	35B/40B
3	STUFFING BOX	1	HOT ROLLED STEEL	A36	
4	ADAPTER PLATE	1	HOT ROLLED STEEL	A36	
5	SOCKET HEAD SCREW	4	316 STAINLESS STEEL		SEE NOTE 2
6	GASKET	1	RUBBER	D2000	R51
7	O-RING	1	RUBBER	D2000	EPDM
8	SOCKET HEAD BOLT & NUT	4	316 STAINLESS STEEL		SEE NOTE 2
9	O-RING	1	RUBBER	D2000	EPDM
10	O-RING	1	RUBBER	D2000	EPDM
11	STEM	1	BRONZE		SEE NOTE 3
12	O-RING	3	RUBBER	D2000	EPDM
13	ANTI-FRICTION WASHER	2	BRASS		
14	BONNET BUSHING	1	BRONZE	B62	ALLOY C83600
15	EYE BOLT	2	STEEL		GALVANIZED
16	HEX BOLT & NUT	"J"	316 STAINLESS STEEL		SEE NOTE 2
17	O-RING	1	RUBBER	D2000	EPDM
18	DISC NUT	1	BRONZE	B62	ALLOY C83600
19	DISC ENCAPSULATED	1			SEE NOTE 1
20	GUIDE CAP	2	CELCON		M90
21	BODY - FLG ENDS	1	DUCTILE IRON	A536	GR 65-45-12
22	BONNET	1	DUCTILE IRON	A536	GR 65-45-12
23	SHORT NIPPLE	1	STEEL PIPE		
24	LONG NIPPLE	1	STEEL PIPE		
25	PIPE FLANGE	2	STEEL		
26	HEX BOLT	12	316 STAINLESS STEEL		SEE NOTE 2
27	PIPE GASKET	5	REINFORCED NEOPRENE	D2000	
28	HEX NUT	20	316 STAINLESS STEEL		SEE NOTE 2
29	PIPE ELBOW	2	CAST STEEL		
30	STUD	4	316 STAINLESS STEEL		SEE NOTE 2
31	SPACER	1	STEEL		
32	BY-PASS VALVE	1	***		
33	HEX NUT	2	STEEL	A136	
34	PIPE PLUG	2	SUPPLIED WHEN TAPPED		
35	BODY - FLG X MJ ENDS	1	DUCTILE IRON	A536	GR 65-45-12
36	BODY - MJ X MJ ENDS	1	DUCTILE IRON	A536	GR 65-45-12

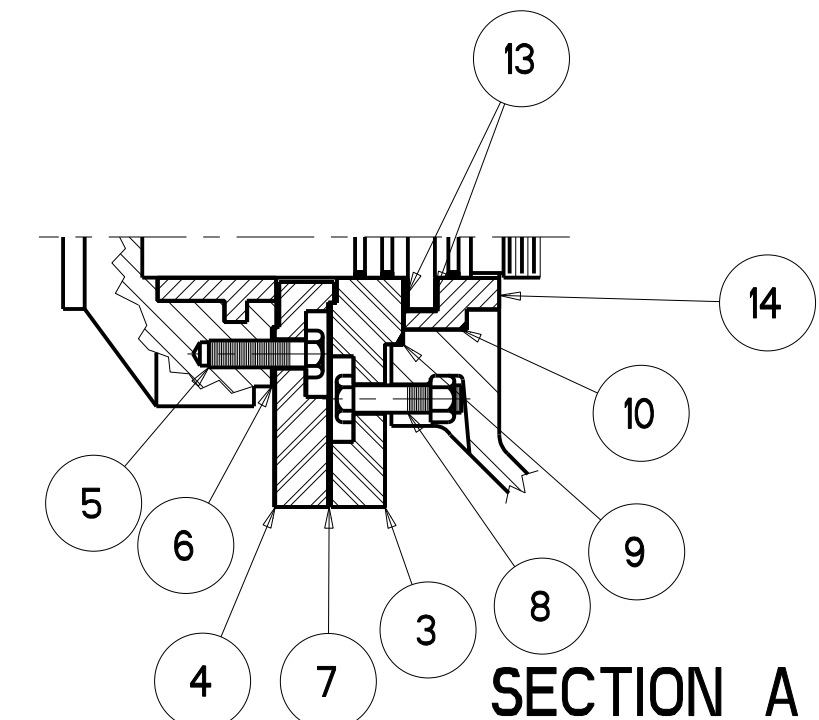

SECTION A

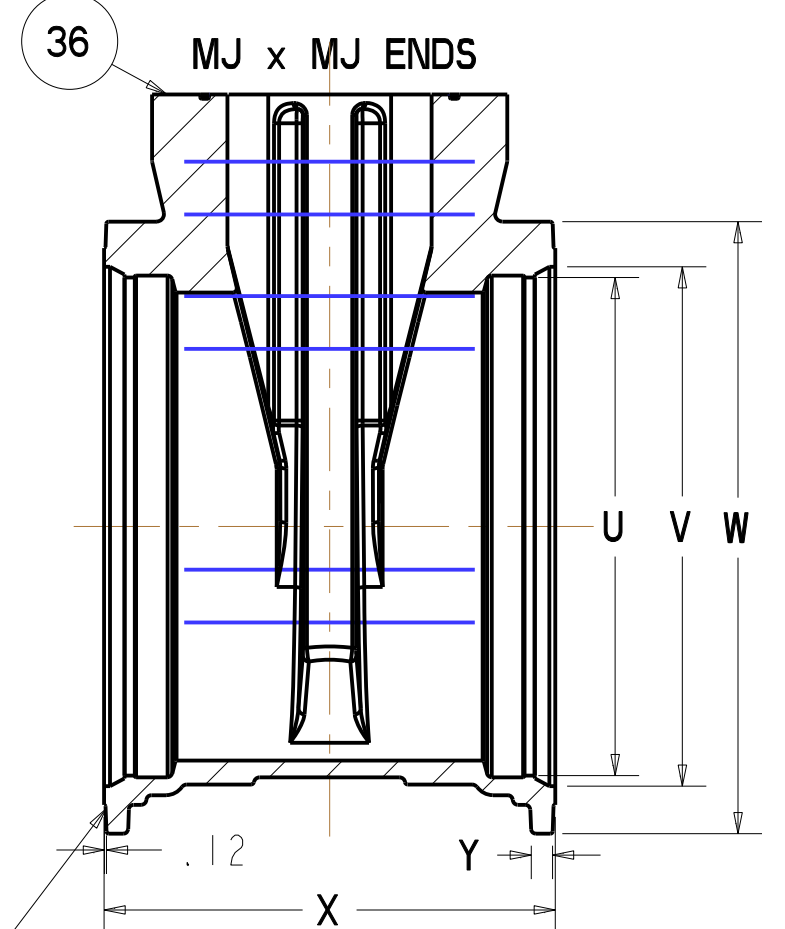
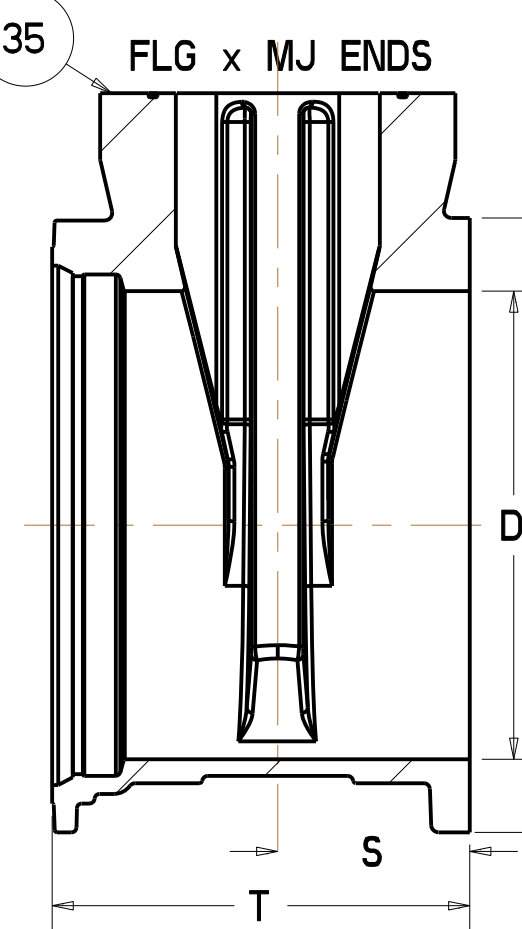

MECH. JOINT ENDS:
 "AA" - NO. & SIZE HOLES
 AND OR SLOTS
 EQUALLY SPACED
 ON "BB" B.C.

NOTES:
 1) RUBBER ENCAPSULATED DUCTILE IRON DISC
 RUBBER - EPDM ASTM D2000
 DUCTILE IRON ASTM A536 GRADE 65-45-12
 2) BOLTS ARE - 316 STAINLESS STEEL ASTM A193
 NUTS ARE - 316 STAINLESS STEEL ASTM A194
 3) 18", 20", & 24" VALVES - BRONZE ASTM 584 ALLOY C86400 OR C86500
 30" & 36" VALVES - BRONZE ASTM B694 ALLOY C86200 OR C86700
 4) MANUFACTURER'S OPTION TO UPGRADE MATERIAL TO
 DUCTILE IRON A536 GRADE 65-45-12

VALVE SIZE	A	B	C	D	E	F	G	H	J	K	L	M	N	P	Q	R	S	T	U	V	W	X	Y	AA	BB	URNS TO OPEN 18"-36"	HANDWHEEL DIAMETER
18	49.64	30.50	25.00	18.38	17.00	1.69	16 - 1.25	22.75	12	10.24	8.00	5.00	8.50	21.50	9.88	32.50	8.50	19.00	19.64	20.74	24.88	21.00	1.06	12 - .88	23.25	234	18.00
20	52.75	33.75	27.50	20.38	18.00	1.78	20 - 1.25	25.00	12	10.24	8.00	5.00	8.50	22.50	9.88	33.50	9.00	19.75	21.74	22.84	27.25	21.50	1.60	14 - .88	25.50	258	18.00
24	59.15	39.50	32.00	24.38	20.00	2.00	20 - 1.38	29.50	16	10.24	8.00	6.00	10.31	25.06	12.38	37.31	10.00	21.75	25.94	27.05	31.88	23.50	1.12	16 - .88	30.00	308	18.00
30	70.83	48.00	38.75	30.38	26.00	2.12	28 - 1.38	36.00	20	10.24	8.00	7.08	11.67	27.70	12.38	43.20	13.00	29.75	32.18	33.47	39.53	33.50	1.25	20 - 1.125	36.88	381	18.00
36	83.14	56.50	46.00	36.38	30.00	2.37	32 - 1.63	42.75	24	10.24	8.00	8.75	13.40	31.75	12.38	47.25	15.00	33.75	38.48	39.77	46.41	37.50	1.45	24 - 1.125	43.75	455	24.00

SR BY: CAP	03/10/05	UNLESS OTHERWISE NOTED	THIRD ANGLE PROJECTION	C.D. NO.
CHNG: PSG	03/11/05	BREAK CAST CORNERS!		PART. NO.
ENGR: RWV	03/11/05	BREAK MACH CORNERS!		
MFG:		TOLERANCES	NO	ASSY
FIN:		UNLESS OTHERWISE NOTED	REF. NO.	SCALE
TOOL:		L INEAR	ANGULAR	NONE
FDRT:		±	±	STR. NO.

Mueller Co. NOTED
 AWWA C515 18"-36" A2361 RWGV'S
 W /ROTORK SPUR GEAR & OPT. E302
 NUMBER 6750-E302

APPROVED
 By Nicholas Franklin at 3:19 pm, Aug 18, 2009