

6762-316 14IN - 16IN RESILIENT WEDGE GATE VALVES - OS&Y

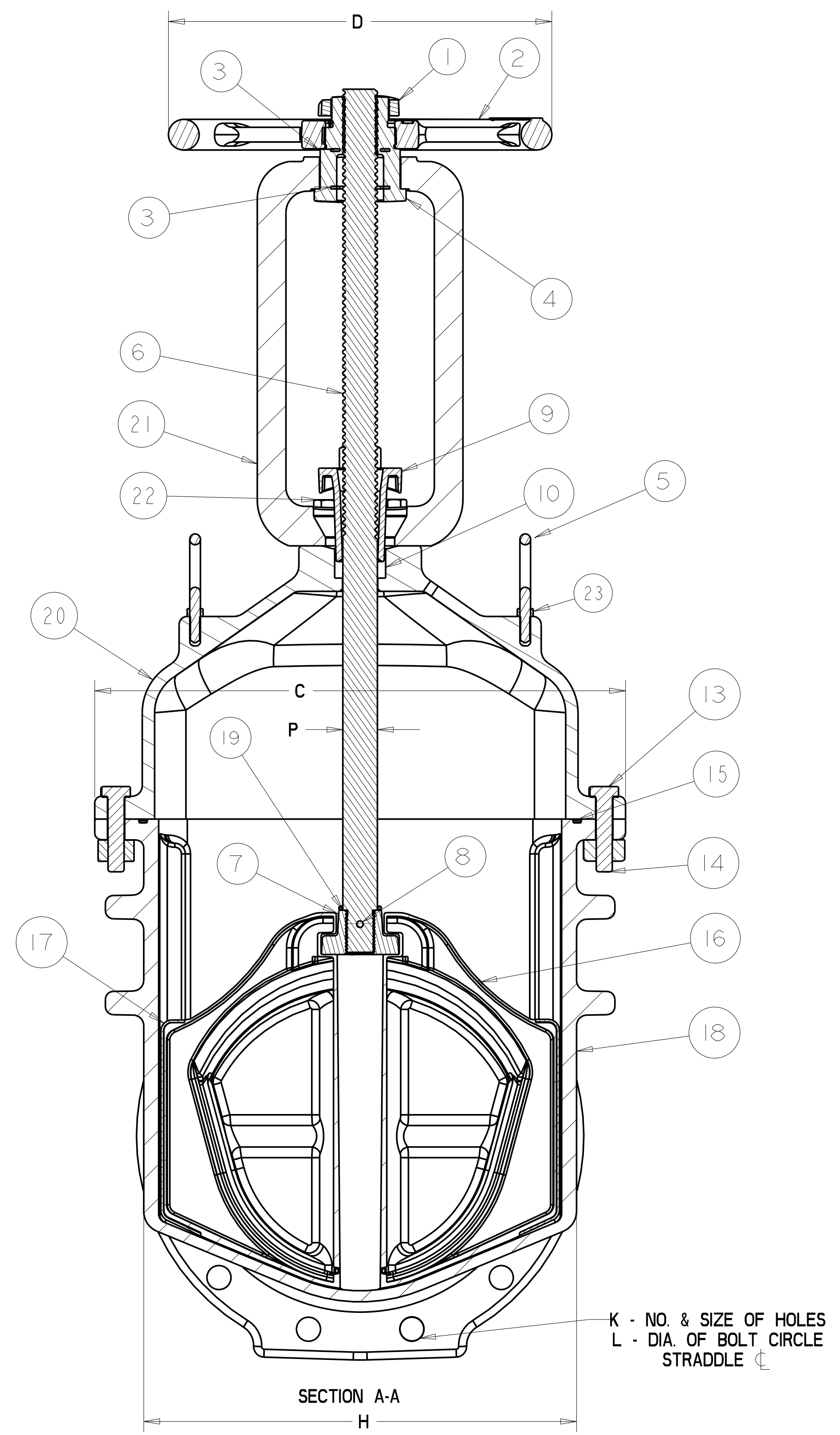

A - CLOSED
AA - OPEN

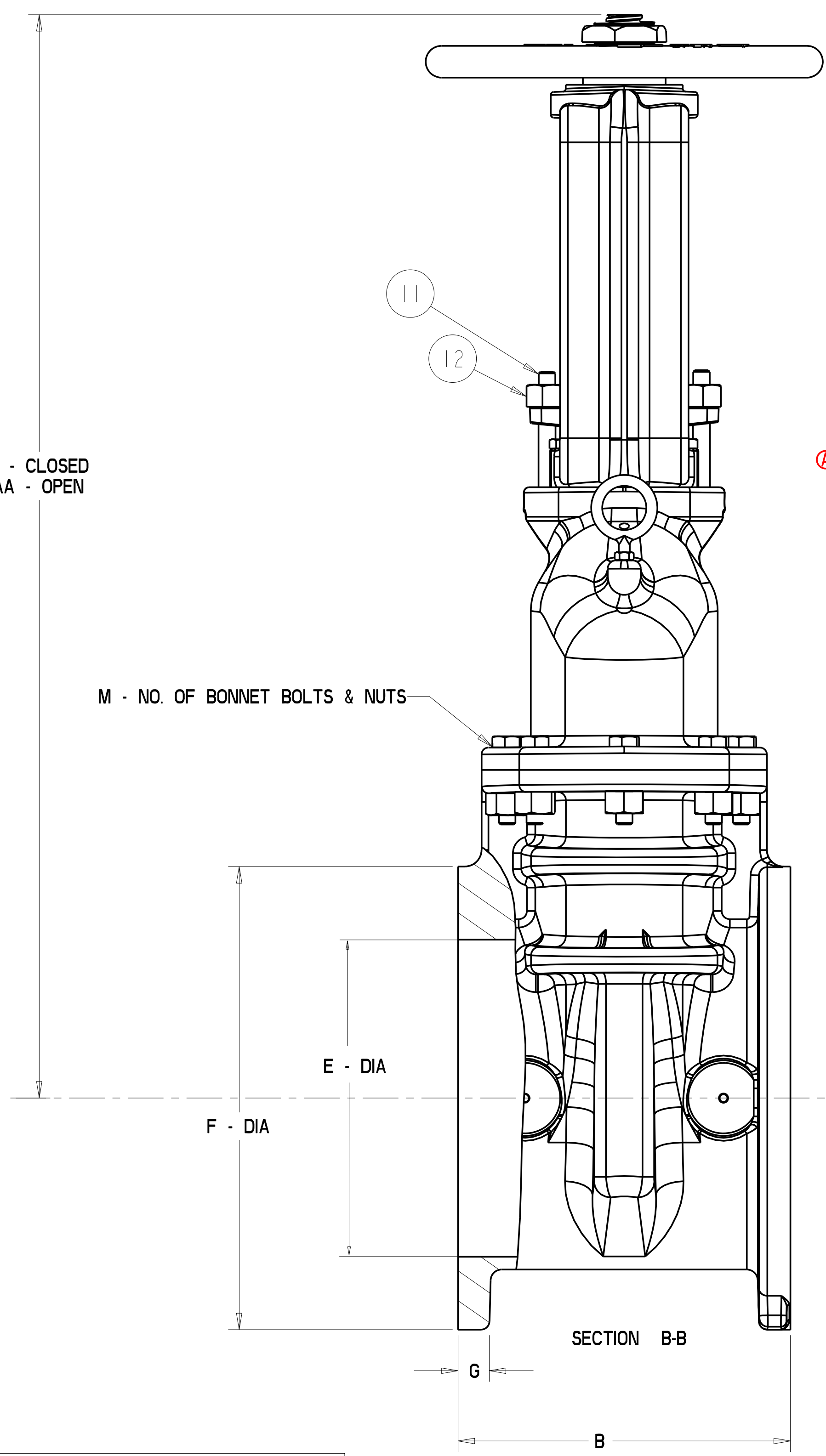

M - NO. OF BONNET BOLTS & NUTS

PART LIST						
ITEM	DESCRIPTION	RED'D	MATERIAL	ASTM	REMARKS	NOTES
1	CAP NUT	1	BRONZE	B62	ALLOY C83600	
2	HANDWHEEL (SEE NOTE 1)	1	CAST IRON	A126	CLASS B	
3	WASHER	2	BRONZE			
4	BUSH NUT	1	BRONZE	B584	ALLOY C84400	
5	EYEBOLT	2	FORGED STEEL			
6	STEM	1	BRONZE	B138	ALLOY C67600	
7	DISC NUT	1	BRONZE	B62	ALLOY C83600	
8	PIN	1	STAINLESS STEEL		TYPE 304	
9	GLAND FLANGE	1	DUCTILE IRON	A536	GRADE 65-45-12	
10	STEM PACKING	"N"	LUBE FLAX		FED HH-P-106c	
11	GLAND BOLT	2	STEEL - ZINC PLATE	A633	GRADE 2	
12	GLAND NUT	2	SILICON BRONZE	B98	ALLOY B-12	
13	BONNET BOLT	"F"	316 STAINLESS STEEL	A193	GRADE B8M	
14	BONNET NUT	"F"	316 STAINLESS STEEL	A194	GRADE 8M	
15	O-RING	1	RUBBER	D2000	R34	
16	DISC RUBBER DISC CASTING	1	RUBBER DUCTILE IRON	D2000 A536	SBR GRADE 65-45-12	
17	GUIDE CAP	2	CELCON		M90	
18	BODY	1	DUCTILE IRON	A536	65-45-12	
19	O-RING	1	RUBBER	D2000	R34	
20	BONNET	1	DUCTILE IRON	A536	GRADE 65-45-12	
21	YOKE (SEE NOTE 1)	1	CAST IRON	A126	CLASS B	
22	CAP SCREW	4	316 STAINLESS STEEL	A193	GRADE B8M	
23	HEX NUT	2	STEEL	A563	GRADE B ZINC - PLATE	

NOTES
 1) MANUFACTURER'S OPTION TO UPGRADE MATERIAL TO DUCTILE IRON A536 GRADE 65-45-12

VALVE SIZE	DIMENSIONS FOR RWGV OS&Y - INCHES														TURNS TO OPEN
	A	AA	B	C	D	E	F	G	H	K	L	M	N	P	
14	49.13	64.09	15.06	24.92	18.00	14.38	21.00	1.42	20.32	12 - 1.125	18.750	10	4	1.63	43.5
16	54.63	71.19	16.06	26.58	18.00	16.00	23.50	1.59	21.64	16 - 1.125	21.250	12	4	1.75	49

APPROVED
 By MATT BARDELLI at 11:19 am, Jan 30, 2008

SR BY: CAP 03/22/07	UNLESS OTHERWISE NOTED	THIRD ANGLE PROJECTION	C.D. NO.
CHD: CGH 03/22/07	BREAK CAST CORNERS!		PART. NO.
ENR: JWB 03/22/07	BREAK MACH CORNERS!		
MFR:	TOLERANCES	PURCH. NO.	FINISH
MFG:	UNLESS OTHERWISE NOTED	REF. NO.	ASSY
TOOL:	L INEAR	STR. NO.	NONE
FBY:	ANGULAR		
MATERIAL NOTED			
DESCR. 14IN-16IN RWGV OS&Y WITH 316 STAINLESS STEEL		NUMBER 6762-316	