

ITEM NO	PART NUMBER	QTY	DESCRIPTION
1	282621	2	RISER SUB ASSEMBLY
2	509704	2	1 1/2" RISER TEE
3	282970E	1	1" TIE BAR SUB ASSEMBLY
4	330H15428N	1	1" MIP X 1" CTS COMPRESSION TAILPIECE
5	500B242860IN	1	1-1/2" FULL PORT BALL VALVE
6	500H14204N	1	1-1/2" METER COUPLING

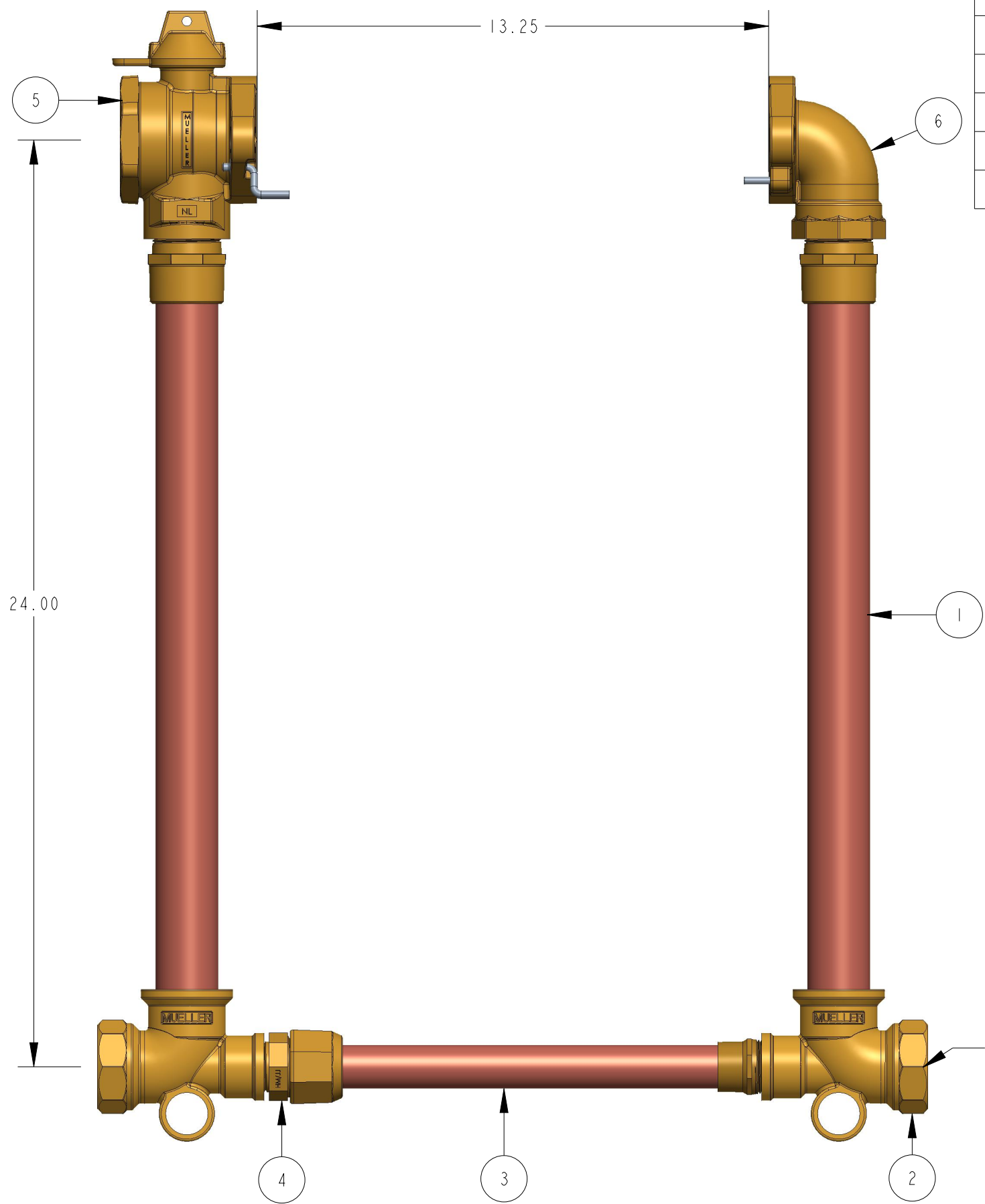

721B2422-----N

DR. BY	AOD	6/11/21	UNLESS OTHERWISE NOTED	THIRD ANGLE PROJECTION	C.B. NO.
CHKR			BREAK CAST CORNER(S)---		
ENGR			BREAK MACH CORNER(S)---	PURCH.	PATT. NO.
MGR			TOLERANCES	FINISH	
MFG			UNLESS OTHERWISE NOTED	REF. NO.	SCALE
TOOL			LINEAR	±	NONE
FDRY			ANGULAR	±	
MAT'L:				STK. NO.	
<b>Mueller Co.</b>		DESCR: 1 1/2" COPPER METER SETTER 24" RISER HEIGHT LOW LEAD BRASS	NUMBER	721B2422-----N	