

14" - 36" RESILIENT WEDGE GATE VALVES - W/SPUR GEARING W/316SS FASTENERS

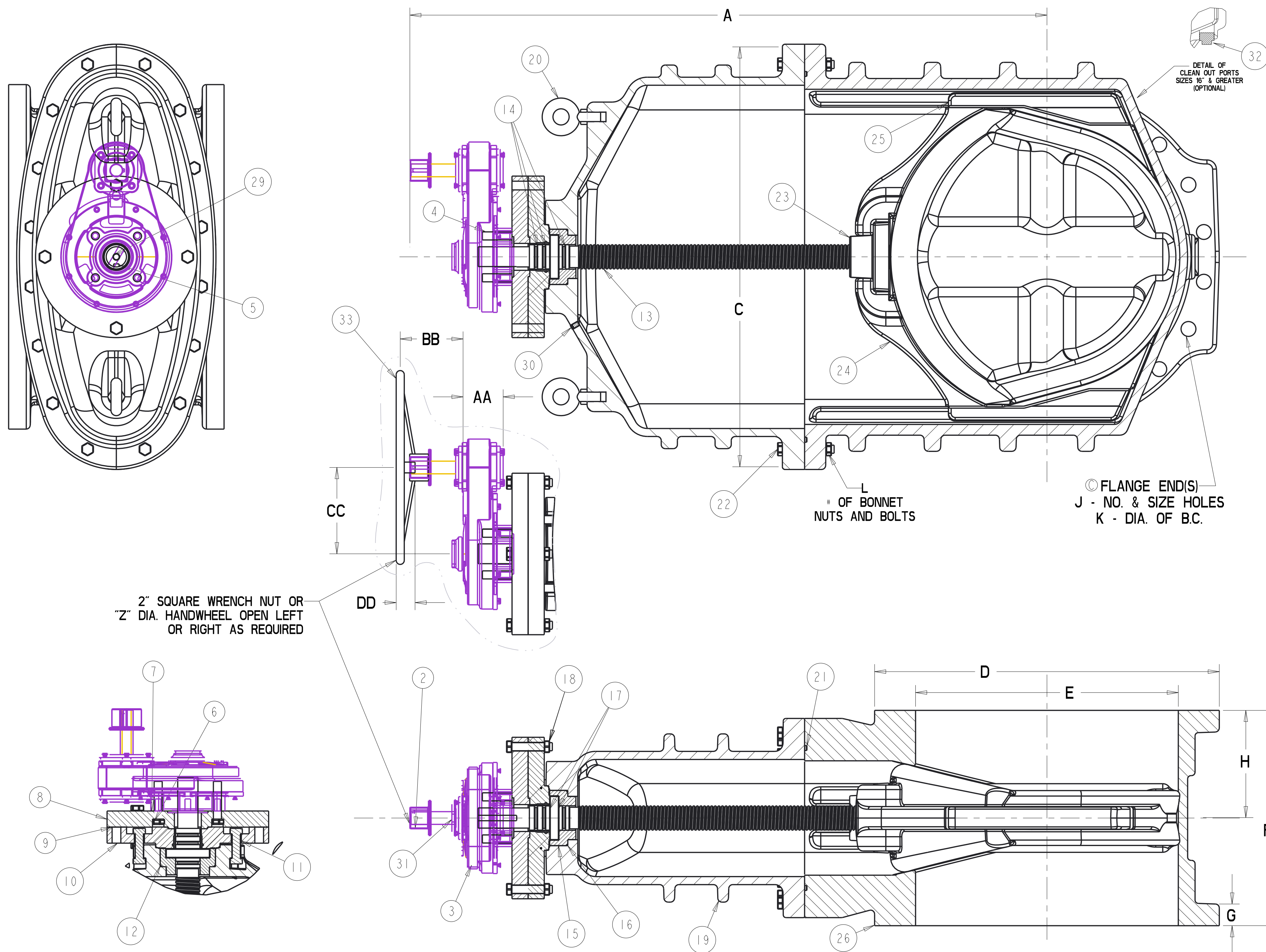

PARTS LIST					
ITEM	DESCRIPTION	REQ'D	MATERIAL	ASTM	CLASS B
2	WRENCH NUT	1	CAST IRON (SEE NOTE 4)	A126	
3	SPUR GEARING	1			
4	STEM NUT	1	BRASS		
5	KEY	1	STEEL		
6	SOCKET HEAD SCREW	4	316 STAINLESS STEEL		SEE NOTE 2
7	GASKET	1	RUBBER	D2000	
8	ADAPTER	1	STEEL	A36	
9	GASKET	1	RUBBER	D2000	
10	STUFFING BOX	1	STEEL	A36	
11	SOCKET HEAD BOLT & NUT	4	316 STAINLESS STEEL		SEE NOTE 2
12	O-RING	1	RUBBER	D2000	R34 16" EPDM 18"-36"
13	STEM	1	BRONZE		SEE NOTE 3
14	O-RING	3	RUBBER	D2000	R34 16" EPDM 18"-36"
15	BONNET BUSHING (SEE NOTE 5)	1	BRONZE	B62	ALLOY C83600
16	O-RING	1	RUBBER	D2000	R34 16" EPDM 18"-36"
17	WASHER	2	BRASS		
18	HEX BOLT & NUT	4	316 STAINLESS STEEL		SEE NOTE 2
19	BONNET	1	DUCTILE IRON	A536	
20	EYEBOLT	2	STEEL		GALVANIZED
21	O-RING	1	RUBBER	D2000	R34 16" EPDM 18"-36"
22	HEX BOLT & NUT	"L"	316 STAINLESS STEEL		SEE NOTE 2
23	DISC NUT	1	BRONZE	B62	ALLOY C83600
24	DISC	1			SEE NOTE 1
25	GUIDE CAP	2	ACETAL		M90
26	BODY - FLG ENDS	1	DUCTILE IRON	A536	
27	BODY - MJ ENDS	1	DUCTILE IRON	A536	
28	BODY FLG X MJ ENDS	1	DUCTILE IRON	A536	
29	HOLD-DOWN WASHER & BOLT	1	STEEL	SAE J429	ZINC PLATED
30	PIPE PLUG	1	316 STAINLESS STEEL		SEE NOTE 2
31	ACTUATOR PIPE PLUG	1	CAST IRON		
32	PIPE PLUG	2	SUPPLIED WHEN TAPPED		
33	HANDWHEEL	1	CAST IRON (SEE NOTE 4)	A126	CLASS B

- NOTES:
- RUBBER ENCAPSULATED DUCTILE IRON DISC  
RUBBER - SBR 14", 16" - EPDM (18" AND UP) ASTM D2000  
DUCTILE IRON ASTM A536
  - BOLTS - ASTM F593 - GROUP 2-CW  
NUTS - ASTM F594 - GROUP 2-CW
  - 14", 16" VALVE - BRONZE ALLOY ASTM B138 ALLOY C67600  
18" TO 36" VALVES - BRONZE ASTM B584 ALLOY C86400
  - MANUFACTURER'S OPTION TO UPGRADE MATERIAL TO DUCTILE IRON A536
  - BONNET BUSHING PRESENT ON 18" - 36" VALVES ONLY

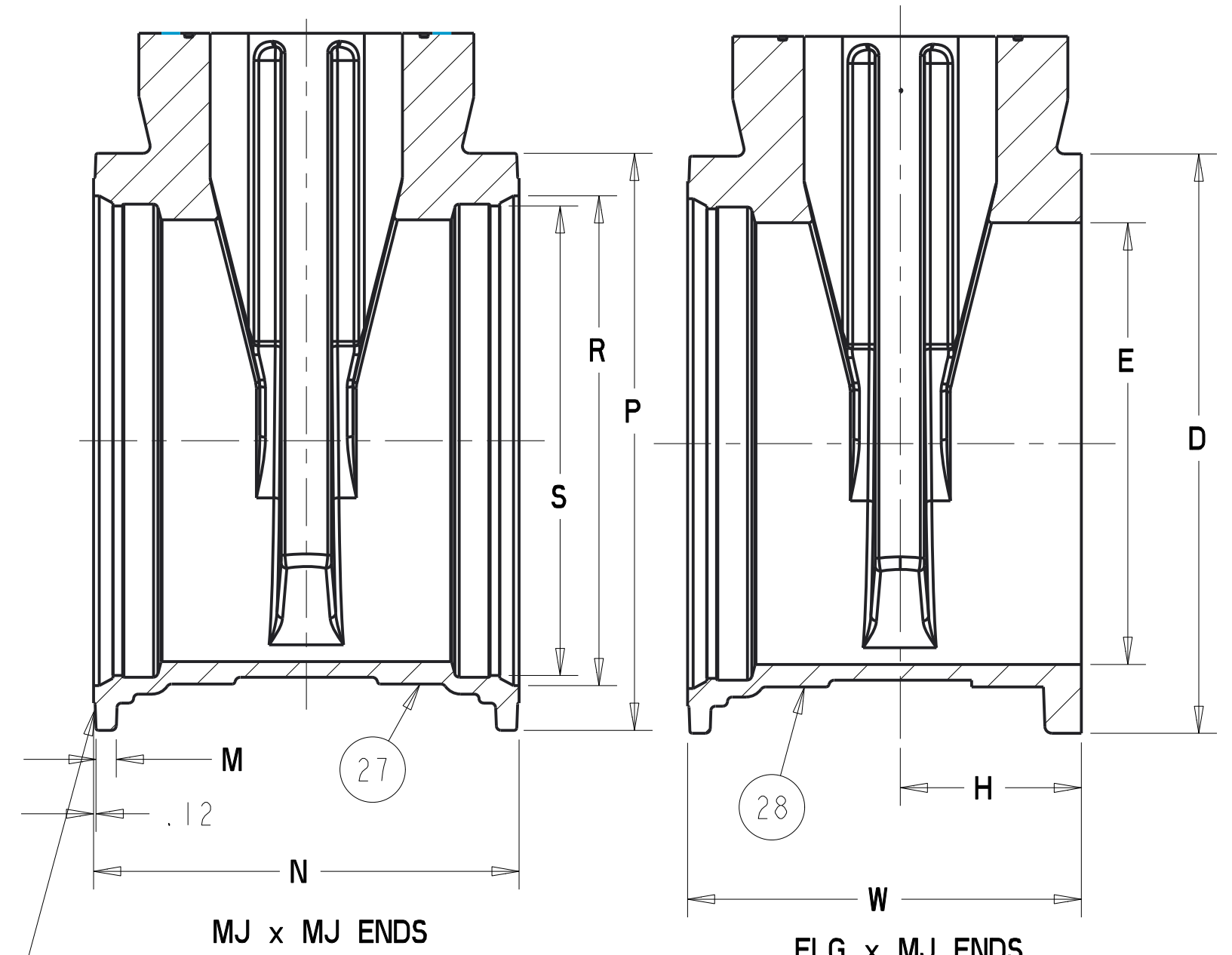

VALVE SIZE	A	C	D	E	F	G	H	J	K	L	M	N	P	R	S	W	X	Y	Z	AA	BB	CC	DD	TURNS TO OPEN ALL SIZES 4:1	WEIGHT
14	40.49	24.92	21.00	14.38	15.06	1.42	7.53	12-1.12	18.75	10	1.06	19.75	20.62	16.54	15.44	17.41	12-.88	18.75	12	4.53	7.55	8.03	1.85	178	800
16	43.58	26.58	23.50	16.00	16.06	1.59	8.03	16-1.12	21.25	12	1.10	19.75	22.56	18.40	17.28	17.91	12-.88	21.00	12	4.53	7.55	8.03	1.85	201	1000
18	49.41	30.50	25.00	18.38	17.00	1.69	8.50	16-1.25	22.75	12	1.06	21.00	24.88	20.74	19.64	19.00	12-.88	23.25	12	4.53	7.55	8.03	1.85	234	1,350
20	53.01	33.75	27.50	20.38	18.00	1.78	9.00	20-1.25	25.00	12	1.60	21.50	27.25	22.84	21.74	19.75	14-.88	25.50	12	4.53	7.55	8.03	1.85	258	1,800
24	59.15	39.50	32.00	24.38	20.00	2.00	10.00	20-1.38	29.50	16	1.12	23.50	31.88	27.05	25.94	21.75	16-.88	30.00	12	4.53	7.55	8.03	1.85	308	2,300
30	70.81	48.00	38.75	30.38	26.00	2.12	13.00	28-1.38	36.00	20	1.25	33.50	39.53	33.47	32.18	29.75	20-1.125	36.88	18	4.53	7.55	8.03	1.85	381	5,000
36	83.08	56.50	46.00	36.38	30.00	2.37	15.00	32-1.63	42.75	24	1.45	37.50	46.41	39.77	38.48	33.75	24-1.125	43.75	18	4.53	7.55	8.03	1.85	455	8,400

**APPROVED**  
By Jason W. Bradley at 11:10 am, May 19, 2015

SR BY: AO	5/15/15	UNLESS OTHERWISE NOTED	THIRD ANGLE PROJECTION	C.D. NO.
CHNG: BB	5/15/15	BREAK CAST CORNERS!		PART. NO.
ENGR: MS	5/15/15	BREAK MECH CORNERS!		
MFR:		TOLERANCES	PURCH. NO.	FINISH ASSY
MFG:		UNLESS OTHERWISE NOTED	REF. NO.	SCALE
TOOL:		LINER	ANGULAR	NONE
FBY:		±	STR. NO.	
NOTED				
MAT'L		DESCR.		NUMBER
		14" - 36" RWGV NRS W/SPUR GEARING W/316SS FASTENERS		7225