

7343 4 IN - 12 IN T-2361 M.J. RESILIENT WEDGE TAPPING VALVE NRS - AWWA - UL - FM - 350W - 700 TEST

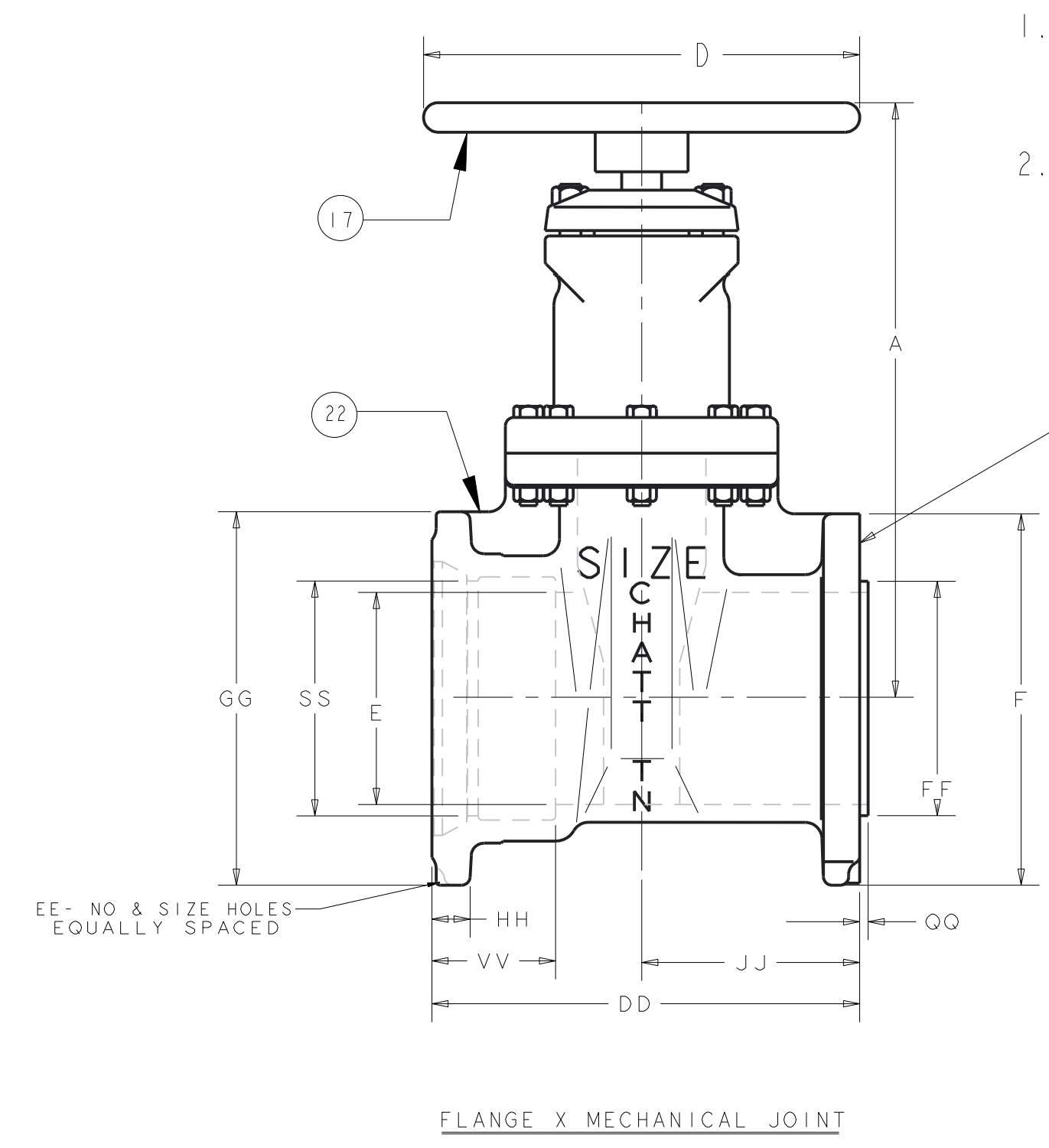
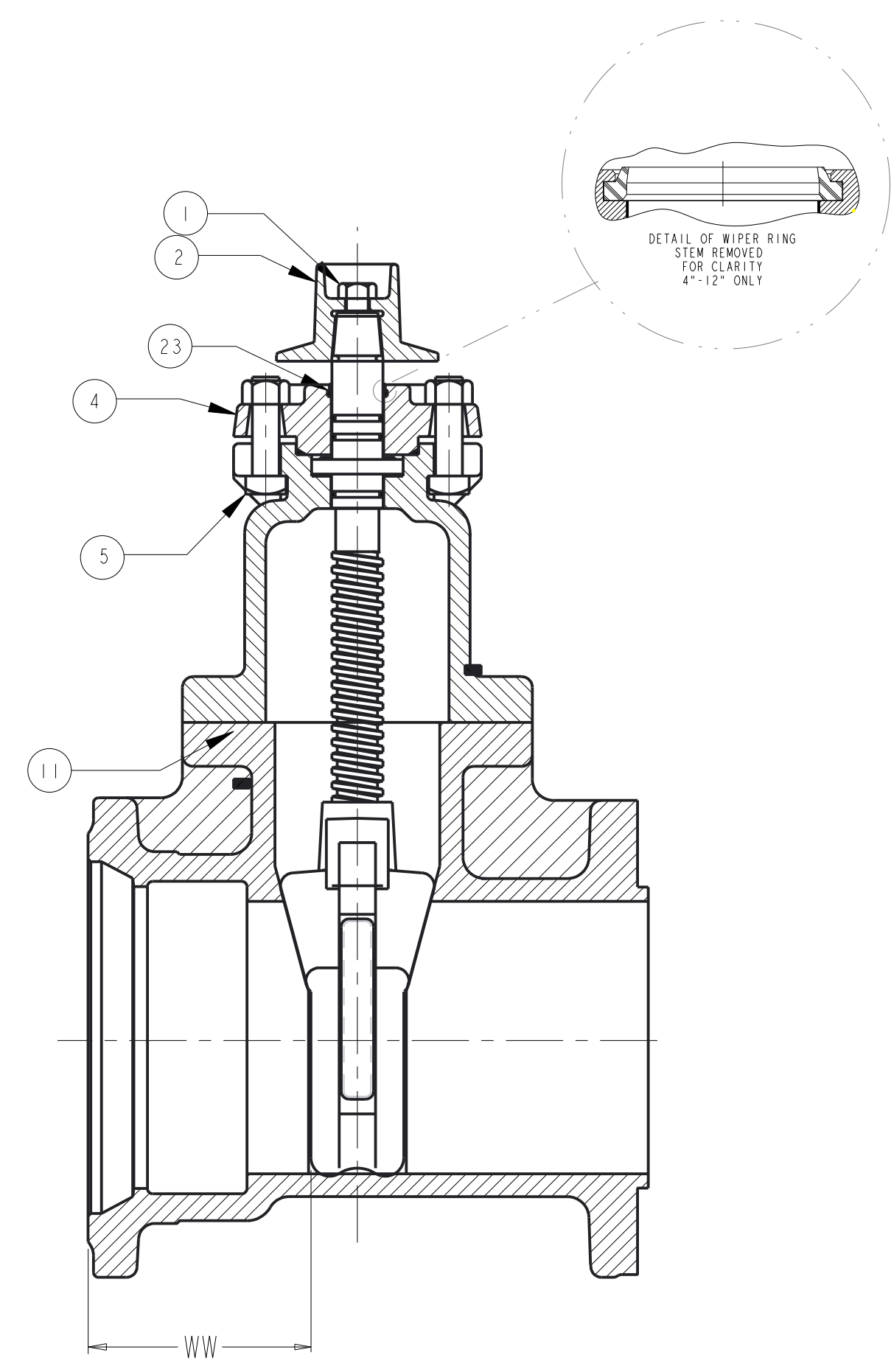
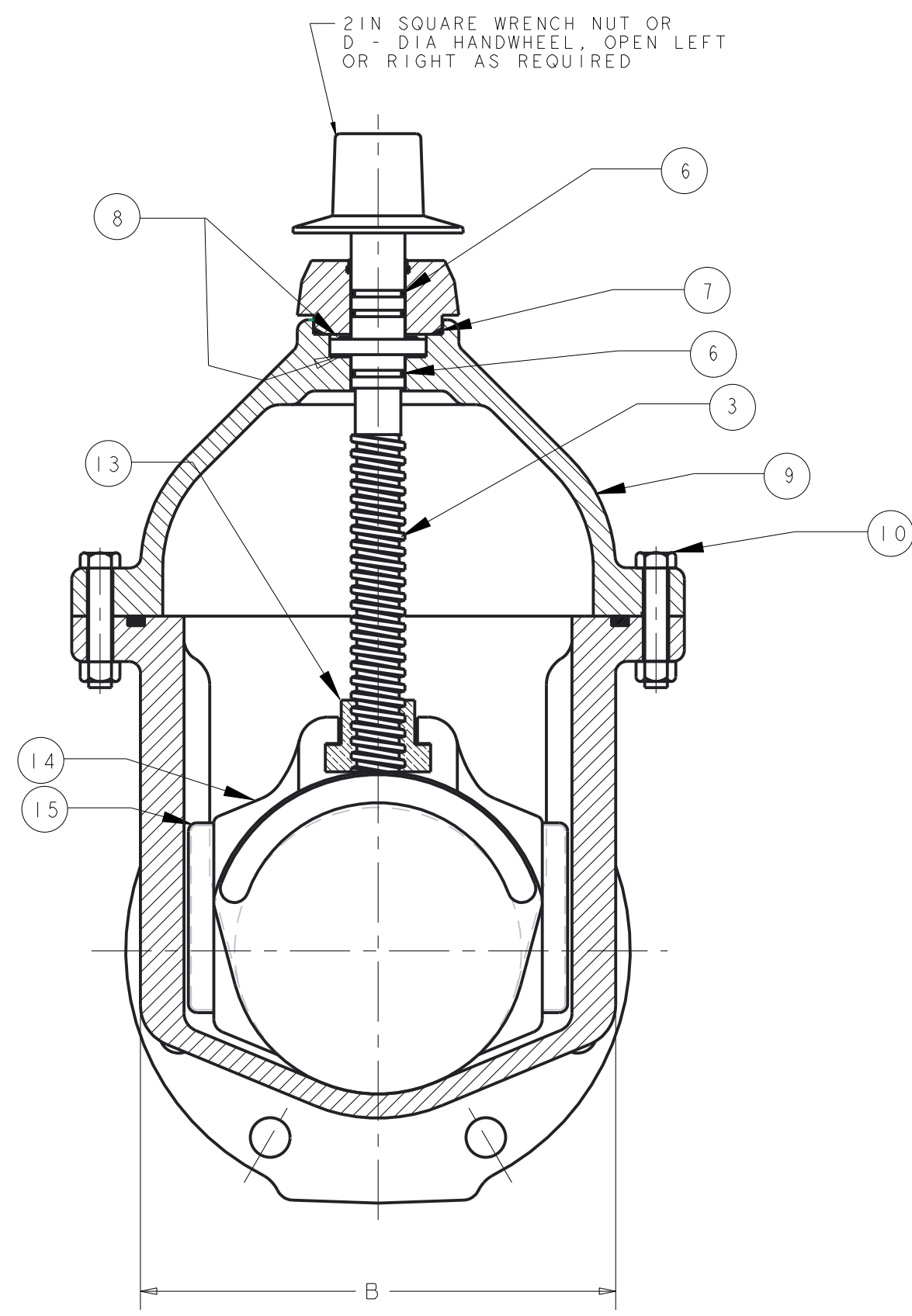
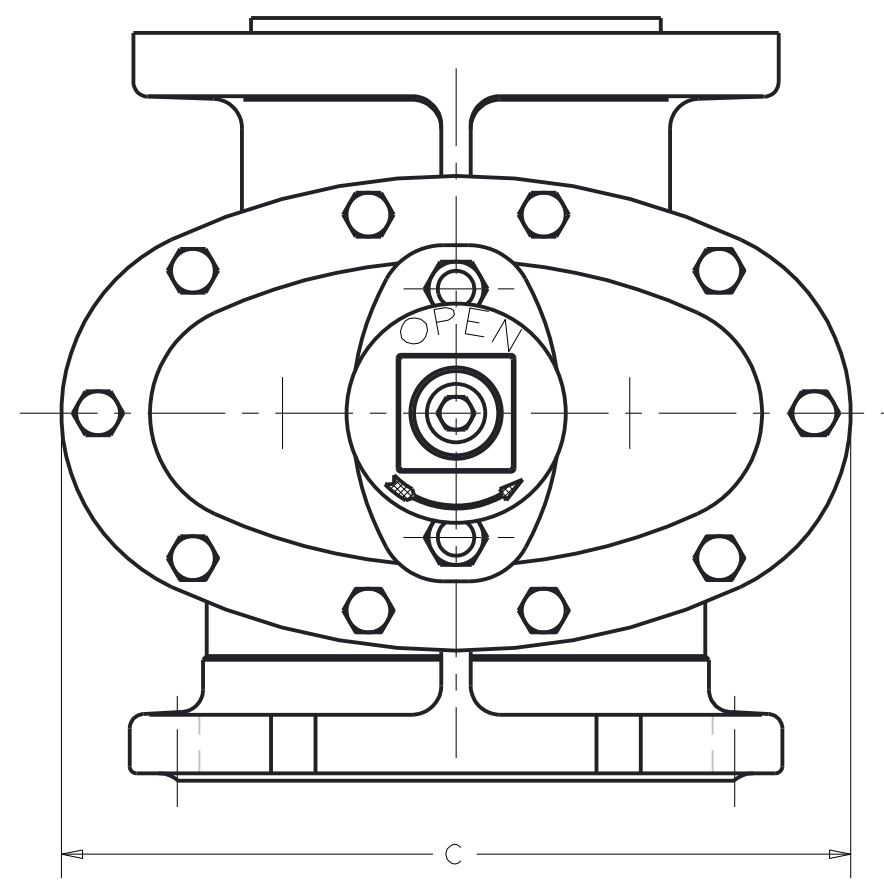

PARTS LIST					
ITEM	DESCRIPTION	REQ'D	MATERIAL	ASTM	
1	CAP SCREW	1	304 STN. STL.	A193	GRADE B8
2	WRENCH NUT	1	DUCTILE IRON	A536	
3	STEM	1	BRONZE	B138	ALLOY C67600
4	STUFFING BOX	1	DUCTILE IRON	A536	
5	STUFFING BOX BOLTS STUFFING BOX NUTS	2	304 STN. STL.	F593 F594	GROUP 1-SH GROUP 1-CW
6	O-RING	3	RUBBER	D2000	NITRILE
7	O-RING	1	RUBBER	D2000	NITRILE
8	ANTI-FRICTION WASHER	2	ACETAL		
9	BONNET	1	DUCTILE IRON	A536	
10	BONNET BOLTS BONNET NUTS	"Z"	304 STN. STL.	F593 F594	GROUP 1-SH GROUP 1-CW
11	BONNET GASKET (O-RING)	1	RUBBER	D2000	NITRILE
13	DISC NUT	1	BRONZE	B584	ALLOY C89833
14	DISC	1	SEE NOTES 1 & 2		
15	GUIDE CAP	2	ACETAL		
17	HANDWHEEL	1	CAST IRON [SEE NOTE 2]	A126	CLASS B
22	BODY (M.J. TAPPING)	1	DUCTILE IRON	A536	
23	WIPER RING (4" - 12")	1	RUBBER	D2000	NITRILE

1. RUBBER ENCAPSULATED DUCTILE IRON DISC  
DUCTILE IRON - ASTM A536 65-45-12 OR 70-50-05  
RUBBER - SBR - ASTM D2000

2. MANUFACTURER'S OPTION TO UPGRADE MAT'L  
TO D1 - A536 GR 65-45-12 OR 70-50-05

DIMENSIONS FOR US PIPE RESILIENT WEDGE VALVE - INCHES (THIS DRAWING ONLY)

VALVE SIZE	A	B	C	D	E	F	Z	DD	EE	FF	GG	HH	JJ	QQ	SS	TT	VV	WW	TURNS TO OPEN	WEIGHT (lbs)
4	14.19	8.25	10.79	8.00	4.30	9.00	4	11.73	4 - .88	4.984 4.954	9.12	1.12	6.05	0.18	4.92	8 - .75	3.21	4.47	14	99
6	18.00	10.50	13.50	11.00	6.30	11.00	6	12.75	6 - .88	6.984 6.954	11.12	1.18	6.50	0.25	7.03	8 - .88	3.03	4.91	20.5	160
8	21.50	13.21	16.36	13.00	8.30	13.50	6	14.37	6 - .88	8.984 8.954	13.38	1.30	7.50	0.25	9.17	8 - .88	3.22	5.46	26.5	254
10	25.50	16.48	19.99	14.00	10.30	16.00	8	15.70	8 - .88	10.984 10.954	15.69	1.25	8.27	0.25	11.22	12 - 1.00	2.50	5.93	33	412
12	28.62	16.83	21.00	16.00	12.30	19.00	8	14.99	8 - .88	12.984 12.954	17.94	1.38	7.00	0.25	13.32	12 - 1.00	2.88	6.15	38.5	525

DR BY: AO	9/6/16	UNLESS OTHERWISE NOTED	THIRD ANGLE PROJECTION	C.D. NO.
CHKD: BB	9/6/16	BREAK CAST CORNERS!		PART. NO.
ENGR: MS	9/6/16	BREAK MACH CORNERS!		
MFR:		TOLERANCES	PURCH: NO	FINISH: ASSY
MFG:		UNLESS OTHERWISE NOTED	REF. NO.	SCALE: NONE
TOOL:		LINEAR ±	ANGULAR ±	STR. NO.
FDRT:				
MAT'L: NOTED		DESCR: 4 IN - 12 IN RWTV T-2361		NUMBER: 7343

**APPROVED**  
By MATTHEW SLIGER at 10:04 am, Sep 29, 2016