

PARTS LIST					
ITEM	DESCRIPTION	REQ'D	MATERIAL	ASTM	
1	CAP SCREW	1	316 STAINLESS STEEL		SEE NOTE 3
2	WRENCH NUT	1	CAST IRON (SEE NOTE 4)	A126	CLASS B
3	STUFFING BOX	1	DUCTILE IRON	A536	
4	HEX BOLT & NUT	"AA"	316 STAINLESS STEEL		SEE NOTE 3
5	O-RING	1	RUBBER	D2000	SEE NOTE 6
6	STEM	1			SEE NOTE 1
7	O-RING	3	RUBBER	D2000	SEE NOTE 6
8	WASHER	2	BRASS		
9	BONNET	1	DUCTILE IRON	A536	
10	EYEBOLT	2	STEEL		GALVANIZED
11	BONNET BUSHING	1	BRONZE	B62	SEE NOTE 5
12	O-RING	1	RUBBER	D2000	SEE NOTE 6
13	HEX BOLT & NUT	"L"	316 STAINLESS STEEL		SEE NOTE 3
14	O-RING	1	RUBBER	D2000	SEE NOTE 6
15	DISC NUT	1	BRONZE	B62	
16	DISC	1			SEE NOTE 2
17	GUIDE CAP	2	ACETAL		
18	BODY FL x MJ	1	DUCTILE IRON	A536	
19	BODY MJ x MJ	1	DUCTILE IRON	A536	
20	BODY FL x FL	1	DUCTILE IRON	A536	
21	PIPE PLUG	2	SUPPLIED WHEN TAPPED		
22	BODY TFL X MJ	1	DUCTILE IRON	A536	

- NOTES:
- 14" TO 16" VALVES - MANGANESE BRONZE ASTM B138 ALLOY C67600  
18" TO 24" VALVES - MANGANESE BRONZE ASTM B584 ALLOY 86400
  - RUBBER ENCAPSULATED DUCTILE IRON DISC  
RUBBER - 14" TO 16" SBR ASTM D2000 18" TO 24" EPDM ASTM D2000  
DUCTILE IRON ASTM A536 GRADE 65-45 MINIMUM
  - BOLTS ARE - ASTM F593 GROUP 2-CW  
NUTS - ASTM F594 GROUP 2-CW
  - MANUFACTURER'S OPTION TO UPGRADE MATERIAL TO DUCTILE IRON A536 65-45 MINIMUM
  - 14" TO 16" VALVES DO NOT HAVE A BONNET BUSHING
  - 14" TO 16" NITRILE ASTM D2000  
18" TO 24" EPDM ASTM D2000

2" SQUARE WRENCH NUT OR  
"Z" DIA. HANDWHEEL OPEN LEFT  
OR RIGHT AS REQUIRED

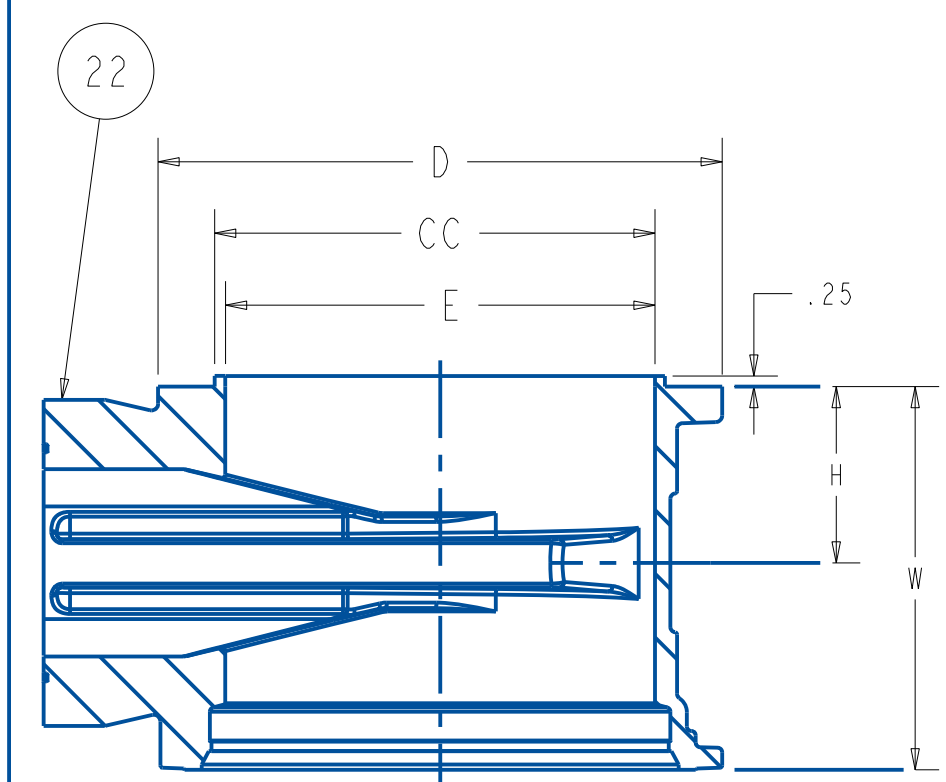

RWTV BODY  
FLG x MJ ENDS  
SCALE .125:1

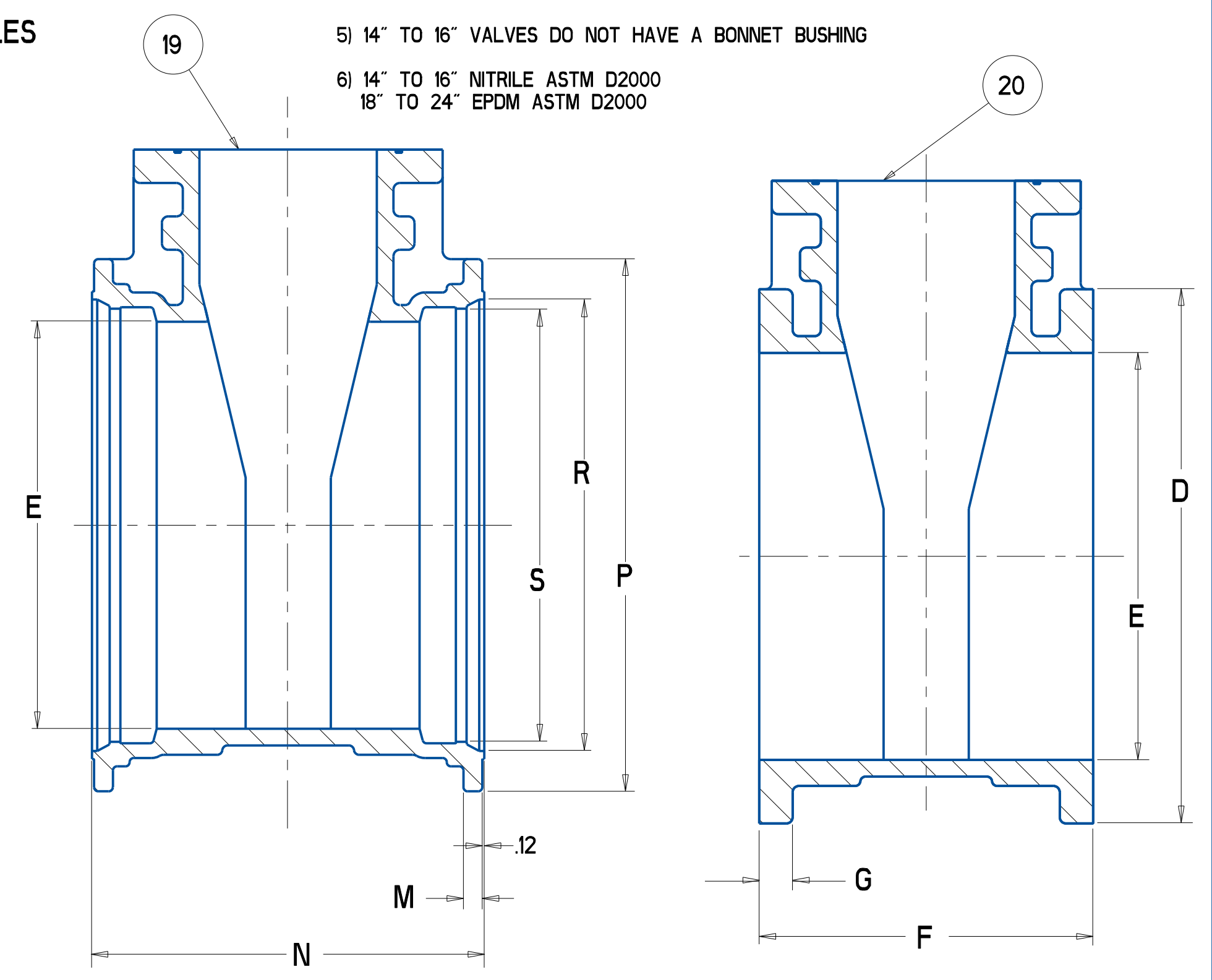

VALVE SIZE	A	C	D	E	F	G MINIMUM	H	J	K	L	M	N	P	R	S	W	X	Y	Z	AA	CC	TURNS TO OPEN
14	32.75	24.92	21.00	14.38	15.06	1.00 (B)	7.53	12 - .112	18.75	10	150	19.75	20.62	16.54	15.44	17.41	10 - .88	18.75	18.00	2	15.23	44
16	37.88	26.58	23.50	16.00	16.06	1.00 (B)	8.03	16 - .112	21.25	12	150	19.75	22.56	18.40	17.28	17.91	12 - .88	21.00	18.00	2	17.23	49
18	44.19	30.50	25.00	18.38	17.00	1.00 (B)	8.50	16 - 1.25	22.75	12	150	21.00	24.88	20.74	19.64	19.00	12 - .88	23.25	18.00	4	19.45	57
20	48.25	33.75	27.50	20.38	18.00	1.13 (B)	9.00	20 - 1.25	25.00	12	160	21.50	27.25	22.84	21.74	19.75	14 - .88	25.50	20.00	4	21.45	63
24	53.88	39.50	32.00	24.38	20.00	1.19 (B)	10.00	20 - 1.38	29.50	16	112	23.50	31.88	27.05	25.94	21.75	16 - .88	30.00	30.00	4	25.43	75

7431

**APPROVED**  
By Matt Sliger at 8:36 am, Aug 13, 2019

SR BY: AO	10/4/17	UNLESS OTHERWISE NOTED	THIRD ANGLE PROJECTION	C. D. NO.
CHKD: BB	10/4/17	BREAK CAST CORNERS!		
ENGR: MS	10/4/17	BREAK MACH CORNERS!		
MFR:		TOLERANCES	NO FINISH	PART. NO.
MFG:		UNLESS OTHERWISE NOTED	REF. NO.	SCALE
TOOL:		LINEAR	STR. NO.	NONE
FBY:		ANGULAR		
MAT'L				
DESCR.				
14"-24" RWGV'S				
NUMBER				
7431				