

PARTS LIST					
ITEM	DESCRIPTION	REQ'D	MATERIAL	ASTM	
1	CAP SCREW	1	316 STAINLESS STEEL	F593	GROUP 2-CW
2	WRENCH NUT	1	CAST IRON	A126	CLASS B
3	STEM	1	MANGANESE BRONZE	B138	ALLOY 676
4	STUFFING BOX	1	DUCTILE IRON	A536	
5	"O" RING	3	RUBBER	D2000	MUELLER R34
6	"O" RING	1	RUBBER	D2000	MUELLER R34
7	ANIT-FRICTION WASHER	2	BRASS		
8	HEX BOLT	2	316 STAINLESS STEEL	F593	GROUP 2-CW
	HEX NUT	2	316 STAINLESS STEEL	F594	GROUP 2-CW
9	BONNET	1	DUCTILE IRON	A536	
10	HEX BOLT	12	316 STAINLESS STEEL	F593	GROUP 2-CW
	HEX NUT	12	316 STAINLESS STEEL	F594	GROUP 2-CW
11	"O" RING	1	RUBBER	D2000	MUELLER R34
12	DISC NUT	1	BRONZE	B62	UNS 83600
13	DISC	1	SEE NOTE 1		
14	GUIDE CAP	2	ACETAL		
15	FLG x FLG BODY	1	DUCTILE IRON	A536	
16	MJ x MJ BODY	1	DUCTILE IRON	A536	
17	FLG x MJ BODY	1	DUCTILE IRON	A536	
18	EYE BOLT	2	STEEL		ANSI B18.15
19	HEX NUT	2	STEEL	A536	GRADE B
20	SL x SL BODY	1	DUCTILE IRON	A536	
21	SL x FLG BODY	1	DUCTILE IRON	A536	

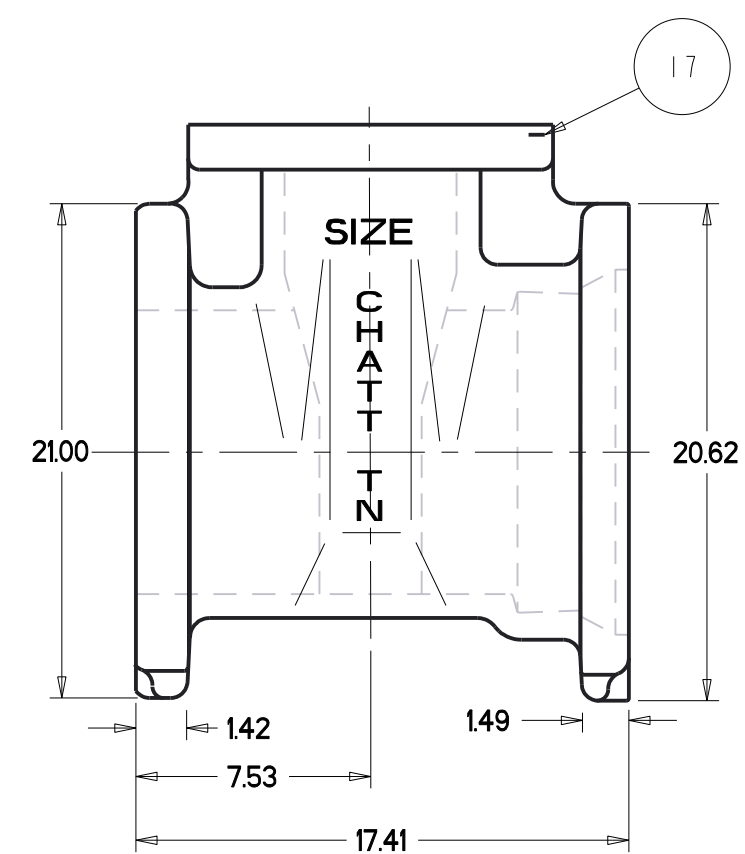

FLANGE X MECH JOINT ENDS

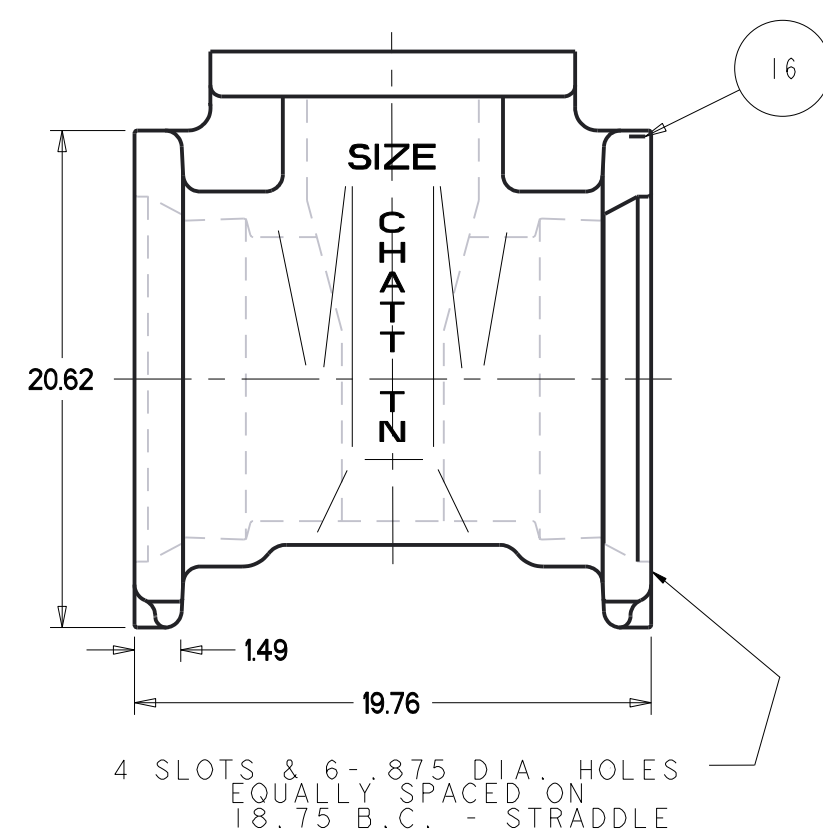

MECHANICAL JOINT ENDS

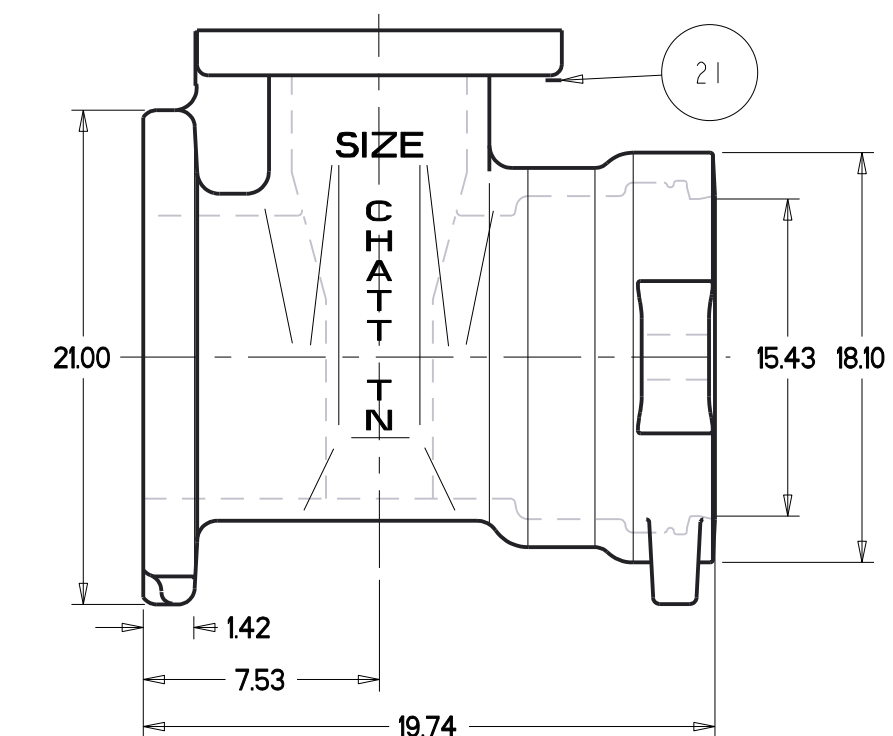
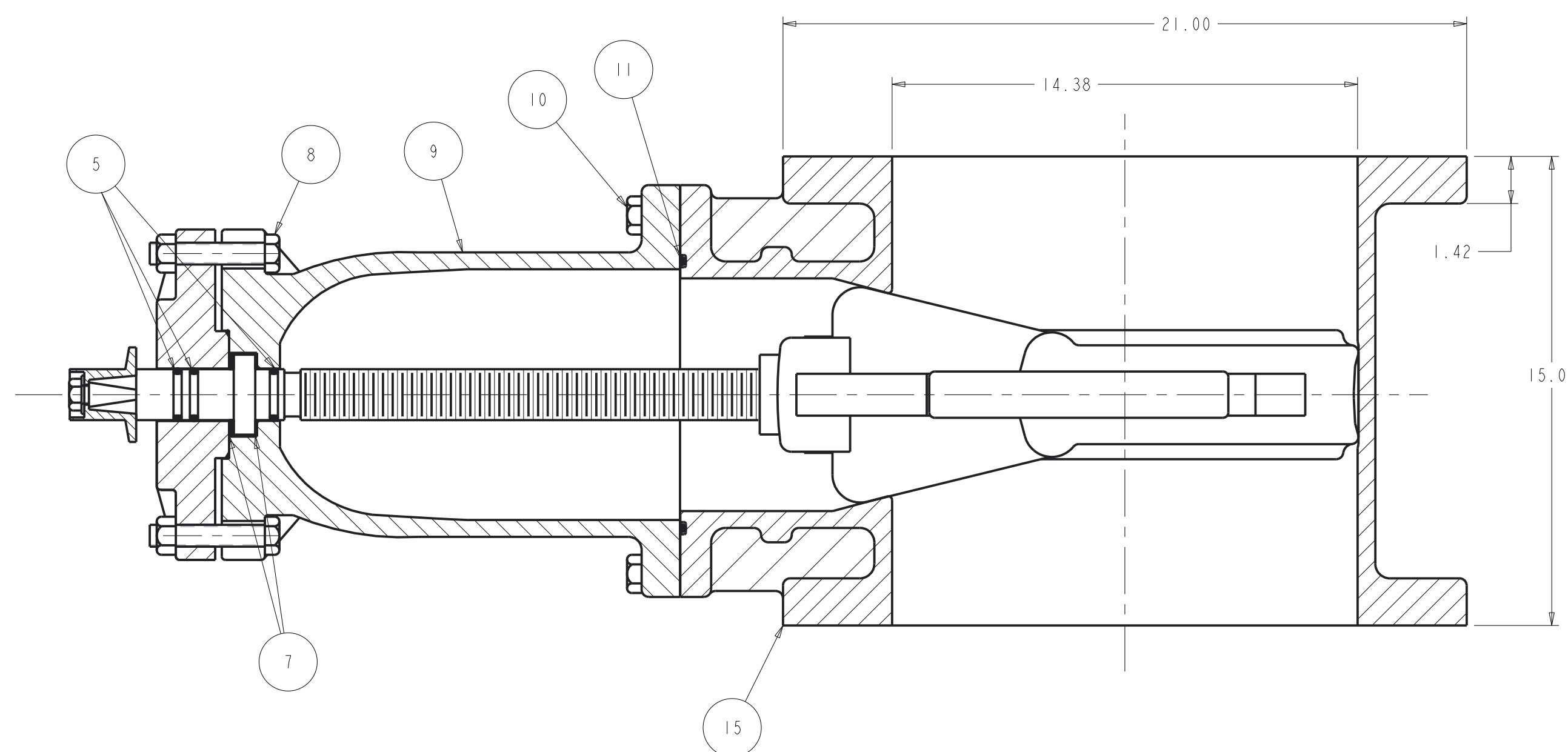

FLANGE X SLIP-ON ENDS

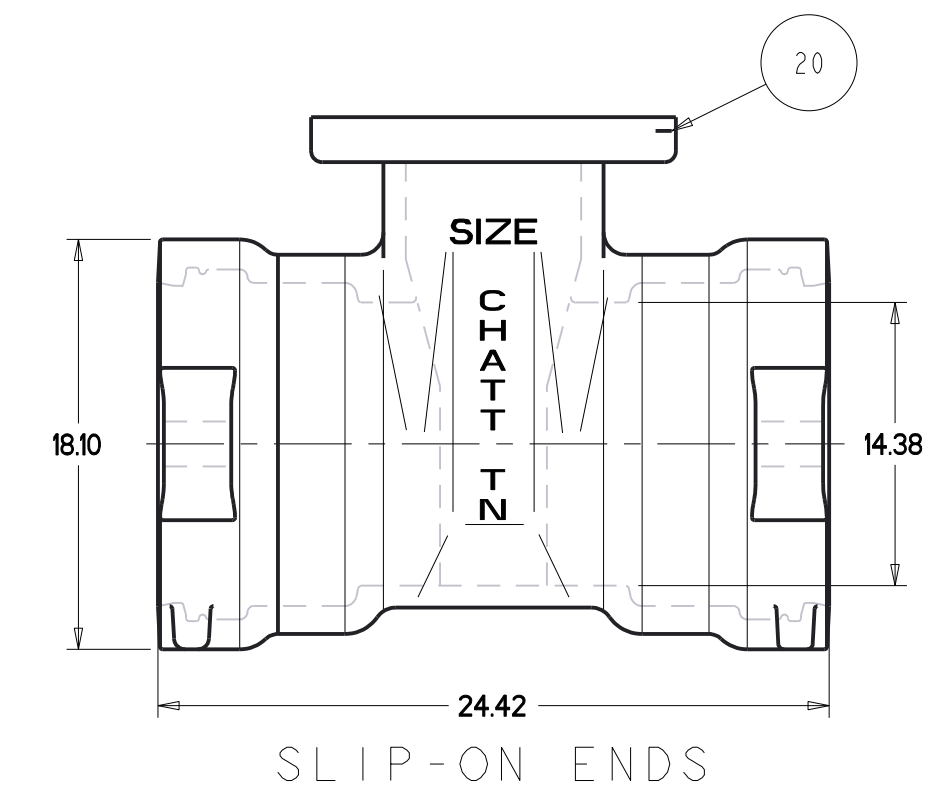

SLIP-ON ENDS

NOTE:
 1. RUBBER ENCAPSULATED DUCTILE IRON DISC
 DUCTILE IRON - ASTM A536 65-45-12
 RUBBER - MUELLER RUBBER SPEC R88 (SBR)

DR BY	AO	10/3/17	UNLESS OTHERWISE NOTED	THIRD ANGLE PROJECTION	C.D. NO.
CHKD	BD	10/3/17	BREAK CAST CORNERS!		PART. NO.
ENGR	MS	10/3/17	BREAK MACH CORNERS!		
MFR			TOLERANCES	PURCH. NO.	FINISH ASSY
MFG			UNLESS OTHERWISE NOTED	REF. NO.	SCALE
TOOL			LINEAR	25 : 1.00	
FBY			ANGULAR		
MAT'L NOTED			±	STR. NO.	
Mueller Co.		DESCR.	14" RWGV ALL END TYPES	NUMBER	7450

APPROVED
 By Matthew Sliger at 2:15 pm, Nov 07, 2017