

**SECTION B-B**  
SCALE 3 : 20

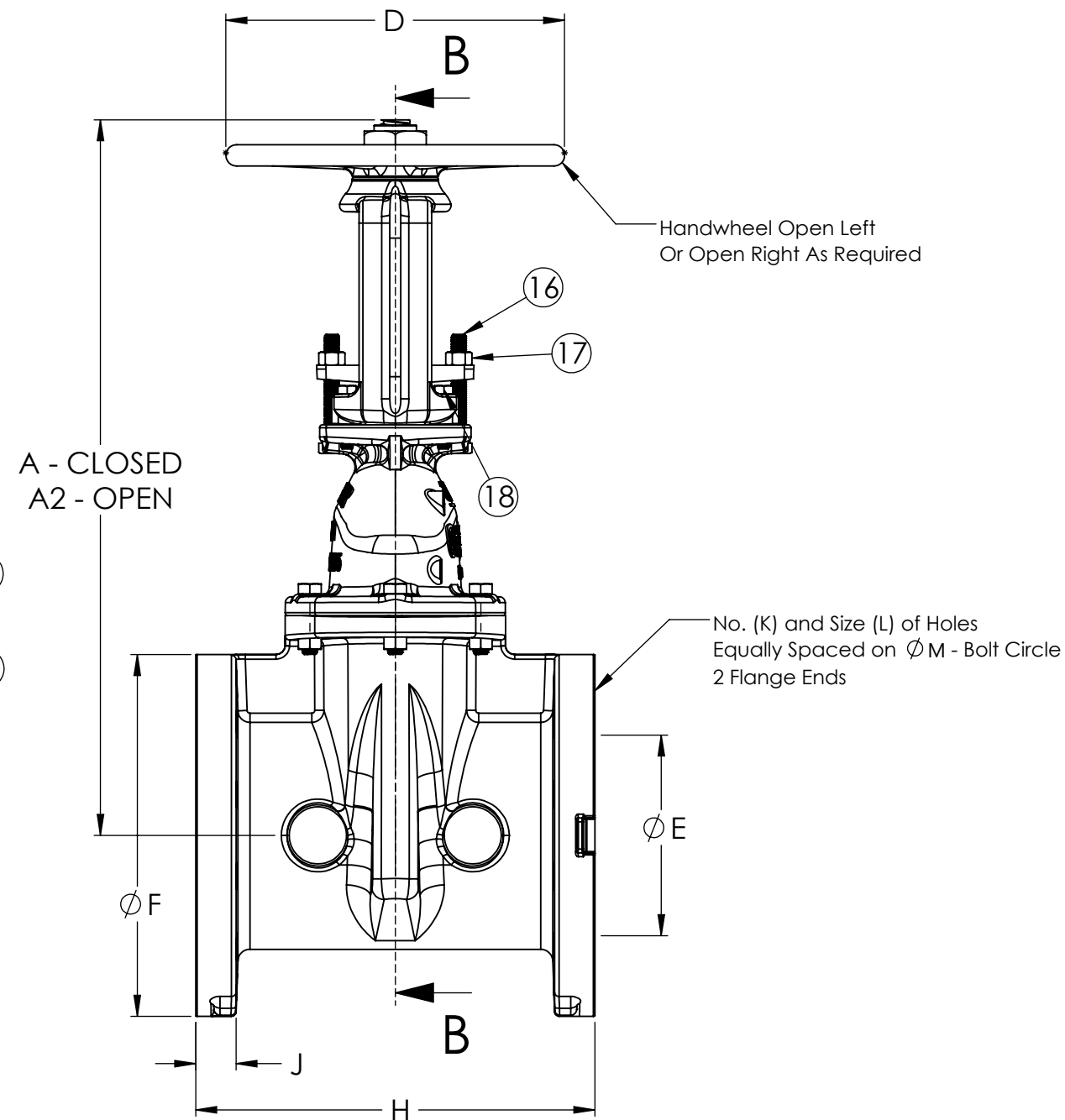

ITEM NO.	DESCRIPTION	QTY	MATERIAL	ASTM	NOTES
1	Cap Nut	1	Bronze	B62	Alloy C83600
2	Hand Wheel	1	Ductile Iron	A536	
3	Washer	2	Bronze		
4	Bush Nut	1	Bronze	B584	Alloy C84400
5	Yoke	1	Ductile Iron	A536	See Note 3
6	Stem	1	Bronze	See Note 1	
7	Gland Flange	1	Ductile Iron	A536	
8	Stem Packing	"T"	Lib. Flax		FED HH-P-106
9	Bonnet	1	Ductile Iron	A536	See Note 3
10	Bonnet O-Ring	1	Nitrile Rubber		R34
11	Body	1	Ductile Iron	A536	
12	Disc Nut	1	Bronze	B584	C89833 / NSF 372
13	Encapsulated Disc	1	See Note 2	D2000	
14	Disc Casting	1	Ductile Iron	A536	
15	Guide Cap	2	Acetal		
16	Gland Bolt	2	316 Stainless Steel	F593	Group 2-SH
17	Gland Nut	2	316 Stainless Steel	F594	Group 2-CW
18	Cap Screw	4	316 Stainless Steel	F593	Group 2-SH
19	Bonnet Bolts	"G"	316 Stainless Steel	F593	Group 2-SH
20	Bonnet Nuts	"G"	316 Stainless Steel	F594	Group 2-CW
21	Pin	1	304 Stainless Steel		
22	O-Ring	1	Nitrile Rubber		R34
23	Bonnet-Yoke Combo	1	Ductile Iron	A536	See Note 3

**Notes:**

- Bronze Stem Options:
  - Manganese - ASTM B138 Alloy C67600
  - Everdur - ASTM B98 Alloy C66100
- Rubber Encapsulated Ductile Iron Disc (ASTM A536)
  - SBR - ASTM D2000
  - EPDM - ASTM D2000
- 3", 4", & 6" OS&Y valves use a bonnet-yoke combo instead of a separate bonnet and yoke parts.

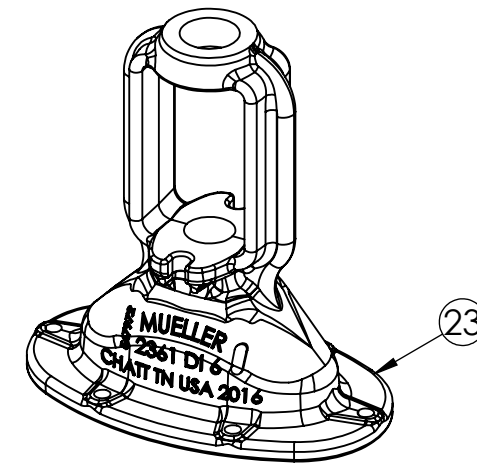

DIMENSIONS FOR RESILIENT WEDGE GATE VALVES - INCHES

Valve Size	A	A2	B	C	D	E	F	G	H	J	K	L	M	T	Turns to Open
3	15.66	19.31	6.01	8.63	7.00	3.30	8.27	4	11.12	1.13	8	.88	6.614	4	11
4	19.00	23.68	8.25	10.79	10.00	4.30	10.00	4	12.00	1.25	8	.88	7.874	4	14
6	24.50	31.38	10.50	13.50	12.00	6.30	12.60	6	15.88	1.44	12	.88	10.630	4	20.5
8	29.50	38.50	13.21	16.36	14.00	8.30	14.96	6	16.50	1.63	12	1.13	12.992	4	26.5
10	35.75	47.00	16.48	19.99	16.00	10.30	17.52	8	18.00	1.87	16	1.25	15.236	4	33
12	40.50	53.50	16.83	21.00	16.00	12.30	20.47	8	19.75	2.00	16	1.25	17.756	3	38.5

ECO 1980590

**APPROVED**

By **MATTHEW SLIGER** at 8:27 am, Sep 18, 2018

**MUELLER CONFIDENTIAL**

TITLE TO AND OWNERSHIP OF THIS ENGINEERING DATA REMAINS IN MUELLER CO. NO USE IS TO BE MADE OF THIS DATA EXCEPT AS SPECIFICALLY AUTHORIZED BY MUELLER CO. ASSENT ON THE PART OF THE RECIPIENTS TO THESE CONDITIONS IS PRESUMED.

UNLESS OTHERWISE SPECIFIED:

DIMENSIONS ARE IN INCHES  
TOLERANCES:  
FRACTIONAL ±  
ANGULAR: MACH ± BEND ±  
TWO PLACE DECIMAL ±  
THREE PLACE DECIMAL ±



MATERIAL

FINISH

	NAME	DATE
DRAWN	CSH	9/4/2018
CHECKED	AO	
ENG APPR.	MPS	
MFG APPR.		
Q.A.		

DESCR.		
R2361 RWGV Class 250		
SIZE	DWG. NO.	REV
<b>B</b>	7459	0
SCALE: 3:20	WEIGHT:	SHEET 1 OF 1

DO NOT SCALE DRAWING