

SECTION B-B
SCALE 3 : 20

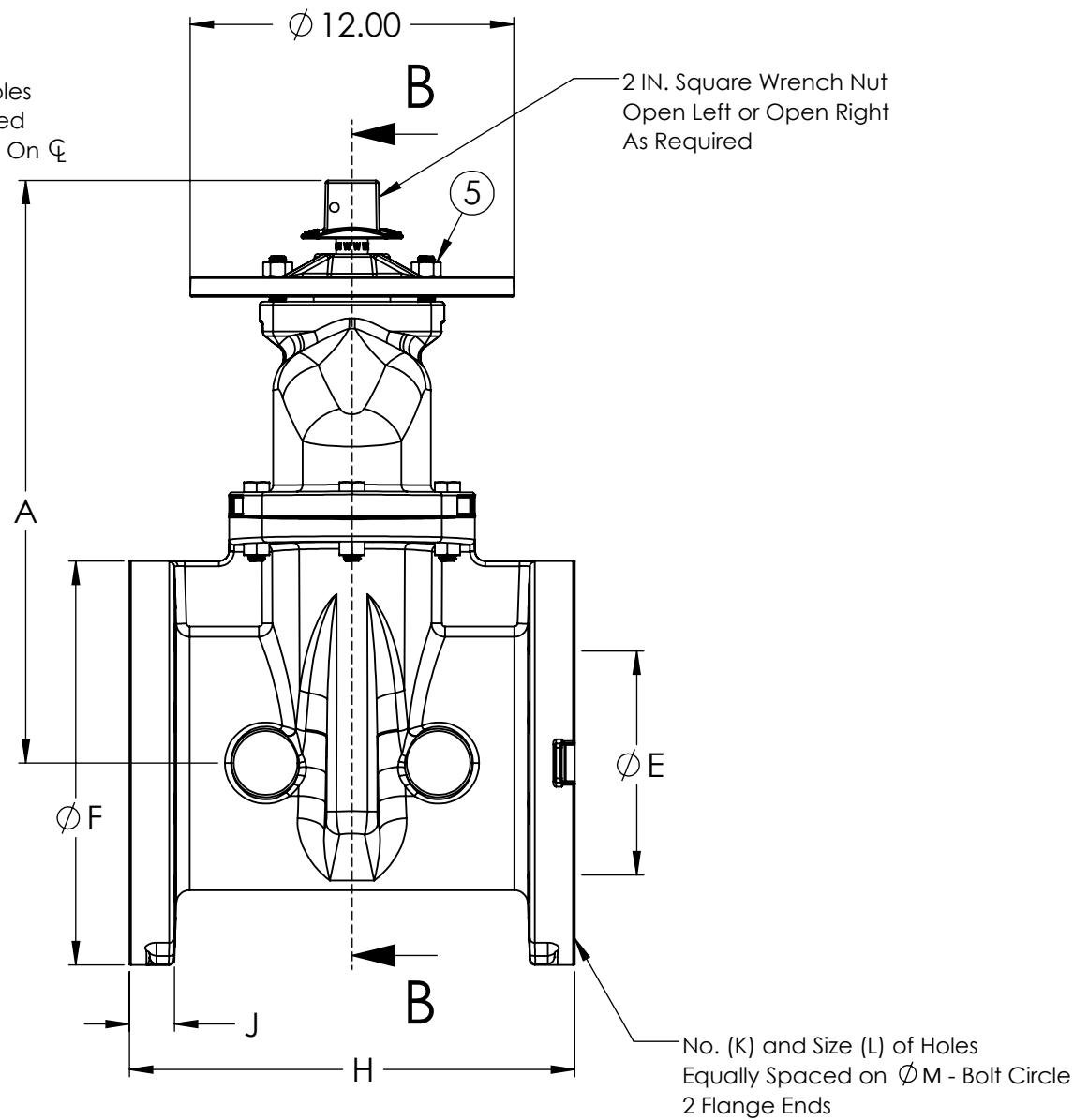

ITEM NO.	DESCRIPTION	QTY	MATERIAL	ASTM	NOTES
1	Cap Screw	1	316 Stainless Steel	F593	Group 2-CW
2	Wrench Nut	1	Ductile Iron	A536	
3	Stem	1	Manganese Bronze	B138	Alloy C67600
4	Stuffing Box	1	Ductile Iron	A536	
5	Stuffing Box Bolts Stuffing Box Nuts	2	316 Stainless Steel	F593 F564	Group 2-CW
6	O-Ring	3	Nitrile Rubber	D2000	
7	O-Ring	1	Nitrile Rubber	D2000	
8	Anti-Friction Washer	2	Acetal		
9	Bonnet	1	Ductile Iron	A536	
10	Bonnet Bolts Bonnet Nuts	"G"	316 Stainless Steel	F593 F594	Group 2-CW
11	Bonnet O-Ring	1	Nitrile Rubber	D2000	
12	Disc Nut	1	Bronze	B584	
13	Encapsulated Disc	1	See Note 2		
14	Guide Cap	2	Acetal		
15	Body	1	Ductile Iron	A536	

Notes:

- Bronze Stem Options:
- Manganese - ASTM B138 Alloy C67600
- Everdur - ASTM B98 Alloy C66100
- Rubber Encapsulated Ductile Iron Disc (ASTM A536)
- SBR - ASTM D2000
- EPDM - ASTM D2000
- Manufacturer's Option to Upgrade Material to Ductile Iron ASTM A536 65-45-12 or 70-50-05

DIMENSIONS FOR RESILIENT WEDGE GATE VALVES - INCHES

Valve Size	A	B	C	E	F	G	H	J	K	L	M	Turns to Open
3	12.38	6.01	8.63	3.30	8.27	4	11.12	1.13	8	.88	6.614	11
4	14.19	8.25	10.79	4.30	10.00	4	12.00	1.25	8	.88	7.874	14
6	18.00	10.50	13.50	6.30	12.60	6	15.88	1.44	12	.88	10.630	20.5
8	21.50	13.21	16.36	8.30	14.96	6	16.50	1.63	12	1.13	12.992	26.5
10	25.50	16.48	19.99	10.30	17.52	8	18.00	1.87	16	1.25	15.236	33
12	28.62	16.83	21.00	12.30	20.47	8	19.75	2.00	16	1.25	17.756	38.5

ECO 2190493

APPROVED

By **MATTHEW SLIGER** at 8:28 am, Sep 18, 2018

MUELLER CONFIDENTIAL

TITLE TO AND OWNERSHIP OF THIS ENGINEERING DATA REMAINS IN MUELLER CO. NO USE IS TO BE MADE OF THIS DATA EXCEPT AS SPECIFICALLY AUTHORIZED BY MUELLER CO. ASSENT ON THE PART OF THE RECIPIENTS TO THESE CONDITIONS IS PRESUMED.

UNLESS OTHERWISE SPECIFIED:

DIMENSIONS ARE IN INCHES
TOLERANCES:
FRACTIONAL ±
ANGULAR: MACH ± BEND ±
TWO PLACE DECIMAL ±
THREE PLACE DECIMAL ±



MATERIAL

FINISH

	NAME	DATE
DRAWN	CSH	9/5/2018
CHECKED	AO	
ENG APPR.	MPS	
MFG APPR.		
Q.A.		

DESCR.		
P2362 RWGV Class 250		
SIZE	DWG. NO.	REV
B	7507	0
SCALE: 3:20	WEIGHT:	SHEET 1 OF 1

DO NOT SCALE DRAWING