

SECTION A-A

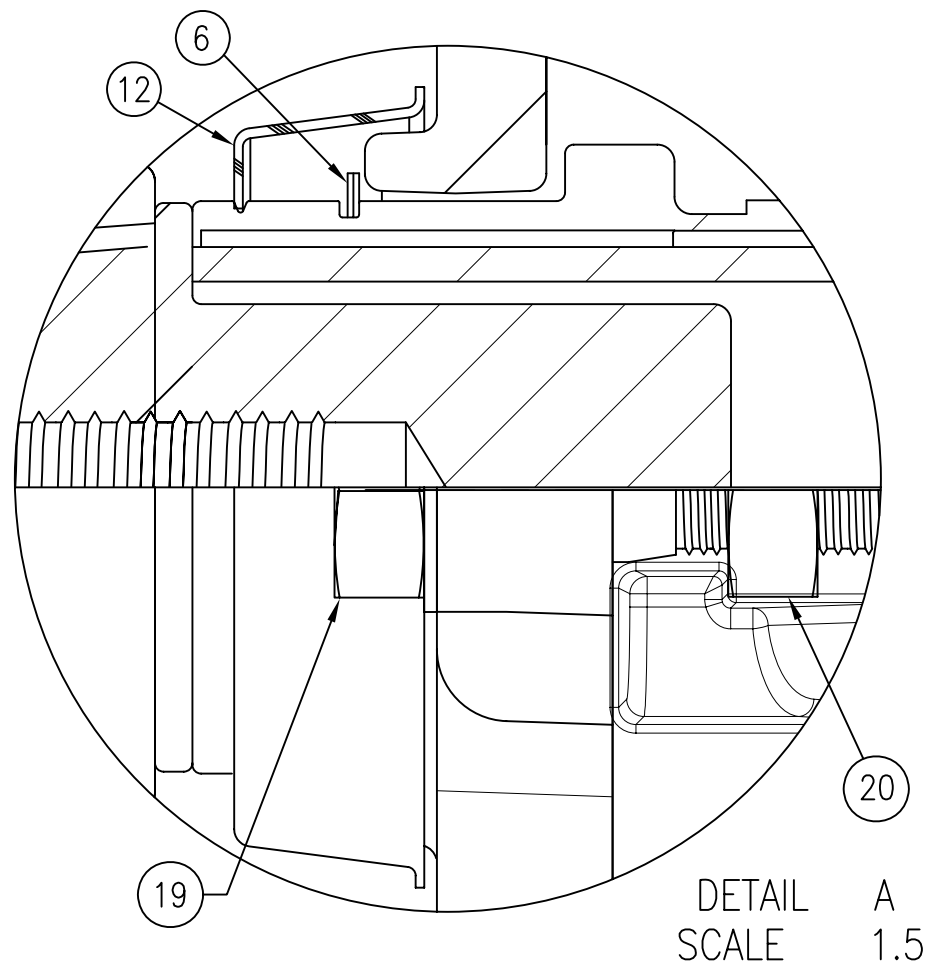

DETAIL A
SCALE 1.5

ITEM No.	PART NO.	DESCRIPTION	MATERIAL	MATERIAL STANDARD
1	290144	SHUT TARGET	PLASTIC	ZYTEL
2	290145	OPEN TARGET	PLASTIC	ZYTEL
3	290158	COTTER PIN (SHORT)	BRASS	ASTM B21
4	290155	COUPLING	STEEL	ASTM A500 GR.B
5	290154	COTTER PIN (LONG)	BRASS	ASTM B21
6	290157	RETAINING RING	STAINLESS STEEL	AISI 302
7	197688	WASHER	STEEL/ZINC PLATED	
8	198585	EYEBOLT	STEEL/ZINC PLATED	
9	190939	HEX NUT	STEEL/ZINC PLATED	ASTM A563 GR.A
10	148767-1	HANDWHEEL	DUCTILE IRON	ASTM A536 GR.65-45-12
11	148691	OPERATING NUT	DUCTILE IRON	ASTM A536 GR.65-45-12
12	290143	CAP	POLYPROPYLENE	
13	190330	SPRING PIN	STAINLESS STEEL	AISI 420
14	148634	THREADED SLEEVE	PLASTIC	ZYTEL
15	148638	UPPER STEM	STEEL	ASTM A513
16	198582	PIPE PLUG - HEX SOCKET	STEEL	
17	240556	POST HEAD	CAST IRON	ASTM A126 GR.B
18	240554-1	COVER	CAST IRON	ASTM A126 GR.B
19	45330	1/2" X 1 3/4" BOLT	STEEL/ZINC PLATED	
20	191439	1/2" HEX NUT	STEEL/ZINC PLATED	ASTM A563 GR.A
21	148790	WINDOW	MOLDED PLASTIC	
22	290148	LOWER STEM	STEEL	ASTM A500 GR.B
23	198428	SOCKET HEAD SET SCREW	STEEL	ANSI B18.3
24	290156	COUPLING INSERT	STEEL	ASTM A500 GR.B

A/c (MILLIMETER) INCH		TOLERANCES - MACHINING UNLESS OTHERWISE NOTED		THIRD ANGLE PROJECTION	
INITIAL RELEASE		BREAK EDGES MACH. .006/.016		PURCH. FINISH	
DRFT'R	MARG 9-20-07	FINISH SURFACES 125		REF. NO. SCALE	
CHK'R	ANC 9-24-07	FRACTIONS ±1/64		1:4	
APP	CJD 9-24-07	DECIMALS 2 PL ±.025 3 PL ±.010		STK. NO.	
E.O. NUMBER EO 2481		ANGLES ±1°			
Mueller Co.		MAT'L. DESCR. TWO PIECE WALL TYPE INDICATOR POST ASSEMBLY		REVISION NUMBER A A20814	
				SHEET 1 OF 1	

DWG. No. A20814

A	REMOVE ITEM #25	ANC			6-24-11
REV.	DESCRIPTION	REF.	DRFT'R	CHK'R	APP