

PART NUMBER
B24258N

44²-MRKTG

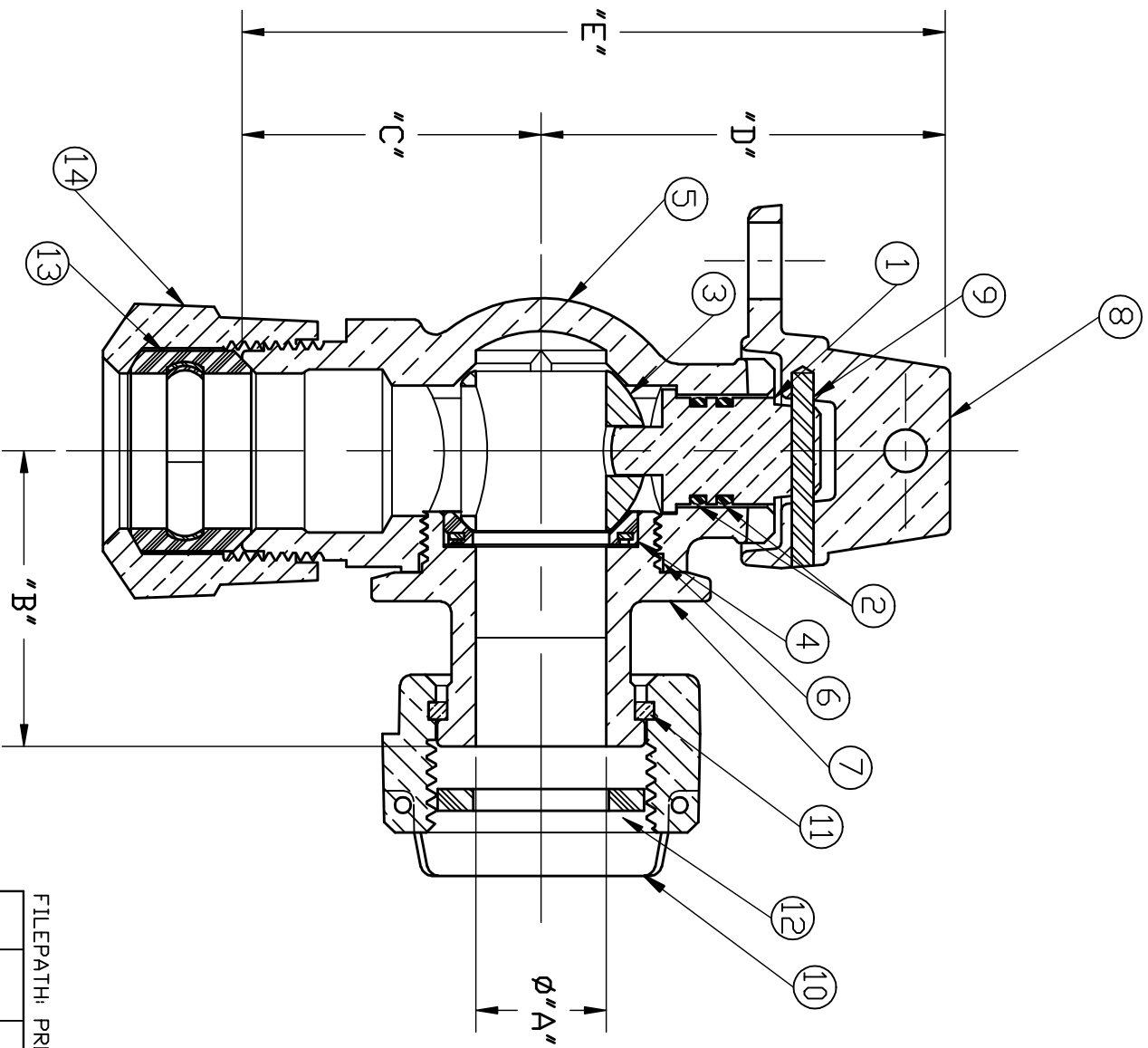

No.	QTY.	DESCRIPTION	MATERIAL
1	1	STEM	LOW LEAD BRASS
2	2	D-RING	EPDM D2000
3	1	BALL	LOW LEAD BRASS
4	1	GASKET - SEAL	NITRILE D2000
5	1	BODY	CAST LOW LEAD BRASS
6	1	D-RING	EPDM D2000
7	1	END PIECE	CAST LOW LEAD BRASS
8	1	CAP	BRASS ASTM B62 ALLDY C83600
9	1	SOLID PIN	AISI 303 STAINLESS STEEL
10	1	SADDLE NUT	BRASS ASTM B62 ALLDY C83600
11	1	SNAP RING	COPPER ALLDY CDA521
12	1	RUBBER GASKET	NITRILE D2000
13	1	CTS GSKT SUB	SBR D2000 - GSKT 410SS - BAND
14	1	CONNX NUT	CAST BRASS ASTM B62 ALLDY C83600

SIZE	øA	B	C	D	E
5/8x3/4	.625	1.696	1.719	2.323	4.042
5/8x3/4x3/4	.750	1.696	1.719	2.323	4.042
5/8x3/4x1	.750	1.696	2.125	2.323	4.448
1	1.000	1.952	2.125	2.617	4.742

FILEPATH: PROD-ENG\MUELLER\APPROVED\B24258N

REV	ECR	DESCRIPTION	DATE	BY	CHKR
PER EST NDI: DXXXX EST FIN WT = 0.0000 lbs					
DESCR: LOW LEAD MUELLER ANGLE METER BALL VALVE (110 CTS" X MTR)					
PART NUMBER: B24258N					
DRTFR	gar/vln	6/25/03			
CHKR					
ENGR					
MGR					
UNLESS OTHERWISE NOTED					
SURFACE PREPARATION: .000					
BREAK CORNER(S) --- .000					
SURFACE FINISH --- 000 RMS					
TOLERANCE(S):					
LINEAR --- ± .000					
ANGULAR --- ± 0°00'					
MATERIAL:			THIRD ANGLE PROJECTION		
STK No:			REF. No.		
BY			SCALE		
DATE			NONE		

