

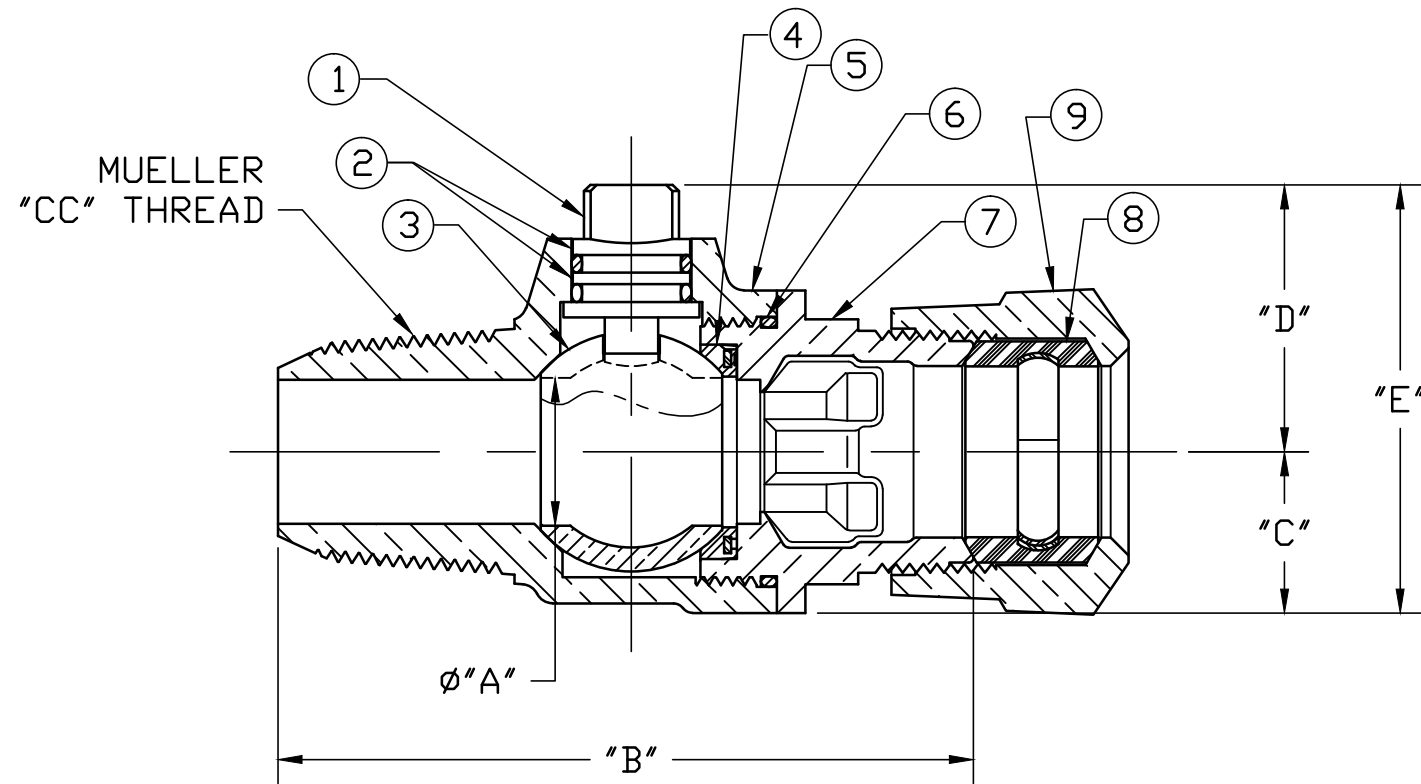

No.	DESCRIPTION	MATERIAL
1	STEM	LOW LEAD BRASS ALLOY
2	O-RING	EPDM D2000
3	BALL	LOW LEAD BRASS ALLOY
4	GASKET - SEAL	NITRILE D2000
5	BODY	CAST LOW LEAD BRASS ALLOY
6	O-RING	EPDM D2000
7	END PIECE	CAST LOW LEAD BRASS ALLOY
8	CTS GSKT SUB	SBR D2000 - GSKT 410ss - BAND
9	CONNX NUT	CAST BRASS ASTM B62 ALLOY C83600



SIZE	ØA	B	C	D	E
3/4	.750	3.621	.840	1.363	2.203
3/4x1	.750	3.855	.840	1.390	2.230
1	1.000	4.648	1.150	1.564	2.714
1x1-1/4	1.000	4.413	1.150	1.564	2.714
1-1/2	1.500	5.157	1.500	2.120	3.620
1-1/2x2	1.500	5.133	1.500	2.235	3.735
2	2.000	5.612	1.820	2.443	4.263

NOTE: ALL WETTED PARTS ARE LOW LEAD BRASS ALLOY

FILEPATH: PROD-ENG\MUELLER\ASYSUBMITTALS\B25008N

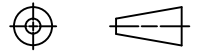
DRFTR	JGarvin	12/19/08			
CHKR					
ENGR					
MGR					
			UNLESS OTHERWISE NOTED	THIRD ANGLE PROJECTION	
			SURFACE PREPARATION:		
			BREAK CORNER(S) ---- .000		
			SURFACE FINISH -- XX RMS	REF. No.	SCALE
			TOLERANCE(S):	NONE	
			LINEAR ----- ± .000		
			ANGULAR ----- ± 0°00'		
			STK No:		
			MAT'L:		
			DESCR.		
			BALL CORPORATION VALVE	DWG NUMBER	
			LOW LEAD BRASS("CC" x 110 CTS)	B25008N	
REV	ECR	DESCRIPTION	DATE	BY	CHKR
PER EST NO: DXXXX EST FIN WT = 0.0000 lbs					

DWG NUMBER
B25008N
442-MRKTG

TITLE TO AND OWNERSHIP OF THIS ENGINEERING DATA REMAINS IN Mueller Co. NO USE IS TO BE MADE OF THIS DATA EXCEPT AS SPECIFICALLY AUTHORIZED BY Mueller Co. ASSENT ON THE PART OF THE RECIPIENT TO THESE CONDITIONS IS PRESUMED