

4 1/2" A433 & 5 1/4" A435 CENTURION UL-FM w/ TWO HOSE NOZZLES
- 200 P.S.I. W.P. - 400 P.S.I. TEST, 1997 STYLE.

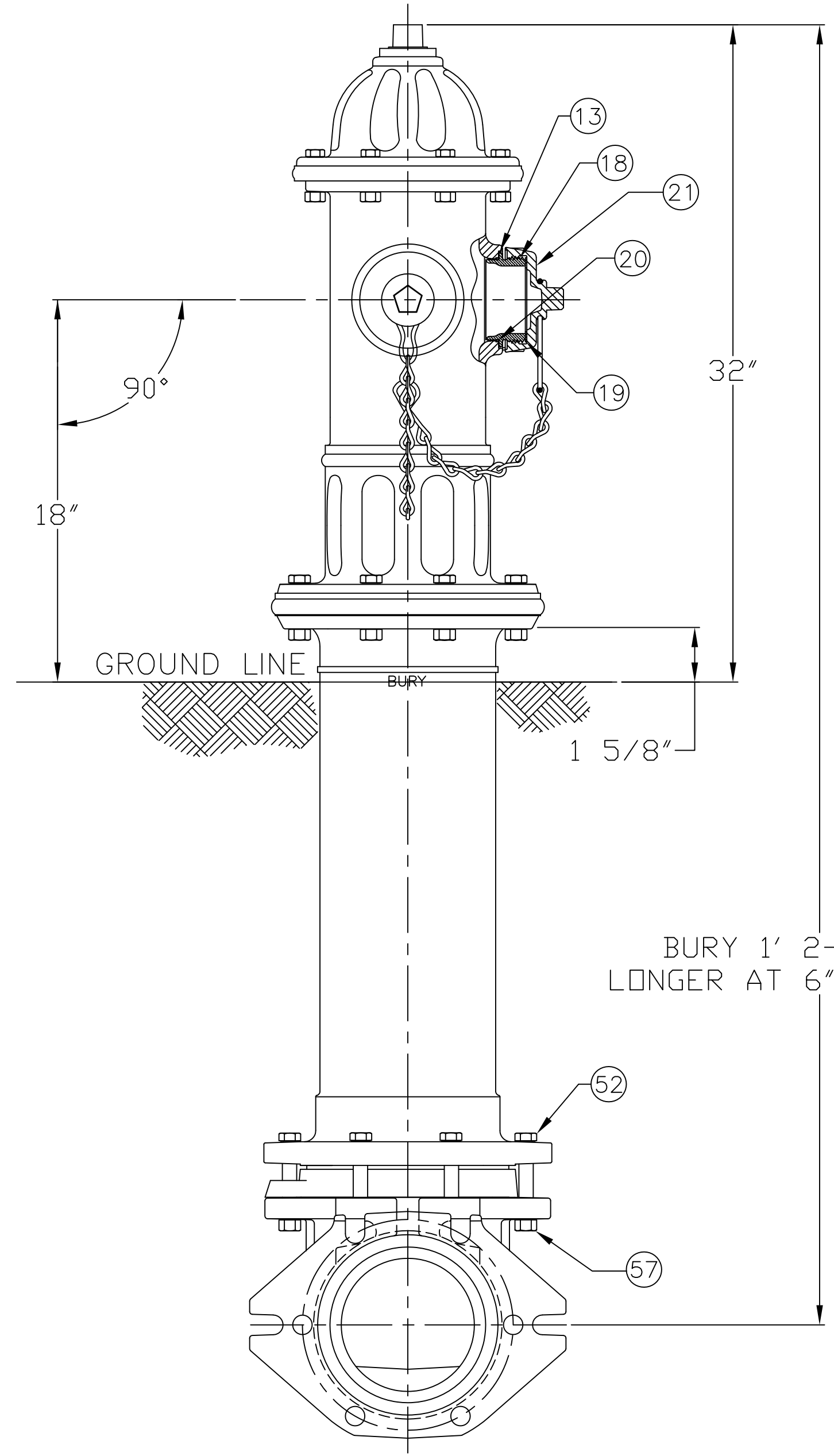

PARTS LIST				
ITEM	DESCRIPTION	REQ'D	MATERIAL	A.S.T.M.
1	OPERATING NUT	1	BRONZE	B-584 C83600
2	WIPER RING	1	RUBBER	D-2000 EPDM
3	HOLD DOWN NUT "O" RING	1	RUBBER	D-2000 BUNA N
4	HOLD DOWN NUT	1	BRONZE	B-584 C83600
5	BONNET "O" RING	1	RUBBER	D-2000 BUNA N
6	ANTI-FRICTION WASHER	1	CELCON	GR M90-04
7	OIL FILLER PLUG	1	BRASS	B-16 ALLOY 360
8	BONNET	1	CAST IRON	A-126 CLASS B
9	BONNET BOLT	8	STEEL	J429 GRADE 2
10	TOP UPPER BARREL O-RING	1	RUBBER	D-2000 BUNA N
11	UPPER STEM	1	CARBON STEEL	A-576 GR 1144T
12	STEM "O" RING (UPPER)	1	RUBBER	D-2000 BUNA N
13	NOZZLE LOCK	2	STAINLESS STEEL	A-276 305 OR 410
14	HOSE NOZZLE	1	BRONZE	B-584 C89833
15	HOSE NOZZLE CAP GASKET	1	RUBBER	D-2000 NEOPRENE
16	HOSE NOZZLE "O" RING	1	RUBBER	D-2000 BUNA N
17	HOSE NOZZLE CAP	1	CAST IRON	A-126 CLASS B
18	HOSE NOZZLE	1	BRONZE	B-584 C89833
19	HOSE NOZZLE CAP GASKET	1	RUBBER	D-2000 NEOPRENE
20	HOSE NOZZLE "O" RING	1	RUBBER	D-2000 BUNA N
21	HOSE NOZZLE CAP	1	CAST IRON	A-126 CLASS B

SEE CAT. RECORD FOR RESPECTIVE PARTS OR SUB. ASS'YS

ITEM	DESCRIPTION	REQ'D	MATERIAL	A.S.T.M.
22	CAP CHAIN	3	STEEL	ELECTRO GALV.
23	CHAIN HOOK	1	STEEL	ELECTRO GALV.
24	UPPER BARREL	1	CAST IRON	A-126 CLASS B
25	SAFETY STEM COUPLING	1	STAINLESS STEEL	A-890 1.5% SILICON MAX
26	SAFETY FLANGE BOLT	8	STEEL	J429 GRADE 2
27	BOTTOM UPPER BARREL O-RING	1	RUBBER	D-2000 BUNA N
28	SAFETY FLANGE	1	CAST IRON	A-126 CLASS B
29	COTTER PIN	2	STAINLESS STEEL	A-276 302
30	CLEVIS PIN	2	STAINLESS STEEL	A-276 305
31	LOWER STEM	1	CARBON STEEL	A-576 GR 1144T
32	LOWER BARREL	1	CAST IRON	A-126 CLASS B
33	STEM PIN	1	STAINLESS STEEL	A-276 302
34	DRAIN VALVE FACING	2	H.D. POLYETHYLENE	LS 5660-00
35	DRAIN VALVE FACING SCREW	4	STAINLESS STEEL	A-276 302
36	UPPER VALVE PLATE	1	BRONZE	B-584 C89833
37	BOTTOM SEAT "O" RING	1	RUBBER	D-2000 BUNA N
38	DRAIN RING HOUSING	1	CAST IRON	A-126 CLASS B
39	SEAT RING	1	BRONZE	B-584 C89833
40	DRAIN RING	1	BRONZE	B-584 ALLOY 844
41	MAIN VALVE	1	RUBBER	D-2000 NATURAL
42	LOWER VALVE PLATE	1	CAST IRON	A-126 CLASS B
43	LOCK WASHER	1	STAINLESS STEEL	A-276 302

ITEM	DESCRIPTION	REQ'D	MATERIAL	A.S.T.M.
44	VALVE NUT	1	CAST IRON	A-126 CLASS B
45	VALVE NUT SEAL	1	RUBBER	D-2000 NITRILE
46	BONNET NUT	8	STEEL	A-563 GRADE B
47	STEM O-RING	2	RUBBER	D-2000 BUNA N
48	SAFETY FLANGE NUT	8	STEEL	A-563 GRADE B
49	DRAIN RING HOUSING O-RING	1	RUBBER	D-2000 BUNA N
50	SLEEVE	1	COPPER	B-75 ALLOY 122
51	UPPER STEM PIN	1	STAINLESS STEEL	A-276 302
52	HEX BOLT	6	STEEL	J429 GRADE 2
53	SHOE	1	DUCTILE IRON	A-536 65-45-12
54	PIPE GLAND	1	CAST IRON	A-126 CLASS B
55	HEX BOLT	2	STEEL	A-307 ELECTROGALV. GR. B
56	"O" RING	1	RUBBER	D-2000 BUNA N
57	HEX NUT	6	STEEL	A-563 GRADE B
*58	PIPE PLUG	1	CAST IRON	A-126 CLASS B
59				
60				
61				
62				

* OPTIONAL



UPPER BARREL MARKINGS

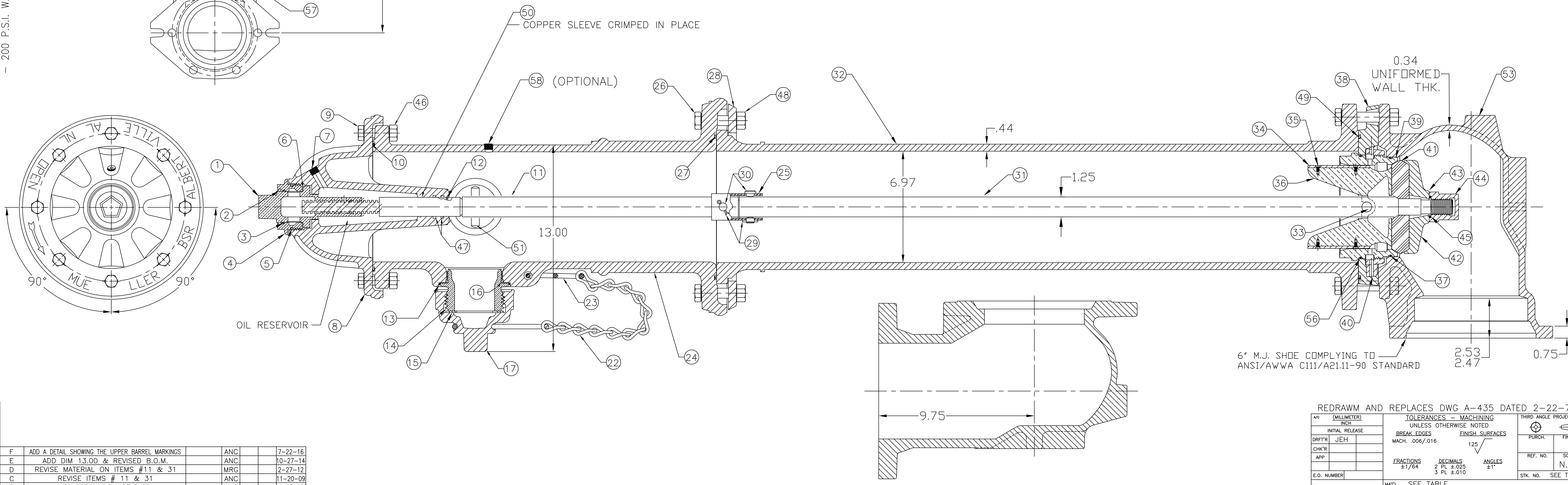

REV.	DESCRIPTION	REF.	DRFTR	CHKR	APP	DATE
F	ADD A DETAIL SHOWING THE UPPER BARREL MARKINGS		ANC			7-22-16
E	ADD DIM 13.00 & REVISED B.O.M.		ANC			10-27-14
D	REVISE MATERIAL ON ITEMS #11 & 31		MRG			2-27-12
C	REVISE ITEMS # 11 & 31		ANC			11-20-09
B	ADD OPTIONAL FLANGE SHOE		ANC			4-25-08
A	ADDED A433 HYDRANT AND REVISED ITEMS 13-17		ANC			5-2-07

REDRAWN AND REPLACES DWG A-435 DATED 2-22-79

APR (MILLIMETER)	TOLERANCES - MACHINING	THIRD ANGLE PROJECTION
INCH	UNLESS OTHERWISE NOTED	
INITIAL RELEASE	BREAK EDGES	FINISH SURFACES
DRFTR JEH	MACH. .006/.016	125
CHK'R	FRACTIONS ±1/64	DECIMALS 2 PL ±.025
APP		3 PL ±.010
E.O. NUMBER	ANGLES ±1°	
	MAT'L SEE TABLE	REVISION NUMBER
	DESCR 4 1/2" A433 & 5 1/4" A435	FH-111
	CENTURION W/TWO HOSE NOZZLES	SHEET 1 OF 1

Mueller Co.

DWG. FH-111