

4 1/2" A420 & 5 1/4" A422 SUPER CENTURION "200" W/ TWO HOSE NOZZLES - 1997 STYLE

DWG. FH 132

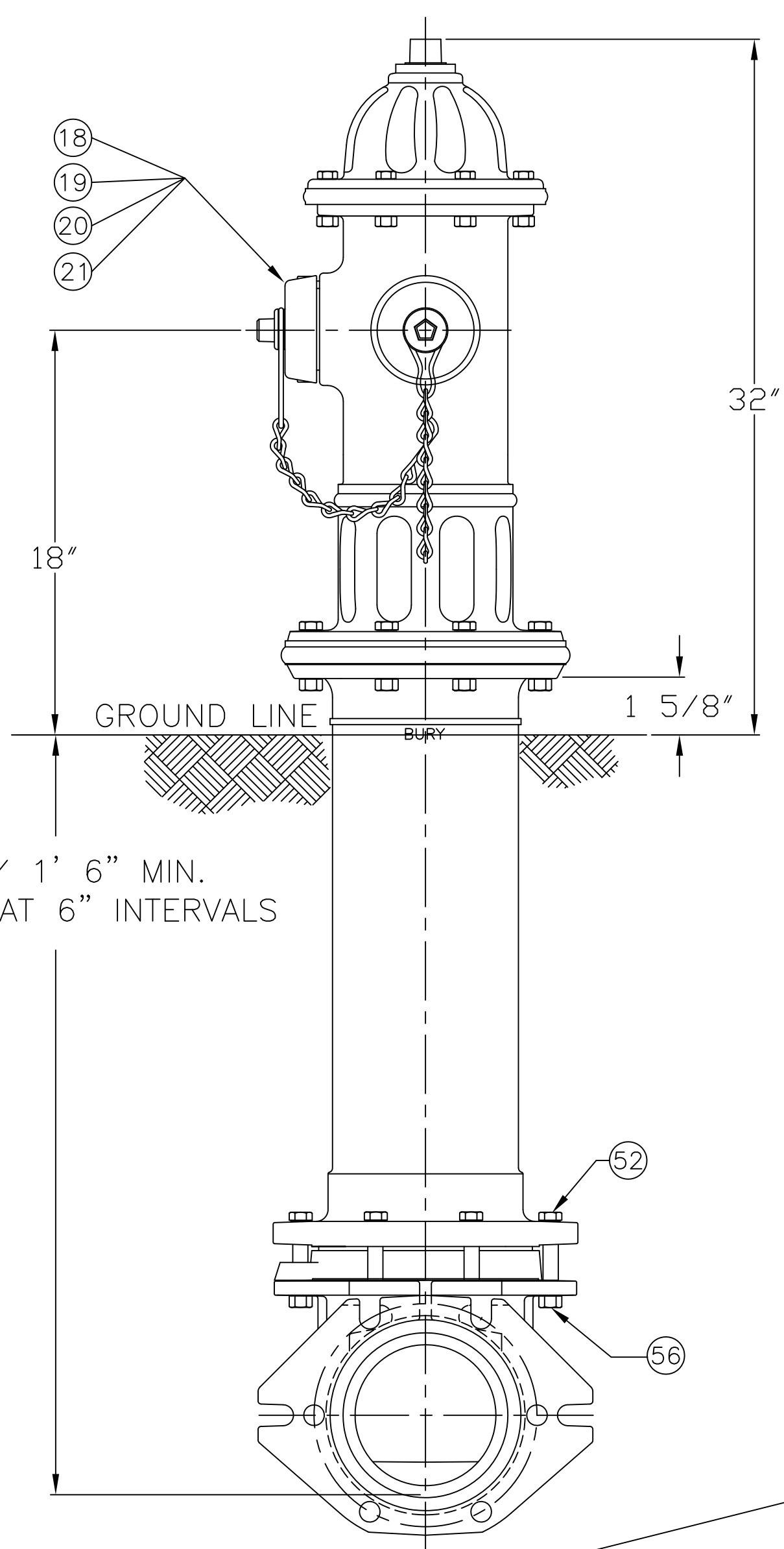

PARTS LIST				
ITEM	DESCRIPTION	REQ'D	MATERIAL	A.S.T.M.
1	OPERATING NUT	1	BRONZE	B-584 ALLOY 844
2	WIPER RING	1	RUBBER	D-2000 EPDM
3	HOLD DOWN NUT O-RING	1	RUBBER	D-2000 BUNA N
4	HOLD DOWN NUT	1	BRONZE	B-584 ALLOY 844
5	BONNET O-RING	1	RUBBER	D-2000 BUNA N
6	ANTI-FRICTION WASHER	1	CELCON	GRADE M90-04
7	OIL FILLER PLUG	1	BRASS	B-16 ALLOY 360
8	BONNET	1	CAST IRON	A-126 CLASS B
9	HEX BOLT	8	STEEL	A-307 ELECTROGALV. GR. B
10	BONNET GASKET	1	CELLULOSE	
11	UPPER STEM	1	CARBON STEEL	A-576 GR 1144T
12	STEM O-RING	1	RUBBER	D-2000 BUNA N
13	NOZZLE LOCK	3	STAINLESS STEEL	A-276 305 OR 410
14	HOSE NOZZLE	1	BRONZE	B-584 ALLOY 844
15	HOSE NOZZLE CAP GASKET	1	RUBBER	D-2000 NEOPRENE
16	HOSE NOZZLE O-RING	1	RUBBER	D-2000 BUNA N
17	HOSE NOZZLE CAP	1	CAST IRON	A-126 CLASS B
18	HOSE NOZZLE	2	BRONZE	B-584 ALLOY 844
19	HOSE NOZZLE CAP GASKET	2	RUBBER	D-2000 NEOPRENE
20	HOSE NOZZLE O-RING	2	RUBBER	D-2000 BUNA N
21	HOSE NOZZLE CAP	2	CAST IRON	A-126 CLASS B

ITEM	DESCRIPTION	REQ'D	MATERIAL	A.S.T.M.
22	CAP CHAIN	3	STEEL	ELECTRO GALV.
23	CHAIN HOOK	1	STEEL	ELECTRO GALV.
24	UPPER BARREL	1	CAST IRON	A-126 CLASS B
25	SAFETY STEM COUPLING	1	STAINLESS STEEL	A-890 1.5% SILICON MAX.
26	SAFETY FLANGE BOLT	8	STEEL	A-307 ELECTROGALV. GR. B
27	SAFETY FLANGE GASKET	1		
28	SAFETY FLANGE	1	CAST IRON	A-126 CLASS B
29	COTTER PIN	2	STAINLESS STEEL	A-276 302
30	CLEVIS PIN	2	STAINLESS STEEL	A-276 305
31	LOWER STEM	1	CARBON STEEL	A-576 GR 1144T
32	LOWER BARREL	1	CAST IRON	A-126 CLASS B
33	STEM PIN	1	STAINLESS STEEL	A-276 302
34	DRAIN VALVE FACING	2	H.D. POLYETHYLENE	LS 5660-00
35	DRAIN VALVE FACING SCREW	4	STAINLESS STEEL	A-276 302
36	UPPER VALVE PLATE	1	BRONZE	B-584 ALLOY 844
37	BOTTOM SEAT O-RING	1	RUBBER	D-2000 BUNA N
38	DRAIN RING	1	BRONZE	B-584 ALLOY 844
39	SEAT RING	1	BRONZE	B-584 ALLOY 844
40	DRAIN RING HOUSING	1	CAST IRON	A-126 CLASS B
41	MAIN VALVE	1	RUBBER	D-2000 NATURAL
42	LOWER VALVE PLATE	1	CAST IRON	A-126 CLASS B
43	LOCK WASHER	1	STAINLESS STEEL	A-276 302

ITEM	DESCRIPTION	REQ'D	MATERIAL	A.S.T.M.
44	VALVE NUT	1	CAST IRON	A-126 CLASS B
45	VALVE NUT SEAL	1	RUBBER	NITRILE
46	HEX NUT	8	STEEL	ELECTRO. GALV.
47	STEM O-RING	2	RUBBER	D-2000 BUNA N
48	SAFETY FLANGE NUT	8	STEEL	ELECTRO. GALV.
49	DRAIN RING HOUSING O-RING	1	RUBBER	D-2000 BUNA N
50	SLEEVE	1	COPPER	B-75 ALLOY 122
51	UPPER STEM PIN	1	STAINLESS STEEL	A-276 302
52	HEX BOLT	6	STEEL	A-307 ELECTROGALV. GR. B
53	SHOE	1	DUCTILE IRON	A536 65-45-12
* 54	PIPE GLAND	1	CAST IRON	A-126 CLASS B
* 55	TOP SEAT O-RING	1	RUBBER	D-2000 BUNA N
56	HEX NUT	6	STEEL	A-307 ELECTROGALV. GR. B
* 57	MECH. JOINT GASKET	1	RUBBER	D-2000 NATURAL
* 58	T-HEAD BOLT	6	STEEL	A-242 TYPE 1
* 59	HEX NUT	6	STEEL	A-242 TYPE 1

SEE CAT. RECORD FOR RESPECTIVE PARTS OR SUB. ASS'YS

\* NOT SHOWN

NOTE: SIZE AND STYLE OF OPERATING NUT, SHOE SIZE, AND THREADING OF NOZZLES IS PER CUSTOMER SPECS.

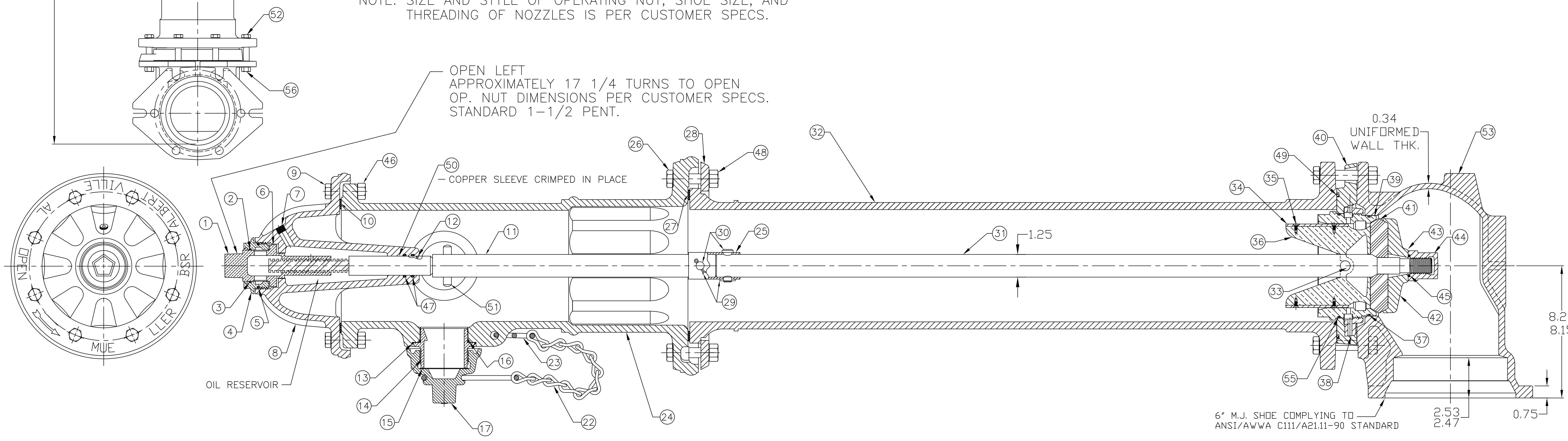

REV.	DESCRIPTION	REF.	DATE
B	REVISE ITEMS #11 & 31	MRG	2-27-12
A	REVISE ITEMS # 11 & 31	ANC	11-20-09

DRFT'R SMC 4-27-05 CHK'R JMG 4-27-05 APP E.O. NUMBER	<b>TOLERANCES - MACHINING</b> UNLESS OTHERWISE NOTED BREAK EDGES FINISH SURFACES MACH. .006/.016 125 FRACTIONS ±1/64 DECIMALS 2 PL. ±.025 3 PL. ±.005 ANGLES ±1°	THIRD ANGLE PROJECTION PURCH. FINISH REF. NO. SCALE N.T.S. STK. NO.
MAT'L SEE TABLE DESCR. 4 1/2" A420 & 5 1/4" A422 SUPER CENTURION "200" W/ TWO HOSE NOZZLES 1997 STYLE		REVISION B NUMBER FH 132 SHEET 1 OF 1