

4 1/2" A461 SUPER CENTURION "250" W/ TWO HOSE NOZZLES
& ONE PUMPER NOZZLE - 250 P.S.I. W.P. - 500 P.S.I. TEST, 1997 STYLE.

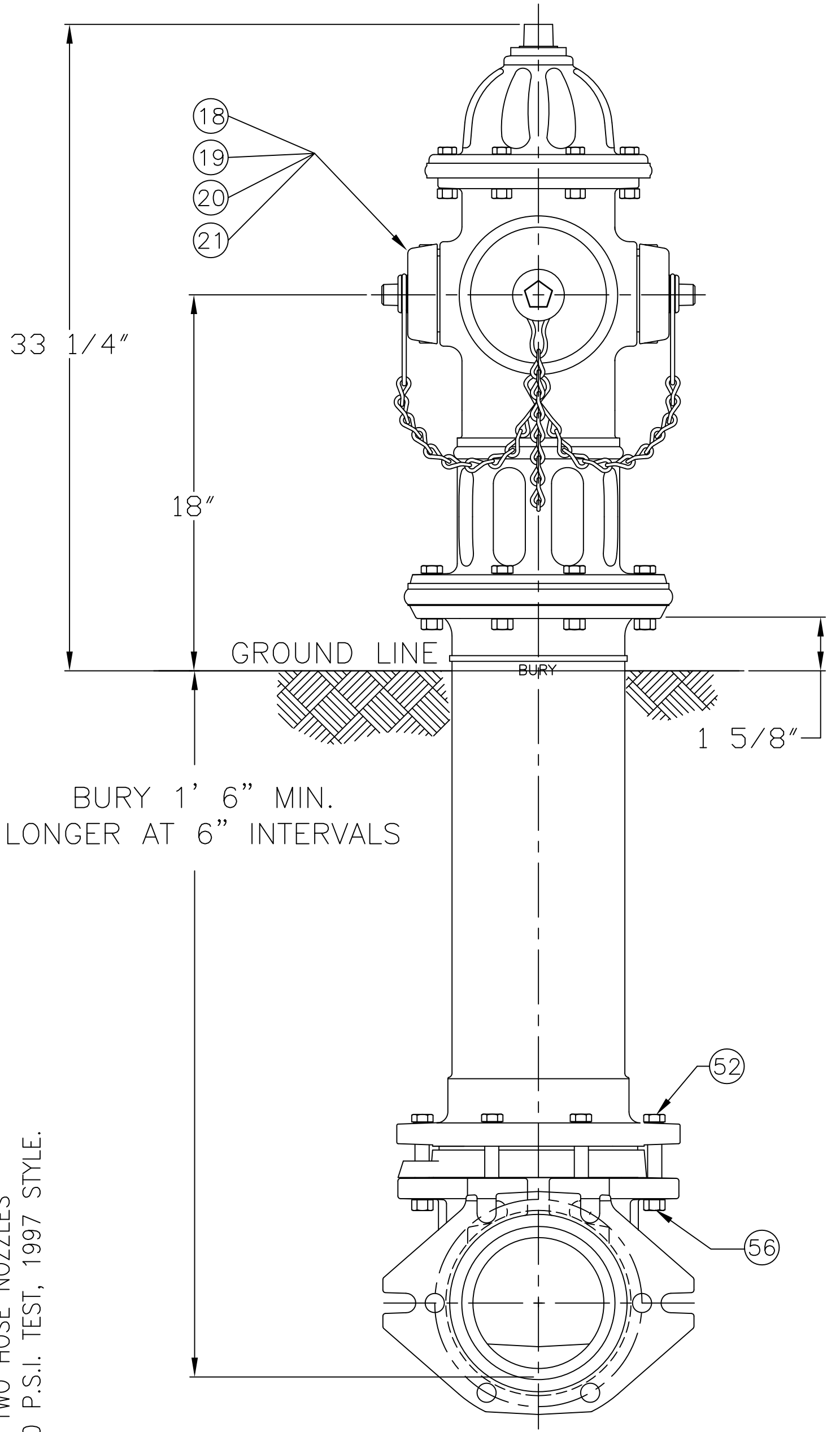

PARTS LIST				
ITEM	DESCRIPTION	REQ'D	MATERIAL	A.S.T.M.
1	OPERATING NUT	1	BRONZE	B-62 ALLOY C83600
2	WIPER RING	1	RUBBER	D-2000 R 33
3	HOLD DOWN NUT "O" RING	1	RUBBER	D-2000 BUNA N
4	HOLD DOWN NUT	1	BRONZE	B-62 ALLOY C83600
5	BONNET "O" RING	1	RUBBER	D-2000 BUNA N
6	ANTI-FRICTION WASHER	1	PLASTIC	CELCON
7	OIL FILLER PLUG	1	BRASS	B-16 ALLOY 360
8	BONNET	1	CAST IRON	A-126 CLASS B
9	BONNET BOLT	8	STEEL	A-307 ELECTROGALV. GR. B
10	TOP UPPER BARREL O-RING	1	RUBBER	D-2000 BUNA N
11	UPPER STEM	1	CARBON STEEL	A-576 GR 1144T
12	STEM "O" RING (UPPER)	1	RUBBER	D-2000 BUNA N
13	NOZZLE LOCK	3	STAINLESS STEEL	A-276 305 OR 410
14	PUMPER NOZZLE	1	BISMUTH BRASS	B-584 ALLOY C89833
15	PUMPER NOZZLE CAP GASKET	1	RUBBER	D-2000 R 51
16	PUMPER NOZZLE "O" RING	1	RUBBER	D-2000 BUNA N
17	PUMPER NOZZLE CAP	1	CAST IRON	A-126 CLASS B
18	HOSE NOZZLE	2	BISMUTH BRASS	B-584 ALLOY C89833
19	HOSE NOZZLE CAP GASKET	2	RUBBER	D-2000 R 51
20	HOSE NOZZLE "O" RING	2	RUBBER	D-2000 BUNA N
21	HOSE NOZZLE CAP	2	CAST IRON	A-126 CLASS B

SEE CAT. RECORD FOR RESPECTIVE PARTS OR SUB. ASS'YS

ITEM	DESCRIPTION	REQ'D	MATERIAL	A.S.T.M.
22	CHAINS	3	STEEL	
23	CHAIN CONNECTOR HOOK	1	STEEL	
24	UPPER BARREL	1	CAST IRON	A-126 CLASS B
25	SAFETY STEM COUPLING	1	STAINLESS STEEL	A-890 1.5% SILICON MAX.
26	SAFETY FLANGE BOLT	8	STEEL	A-307 ELECTROGALV. GR. B
27	BOTTOM UPPER BARREL O-RING	1	RUBBER	D-2000 BUNA N
28	SAFETY FLANGE	1	CAST IRON	A-126 CLASS B
29	COTTER PIN	2	STAINLESS STEEL	A-276 302
30	CLEVIS PIN	2	STAINLESS STEEL	A-276 305
31	LOWER STEM	1	CARBON STEEL	A-576 GR 1144T
32	LOWER BARREL	1	DUCTILE IRON	A-536 CLASS 64-45-12
33	STEM PIN	1	STAINLESS STEEL	A-276 302
34	DRAIN VALVE FACING	2	PLASTIC	H.D. POLYETHYLENE
35	DRAIN VALVE FACING SCREW	4	STAINLESS STEEL	A-276 302
36	UPPER VALVE PLATE	1	BISMUTH BRASS	B-584 ALLOY C89833
37	BOTTOM SEAT "O" RING	1	RUBBER	D-2000 BUNA N
38	DRAIN RING	1	BRONZE	B-62 ALLOY C83600
39	SEAT RING	1	BISMUTH BRASS	B-584 ALLOY C89833
40	DRAIN RING HOUSING	1	CAST IRON	A-126 CLASS B
41	MAIN VALVE	1	RUBBER	D-2000 R-44
42	LOWER VALVE PLATE	1	CAST IRON	A-126 CLASS B
43	LOCK WASHER	1	STAINLESS STEEL	A-276 302

ITEM	DESCRIPTION	REQ'D	MATERIAL	A.S.T.M.
44	VALVE NUT	1	CAST IRON	A-126 CLASS B
45	VALVE NUT SEAL	1	RUBBER	R-32
46	BONNET NUT	8	STEEL	ELECTRO. GALV.
47	STEM O-RING	2	RUBBER	D-2000 BUNA N
48	SAFETY FLANGE NUT	8	STEEL	ELECTRO. GALV.
49	DRAIN RING HOUSING O-RING	1	RUBBER	D-2000 BUNA N
50	SLEEVE	1	COPPER	B-75 ALLOY 122
51	UPPER STEM PIN	1	STAINLESS STEEL	A-276 302
52	HEX BOLT	6	STEEL	A-307 ELECTROGALV. GR. B
53	SHOE	1	DUCTILE IRON	A-536 CLASS 64-45-12
54	PIPE GLAND	1	CAST IRON	A-126 CLASS B
55	TOP SEAT O-RING	1	RUBBER	D-2000 BUNA N
56	HEX NUT	6	STEEL	A-307 ELECTROGALV. GR. B
57	STOP NUT	1	DUCTILE IRON	A-395
* 58	MECH. JOINT GASKET	1	RUBBER	D-2000 R-42
* 59	T-HEAD BOLT	6	STEEL	A-242 TYPE 1
* 60	HEX NUT	6	STEEL	A-242 TYPE 1

* NOT SHOWN

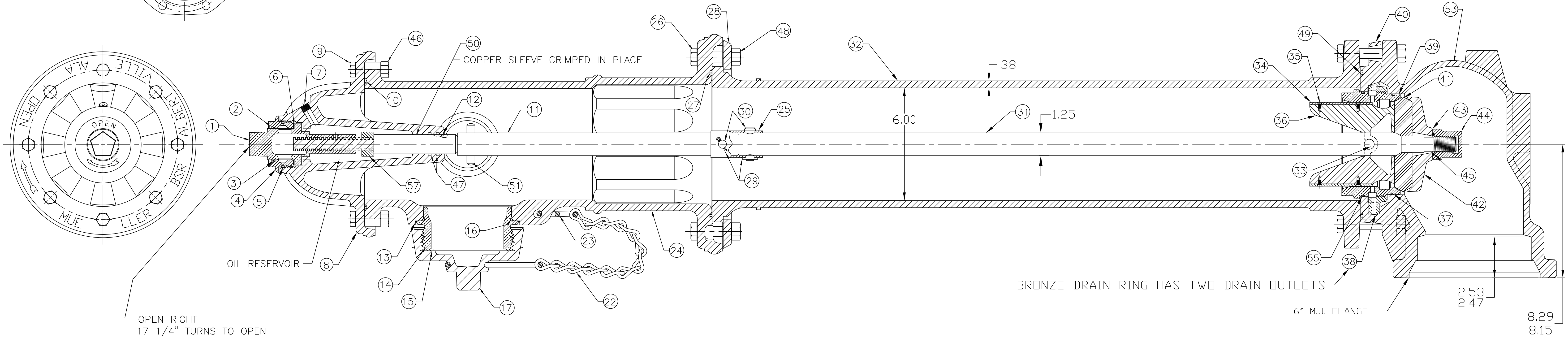

DWG. FH 157

REV.	DESCRIPTION	REF.	DRFTR	CHKR	APP	DATE
C	REVISE MATERIAL ON ITEMS #14,18,36,39		ANC			11-1-13
B	REVISE ITEMS #11 & 31		MRG			3-13-12
A	REVISE ITEMS # 11 & 31		ANC			11-30-09

INCH INITIAL RELEASE DRFTR ANC 4-02-07 CHK'R APP CJD 4-02-07 E.O. NUMBER	TOLERANCES - MACHINING UNLESS OTHERWISE NOTED BREAK EDGES MACH. .006/.016 FINISH SURFACES 125 FRACTIONS ±1/64 DECIMALS 2 PL ±.025 3 PL ±.010 ANGLES ±1°	THIRD ANGLE PROJECTION PURCH. FINISH REF. NO. SCALE N.T.S. STK. NO. SEE TABLE
MAT'L SEE TABLE DESCR. 4 1/2" SUPER CENTURION "250" W/ TWO HOSE NOZZLES & ONE PUMPER NOZZLE A461		REVISION NUMBER C FH 157 SHEET 1 OF 1