

4-1/2" A424 SUPER CENTURION "200" W/ ONE PUMPER NOZZLE
200 P.S.I. W.P.- 400 P.S.I. TEST, 1997 STYLE.

DWG. FH 8

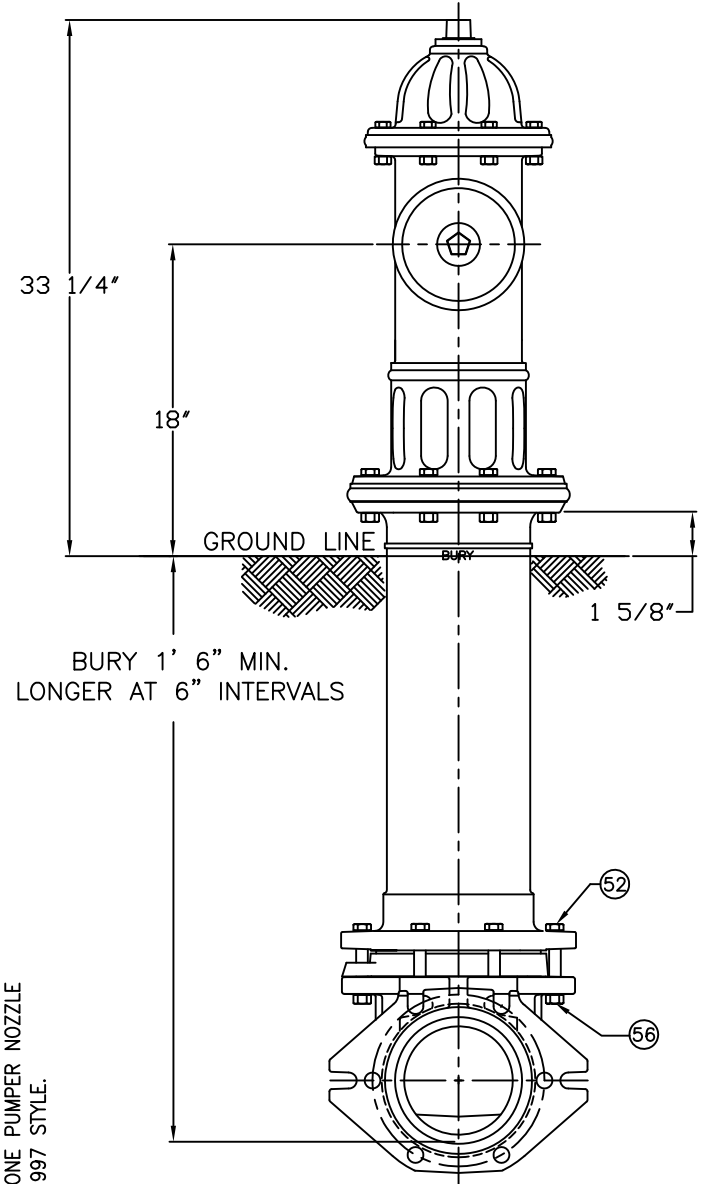

PARTS LIST				
ITEM	DESCRIPTION	REQ'D	MATERIAL	A.S.T.M.
1	OPERATING NUT	1	BRONZE	B-584
2	WIPER RING	1	RUBBER	D-2000
3	HOLD DOWN NUT "O" RING	1	RUBBER	D-2000
4	HOLD DOWN NUT	1	BRONZE	B-584
5	BONNET "O" RING	1	RUBBER	D-2000
6	ANTI-FRICTION WASHER	1	PLASTIC	
7	OIL FILLER PLUG	1	BRASS	B-16
8	BONNET	1	CAST IRON	A-126
9	BONNET BOLT	8	STEEL	A-307
10	TOP UPPER BARREL O-RING	1	RUBBER	D-2000
11	UPPER STEM	1	CARBON STEEL	A-576
12	STEM "O" RING (UPPER)	1	RUBBER	D-2000
13	NOZZLE LOCK	3	STAINLESS STEEL	A-276
14	PUMPER NOZZLE	1	BRONZE	B-584
15	PUMPER NOZZLE CAP GASKET	1	RUBBER	D-2000
16	PUMPER NOZZLE "O" RING	1	RUBBER	D-2000
17	PUMPER NOZZLE CAP	1	CAST IRON	A-126
18				
19				
20				
21				

ITEM	DESCRIPTION	REQ'D	MATERIAL	A.S.T.M.
22	CHAINS	3	STEEL	
23	CHAIN CONNECTOR HOOK	1	STEEL	
24	UPPER BARREL	1	CAST IRON	A-126
25	SAFETY STEM COUPLING	1	STAINLESS STEEL	A-890
26	SAFETY FLANGE BOLT	8	STEEL	A-307
27	BOTTOM UPPER BARREL O-RING	1	RUBBER	D-2000
28	SAFETY FLANGE	1	CAST IRON	A-126
29	COTTER PIN	2	STAINLESS STEEL	A-276
30	CLEVIS PIN	2	STAINLESS STEEL	A-276
31	LOWER STEM	1	CARBON STEEL	A-576
32	LOWER BARREL	1	CAST IRON	A-126
33	STEM PIN	1	STAINLESS STEEL	A-276
34	DRAIN VALVE FACING	2	PLASTIC	
35	DRAIN VALVE FACING SCREW	4	STAINLESS STEEL	A-276
36	UPPER VALVE PLATE	1	BRONZE	B-584
37	BOTTOM SEAT "O" RING	1	RUBBER	D-2000
38	DRAIN RING	1	BRONZE	B-584
39	SEAT RING	1	BRONZE	B-584
40	DRAIN RING HOUSING	1	CAST IRON	A-126
41	MAIN VALVE	1	RUBBER	D-2000
42	LOWER VALVE PLATE	1	CAST IRON	A-126
43	LOCK WASHER	1	STAINLESS STEEL	A-276

ITEM	DESCRIPTION	REQ'D	MATERIAL	A.S.T.M.
44	VALVE NUT	1	CAST IRON	A-126
45	VALVE NUT SEAL	1	RUBBER	
46	BONNET NUT	8	STEEL	
47	STEM O-RING	2	RUBBER	D-2000
48	SAFETY FLANGE NUT	8	STEEL	
49	DRAIN RING HOUSING O-RING	1	RUBBER	D-2000
50	SLEEVE	1	COPPER	B-75
51	UPPER STEM PIN	1	STAINLESS STEEL	A-276
52	HEX BOLT	6	STEEL	A-307
53	SHOE	1	CAST IRON	A-126
54	PIPE GLAND	1	CAST IRON	A-126
55	TOP SEAT O-RING	1	RUBBER	D-2000
56	HEX NUT	6	STEEL	A-307
* 58	MECH. JOINT GASKET	1	RUBBER	D-2000
* 59	T-HEAD BOLT	6	STEEL	A-242
* 60	HEX NUT	6	STEEL	A-242

* NOT SHOWN SEE CAT. RECORD FOR RESPECTIVE PARTS OR SUB. ASS'YS

OPEN LEFT APPROXIMATELY 17 1/4" TURNS TO OPEN OP. NUT DIMENSIONS PER CUSTOMER SPECS. STANDARD 1-1/2 PENT.

NOTE: SIZE AND STYLE OF OPERATING NUT, SHOE SIZE, AND THREADING OF NOZZLES IS PER CUSTOMER SPECS.

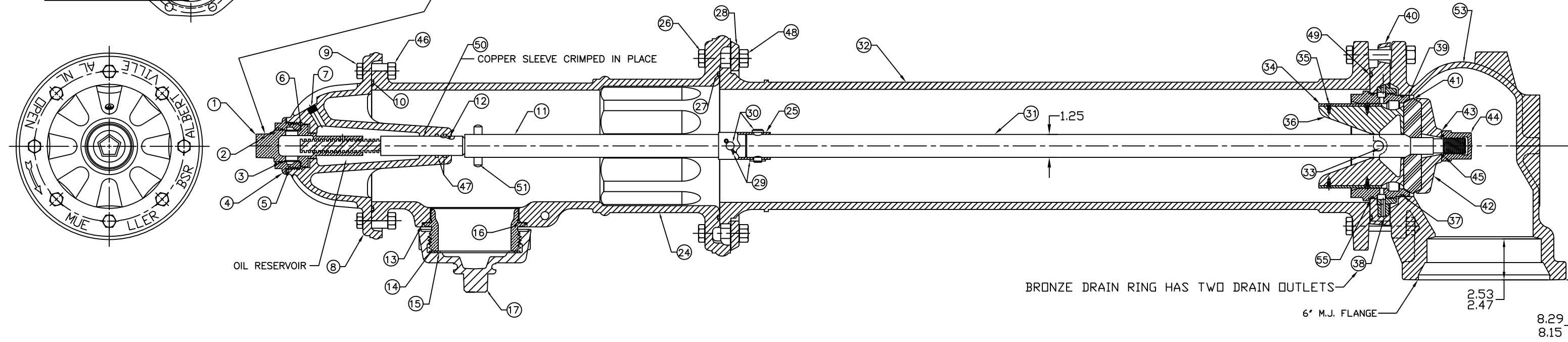

REV.	DESCRIPTION	REF.	DATE
C	REVISED ITEMS 1, 4, 14, 36, & 39		11-7-13
B	REVISED MATERIAL ON ITEMS #11 & 31		2-23-12
A	REVISED MATERIAL ON ITEMS #11 & 31		11-6-08

(MILLIMETER) INCH INITIAL RELEASE DWG/CHK APP E.O. NUMBER	TOLERANCES - MACHINING UNLESS OTHERWISE NOTED BREAK EDGES MACH. .006/.016 FINISH SURFACES 125 ANGLES ±1°	THIRD ANGLE PROJECTION PURCH. FINISH REF. NO. SCALE N.T.S. STK. NO. SEE TABLE
MAT'L SEE TABLE DESCR. 4 1/2" A-424 SUPER CENTURION "200" W/ ONE PUMPER NOZZLE 1997 STYLE.		REVISION C DWG. NO. FH 8 SHEET 1 OF 1