

No.	DESCRIPTION	MATERIAL	No.	DESCRIPTION	MATERIAL
1	KEY CAP	CAST BRASS ASTM B62 ALLOY C83600	7	SADDLE NUT	CAST BRASS ASTM B62 ALLOY C83600
2	PIN	BRASS ASTM B16 ALLOY C36000	8	SNAP RING	PHOS BRONZE
3	SPRING WASHER	PHOS BRONZE	9	RUBBER GASKET	NITRILE ASTM D2000
4	O-RING	EPDM ASTM D2000	10	PJ GASKET	BUNA-N ASTM D2000
5	KEY	CAST LOW LEAD BRASS ALLOY	11	PJ WASHER	POLYPROPYLENE
6	BODY	CAST LOW LEAD BRASS ALLOY	12	COMPRESSION RING	BRASS ASTM B505 ALLOY C83600
			13	COMPRESSION NUT	CAST BRASS ASTM B62 ALLOY C83600

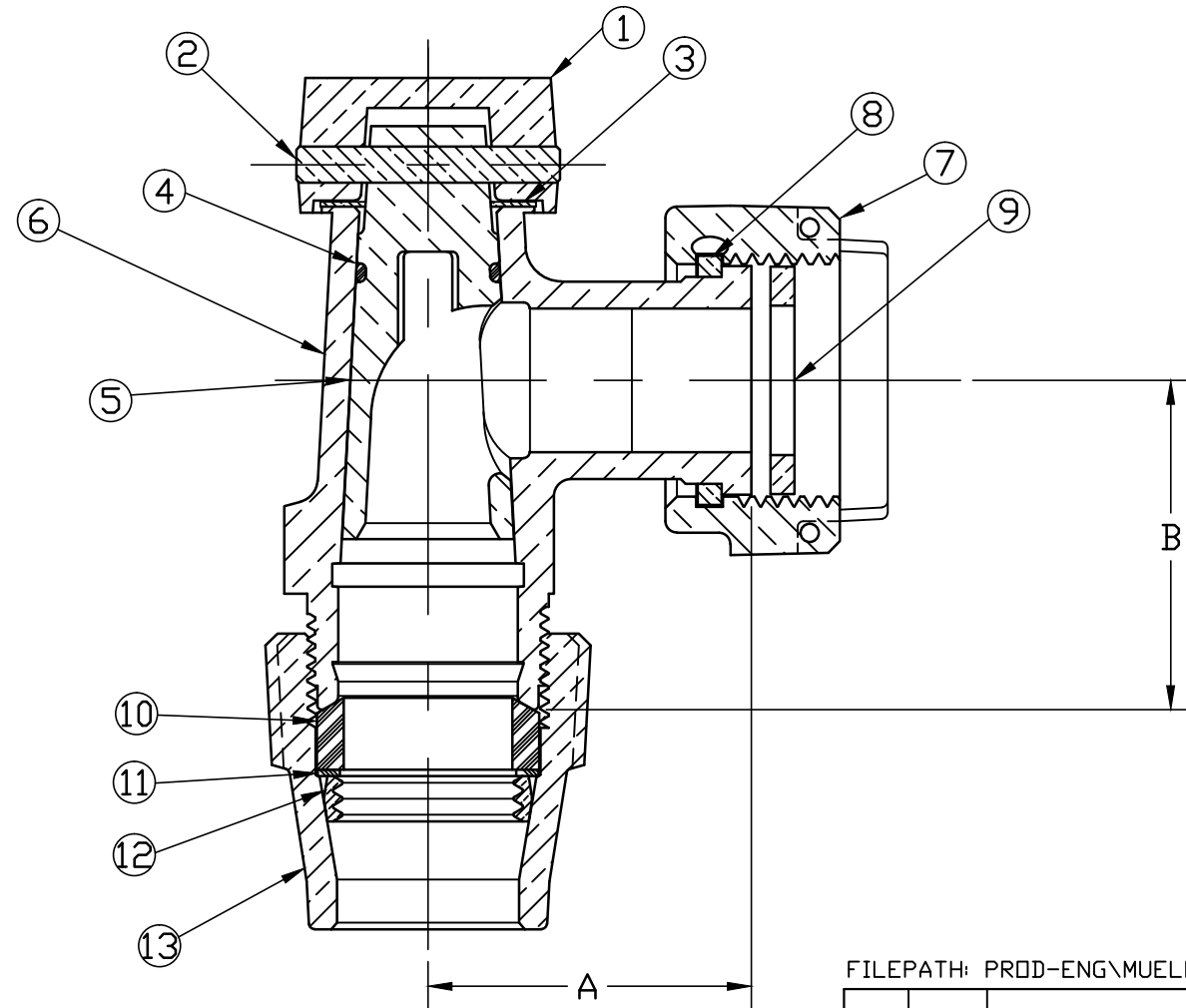

METER CONNX SIZE	A	B
5/8 x 3/4	1-11/16"	1-23/32"
5/8 x 3/4 X 3/4	1-11/16"	1-23/32"
5/8 x 3/4 X 1	1-11/16"	1-31/32"
1	1-15/16"	2-1/8"

ALL WETTED PART ARE LOW LEAD BRASS ALLOY

FILEPATH: PROD-ENG\MUELLER\ASYSUBMITTALS\G14258N

DRFTR	RWB	3/25/13	Mueller Co.		
CHKR					
ENGR					
MGR					
			UNLESS OTHERWISE NOTED	THIRD ANGLE PROJECTION	
			SURFACE PREPARATION:		
			BREAK CORNER(S) ----- .000		
			SURFACE FINISH -- XX RMS	REF. No.	
			TOLERANCE(S):	SCALE	
			LINEAR ----- ± .000	FULL	
			ANGULAR ----- ± 0°00'		
			STK No:		
			MAT'L:		
			DESCR.		
			LLB ANGLE METER STOP	DWG NUMBER	
			GRIP x MTR	G14258N	
REV	ECR	DESCRIPTION	DATE	BY	CHKR
PER EST NO: DXXXX EST FIN WT = 0.0000 lbs					

DWG NUMBER
G14258N
442-MRKTG

TITLE TO AND OWNERSHIP OF THIS ENGINEERING DATA REMAINS IN Mueller Co. NO USE IS TO BE MADE OF THIS DATA EXCEPT AS SPECIFICALLY AUTHORIZED BY Mueller Co. ASSENT ON THE PART OF THE RECIPIENT TO THESE CONDITIONS IS PRESUMED