

No.	DESCRIPTION	MATERIAL
1	SPUD	CAST LOW LEAD BRASS ALLOY
2	PJ GASKET	BUNA-N ASTM D2000
3	PJ WASHER	POLYPROPYLENE
4	COMPRESSION RING	BRASS ASTM B505 ALLOY C83600
5	COMPRESSION NUT	CAST BRASS ASTM B62 ALLOY C83600

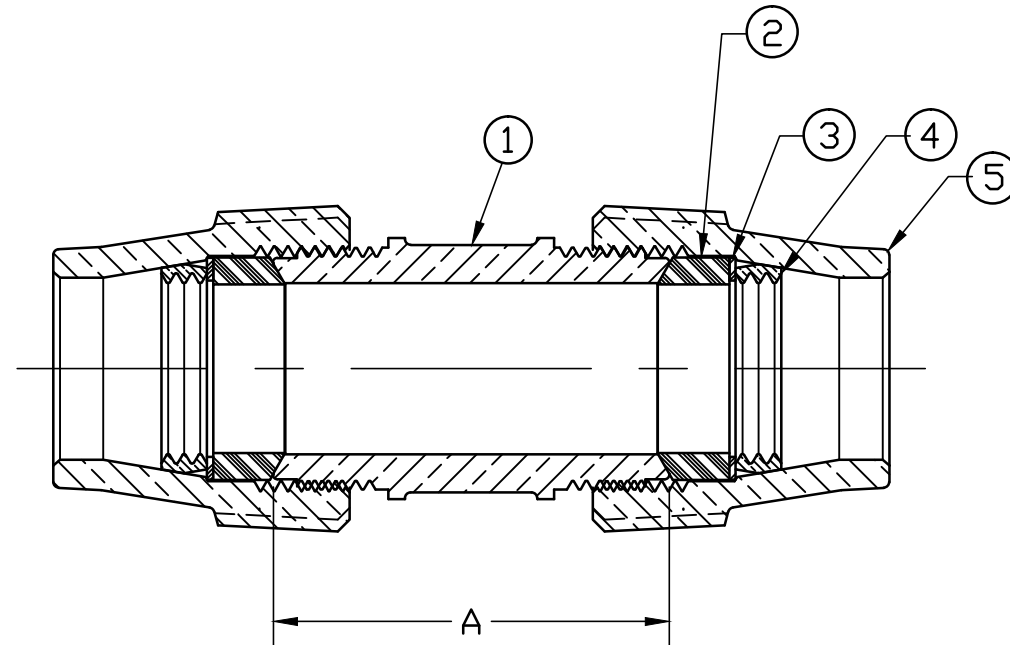
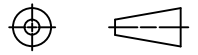

SIZE	A
3/4	2.062
1	2.406
1x3/4	1.835
1-1/2	3.312
1-1/2x1	2.840
2	3.375

FILEPATH: PRODD-ENG\MUELLER\ASYSUBMITTALS\G15403N

						DRFTR	RWB	6/19/13	Mueller Co.		UNLESS OTHERWISE NOTED SURFACE PREPARATION: BREAK CORNER(S) ----- .000 SURFACE FINISH -- XX RMS TOLERANCE(S): LINEAR ----- ± .000 ANGULAR ----- ± 0°00'		THIRD ANGLE PROJECTION  REF. No. SCALE NONE	
					CHKR									
					ENGR									
					MGR									
							BY	DATE	STK No:					
							MAT'L:		DESCR.		DWG NUMBER			
							STRAIGHT LLB SERVICE FITTING		G15403N					
							(MUELLER GRIP TYPE K)							
REV	ECR	DESCRIPTION	DATE	BY	CHKR	PER EST NO: DXXXX EST FIN WT = 0.0000 lbs								

TITLE TO AND OWNERSHIP OF THIS ENGINEERING DATA REMAINS IN Mueller Co. NO USE IS TO BE MADE OF THIS DATA EXCEPT AS SPECIFICALLY AUTHORIZED BY Mueller Co. ASSENT ON THE PART OF THE RECIPIENT TO THESE CONDITIONS IS PRESUMED

DWG NUMBER
G15403N
442-MRKTG