

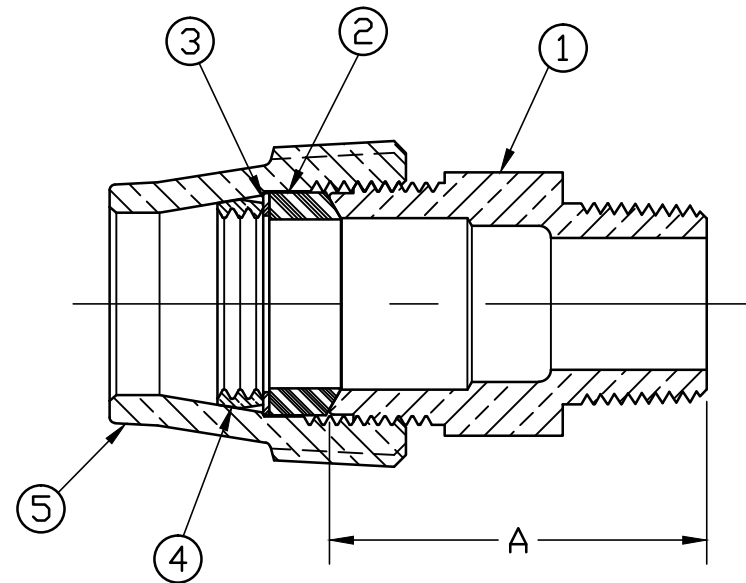

No.	DESCRIPTION	MATERIAL
1	SPUD	CAST LOW LEAD BRASS ALLOY
2	PJ GASKET	BUNA-N ASTM D2000
3	PJ WASHER	POLYPROPYLENE
4	COMPRESSION RING	BRASS ASTM B505 ALLOY C83600
5	COMPRESSION NUT	CAST BRASS ASTM B62 ALLOY C83600



SIZE	A
3/4	1.965
3/4x1	2.125
1	2.156
1x3/4	1.976
1-1/2	2.375
1-1/2x1	2.880
1-1/2x2	2.781
2	2.625
2x1-1/2	2.453

NOTE: ALL WETTED PARTS ARE LOW LEAD BRASS ALLOY

FILEPATH: PROD-ENG\MUELLER\ASTSUBMITTALS\G15428N

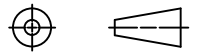
						DRFTR	RWB	6/19/13			THIRD ANGLE PROJECTION 	
						CHKR						
						ENGR						
						MGR						
									UNLESS OTHERWISE NOTED	REF. No.	SCALE	
									SURFACE PREPARATION:		NONE	
									BREAK CORNER(S) ----- .000			
									SURFACE FINISH -- 000 RMS			
									TOLERANCE(S):			
									LINEAR ----- ± .000			
									ANGULAR ----- ± 0°00'			
									STK No:			
									MAT'L:			
									DESCR.	STRAIGHT LLB SERVICE FITTING (CTS GRIP x MIP)		
											DWG NUMBER	
											G15428N	

TITLE TO AND OWNERSHIP OF THIS ENGINEERING DATA REMAINS IN Mueller Co. NO USE IS TO BE MADE OF THIS DATA EXCEPT AS SPECIFICALLY AUTHORIZED BY Mueller Co. ASSENT ON THE PART OF THE RECIPIENT TO THESE CONDITIONS IS PRESUMED

PER EST NO: DXXXX EST FIN WT = 0.0000 lbs

DWG NUMBER
G15428N
442-MRKTG