

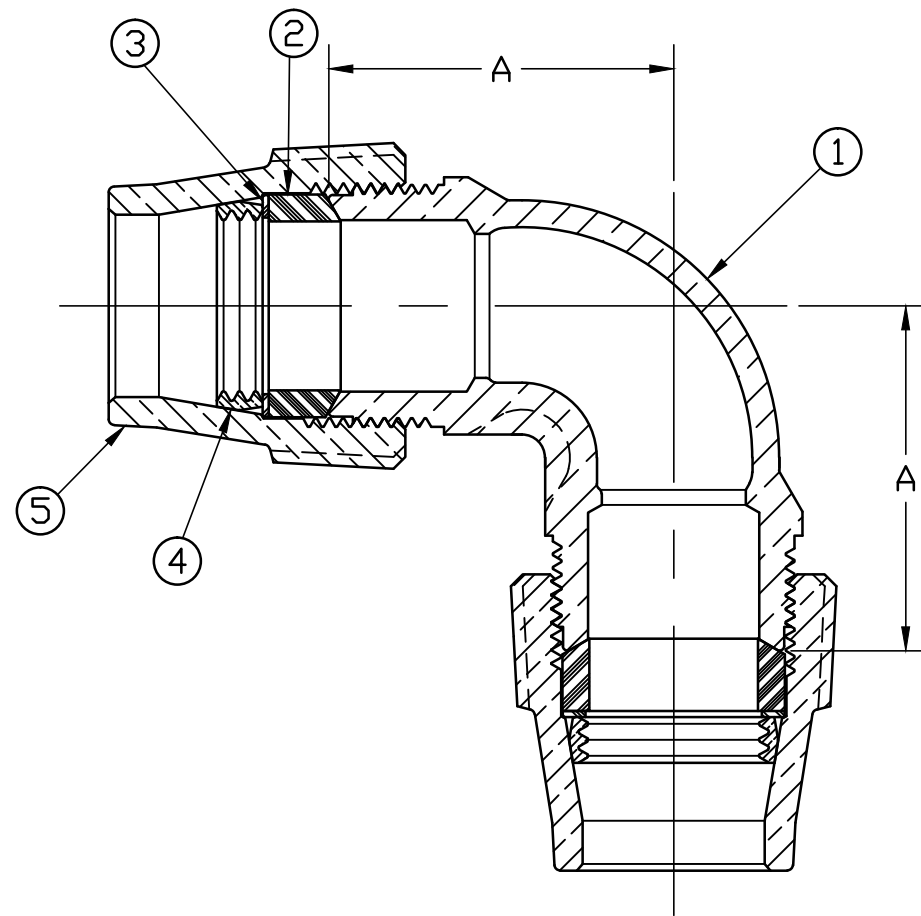

No.	DESCRIPTION	MATERIAL
1	SPUD	CAST LOW LEAD BRASS ALLOY
2	PJ GASKET	BUNA-N ASTM D2000
3	PJ WASHER	POLYPROPYLENE
4	COMPRESSION RING	BRASS ASTM B505 ALLOY C83600
5	COMPRESSION NUT	CAST BRASS ASTM B62 ALLOY C83600



SIZE	A
3/4	1.79
1	2.00
1x3/4	2.00
1-1/2	2.75
2	3.09

NOTE: ALL WETTED PARTS ARE LOW LEAD BRASS ALLOY

FILEPATH: PROD-ENG\MUELLER\ASYSUBMITTALS\G15526N

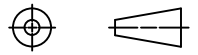
						DRFTR	RWB	4/23/14			THIRD ANGLE PROJECTION 			
						CHKR								
						ENGR								
						MGR								
											UNLESS OTHERWISE NOTED			
											SURFACE PREPARATION:			
											BREAK CORNER(S) ----- .000			
											SURFACE FINISH -- 000 RMS	REF. No.		
											TOLERANCE(S):	SCALE		
											LINEAR ----- ± .000	NONE		
											ANGULAR ----- ± 0°00'			
									STK No:					
									MAT'L:					
									DESCR.	1/4 BEND LLB SERVICE FITTING (CTS GRIP ENDS)		DWG NUMBER		
												G15526N		
									REV	ECR	DESCRIPTION	DATE	BY	CHKR
									PER EST NO: DXXXX EST FIN WT = 0.0000 lbs					

DWG NUMBER
G15526N
442-MRKTG

TITLE TO AND OWNERSHIP OF THIS ENGINEERING DATA REMAINS IN Mueller Co. NO USE IS TO BE MADE OF THIS DATA EXCEPT AS SPECIFICALLY AUTHORIZED BY Mueller Co. ASSENT ON THE PART OF THE RECIPIENT TO THESE CONDITIONS IS PRESUMED