

No.	DESCRIPTION	MATERIAL
1	RUBBER GASKET	NITRILE D2000
2	COUP. NUT	CAST BRASS ASTM B62 ALLOY C83600
3	TAILPIECE	CAST LOW LEAD BRASS ALLOY

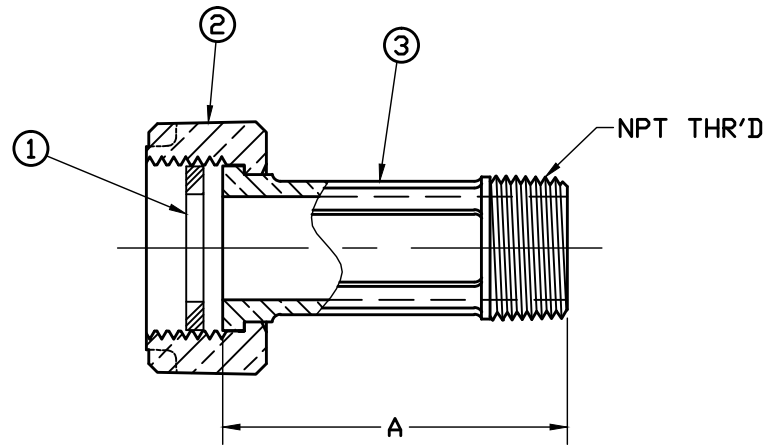

METER COUP. SIZE	A	NPT SIZE
5/8 x 3/4 x 3/4	2.500	3/4
1	2.625	1
1-1/4	2.641	1-1/4
1-1/2	2.844	1-1/2
2	3.031	2

NOTE: ALL WETTED PARTS ARE LOW LEAD BRASS ALLOY

FILEPATH: PRODD-ENG\MUELLER\ASYSUBMITTALS\H10891N

						DRFTR	RWB	2/17/10	Mueller Co.	UNLESS OTHERWISE NOTED SURFACE PREPARATION: BREAK CORNER(S) ---- .000 SURFACE FINISH -- XX RMS TOLERANCE(S): LINEAR ----- ± .000 ANGULAR ----- ± 0°00'	THIRD ANGLE PROJECTION
						CHKR					
						ENGR					
						MGR					
							BY	DATE	REF. No.	SCALE	
										NDNE	
							STK No.		DESCR. H-10891N STRIAIGHT METER COUPLING LOW LEAD BRASS (METER CPLG NUT x MIP)		PART NUMBER H10891N
							MAT'L				
REV	ECR	DESCRIPTION	DATE	BY	CHKR						

PART NUMBER
H10891N
442-MRKTG