

No.	DESCRIPTION	MATERIAL
1	TAILPIECE	CAST LOW LEAD BRASS ALLOY
2	COUP. NUT	CAST BRASS ASTM B62 ALLOY C83600
3	GASKET (*)	NITRILE ASTM D2000

* - NO GASKET PROVIDE WITH THE 1" SIZE

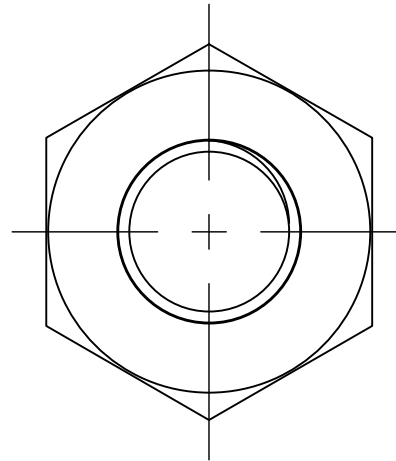
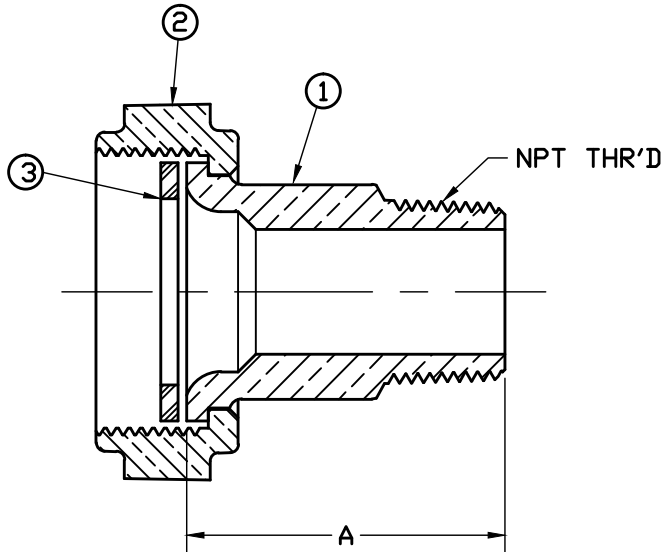

SIZE	A	NPT
5/8" x 3/4" x 3/4"	2.22	3/4"
5/8" x 3/4" x 1"	2.31	1"
1"	2.31	1"

NOTE: ALL WETTED PARTS ARE LOW LEAD BRASS ALLOY

FILEPATH: PROD-ENG\MUELLER\ASYSUBMITTALS\H14223N

				DRFTRJGarvin	2/3/11	Mueller Co.	
				CHKR			
				ENGR			
				MGR			
				BY	DATE	UNLESS OTHERWISE NOTED	THIRD ANGLE PROJECTION
				STK No:		SURFACE PREPARATION:	
				MAT'L:		BREAK CORNER(S) ---- .000	
				DESCR.		SURFACE FINISH -- XX RMS	REF. No.
				METER YOKE COUPLING		TOLERANCE(S):	SCALE
				LLB (MIP x MULTI THR'D)		LINEAR ----- ± .000	FULL
				PART NUMBER		ANGULAR ----- ± 0°00'	
REV	ECR	DESCRIPTION	DATE	BY	CHKR	PART NUMBER	
PER EST NO: DXXXX EST FIN WT = 0.00000 lbs						H14223N	

PART NUMBER
H14223N
442-MRKTG