

No.	DESCRIPTION	MATERIAL
1	SPUD	CAST LOW LEAD BRASS ALLOY
2	PLAIN GASKET	NEOPRENE ASTM D2000
3	RETAINER CUP	ASTM A245 STEEL
4	COUPLING NUT	CAST BRASS ASTM B62 ALLOY C83600
5	SET SCREW	STEEL

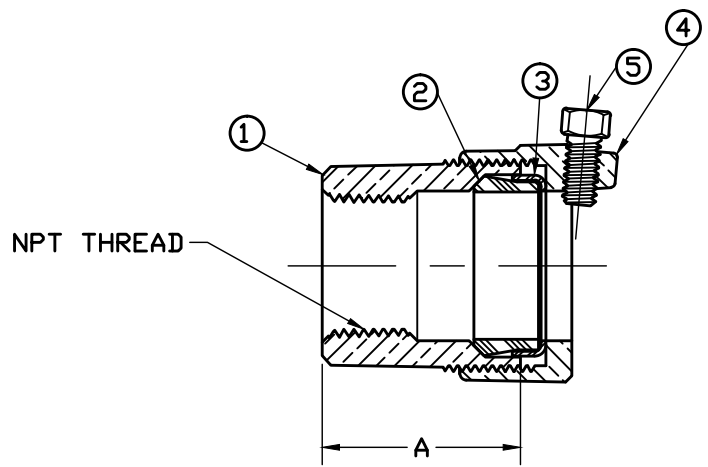

SIZE	A	NPT
5/8X3/4x3/4	1.438	3/4"
1	1.625	1"

PART NUMBER
H14233N
442-MRKTG

FILEPATH: PRODD-ENG\MUELLER\ASYSUBMITTALS\H14233N

						DRFTR JGarvin 7/19/10	Mueller Co.	UNLESS OTHERWISE NOTED SURFACE PREPARATION: BREAK CORNER(S) ---- .000 SURFACE FINISH -- XX RMS TOLERANCE(S): LINEAR ----- ± .000 ANGULAR ----- ± 0°00'	THIRD ANGLE PROJECTION		
									REF. No.	SCALE	
						BY			DATE		
						STK No:					
						MAT'L:					
REV	ECR	DESCRIPTION	DATE	BY	CHKR	DESCR: METER YOKE COUPLING LOW LEAD BRASS (FIP x COMPRESSION CONNECTION STEEL PIPE)			PART NUMBER H14233N		
PER EST NO: DXXXX EST FIN WT = 0.0000 lbs											