

NO.	DESCRIPTION	MATERIAL
1	1st POPPER FACING	RUBBER ASTM D2000 NATURAL RUBBER
2	1st POPPET	CELCON GRADE M90-04 NATURAL COLOR
3	1st POPPET SPRING	STAINLESS STEEL ASTM A313 TYPE 302
4	2nd POPPER FACING	RUBBER ASTM D2000 NATURAL RUBBER
5	2nd POPPET	CELCON GRADE M90-04 NATURAL COLOR
6	2nd POPPET SPRING	STAINLESS STEEL ASTM A313 TYPE 302
7	ORING	RUBBER ASTM D2000 EPDM
8	CAP	CAST LOW LEAD BRASS ALLOY
9	BODY	CAST LOW LEAD BRASS ALLOY
10	SNAP RING	BRASS BAR ASTM B134 CDA 521
11	RUBBER GASKET	RUBBER ASTM D2000 NITRILE
12	SADDLE NUT	CAST BRASS ASTM B62 ALLOY C83600

SIZE	A
5/8"x3/4"x3/4"	4.03
5/8"x3/4"x1"	4.47
1"	4.67
1 1/2"	5.19
2"	5.19

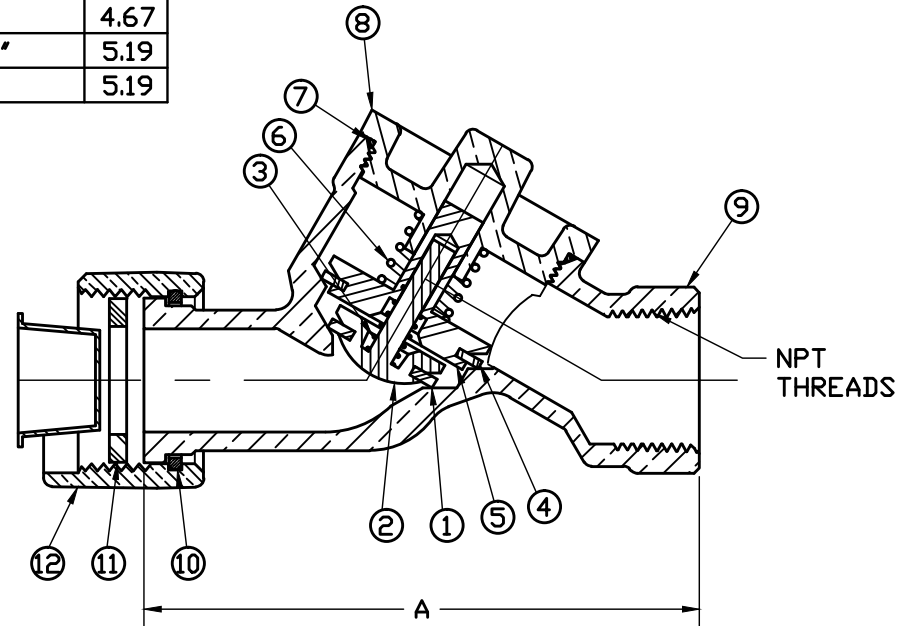

NOTE: ALL WETTED PARTS ARE LOW LEAD BRASS ALLOY

FILEPATH: PROD-ENG\MUELLER\ASYSUBMITTALS\H14242N

DRFTR	RWB	12/21/09	Mueller Co.	UNLESS OTHERWISE NOTED THIRD ANGLE PROJECTION SURFACE PREPARATION: BREAK CORNER(S) ---- .000 SURFACE FINISH -- XX RMS TOLERANCE(S): LINEAR ----- ± .000 ANGULAR ----- ± 0°00'			
CHKR							
ENGR							
MGR							
BY	DATE		REF. No.	SCALE			
STK No.				NONE			
MAT'L:							
DESCR.	INLINE DUAL CHECK VALVE LOW LEAD BRASS (MTR x FIP)			PART NUMBER			
REV	ECR	DESCRIPTION	DATE	BY	CHKR		H14242N
PER EST NO: DXXXX EST FIN WT = 0.0000 lbs							

PART NUMBER
H14242N
442-MRKTNG