

NO.	DESCRIPTION	MATERIAL
1	1st POPPER FACING	RUBBER ASTM D2000 NATURAL RUBBER
2	1st POPPET	CELCON GRADE M90-04 NATURAL COLOR
3	1st POPPET SPRING	STAINLESS STEEL ASTM A313 TYPE 302
4	2nd POPPER FACING	RUBBER ASTM D2000 NATURAL RUBBER
5	2nd POPPET	CELCON GRADE M90-04 NATURAL COLOR
6	2nd POPPET SPRING	STAINLESS STEEL ASTM A313 TYPE 302
7	ORING	RUBBER ASTM D2000 EPDM
8	CAP	CAST LOW LEAD BRASS ALLOY
9	BODY	CAST LOW LEAD BRASS ALLOY
10	LOCKNUT	CAST BRASS ASTM B62 ALLOY C83600
11	RUBBER GASKET	RUBBER ASTM D2000 NITRILE

SIZE	A
5/8"x3/4"	3.91
5/8"x3/4"x3/4"	3.91

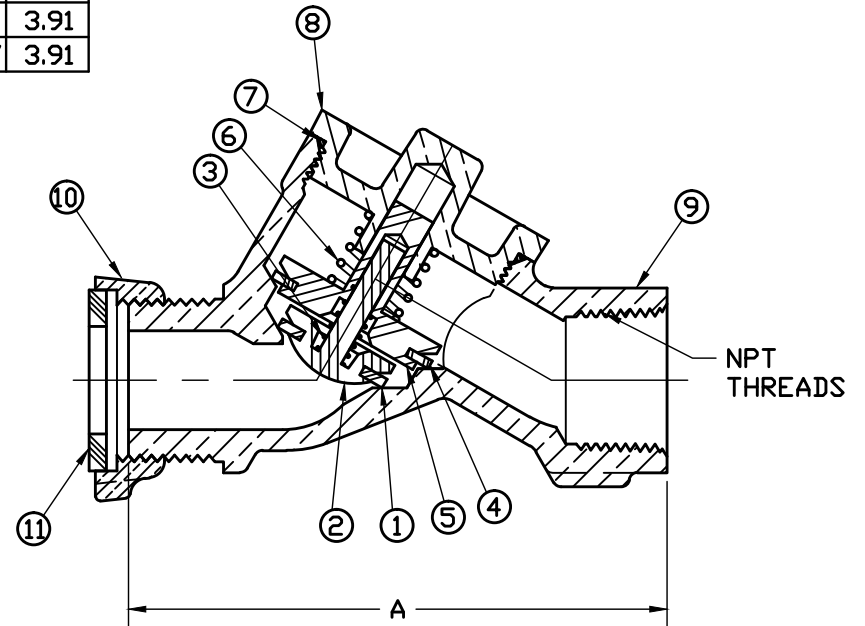

**NOTE:** ALL WETTED PARTS ARE LOW LEAD BRASS ALLOY

FILEPATH: PROD-ENG\MUELLER\ASYSUBMITTALS\H14247N

						DRFTR   jGarvin   10/26/10	<b>Mueller Co.</b>		UNLESS OTHERWISE NOTED SURFACE PREPARATION: BREAK CORNER(S) ---- .000 SURFACE FINISH -- XX RMS TOLERANCE(S): LINEAR ----- ± .000 ANGULAR ----- ± 0°00'		THIRD ANGLE PROJECTION 			
						CHKR							REF. No.	SCALE
						ENGR								
						MGR								NONE
						BY	DATE							
						STK No:								
						MAT'L:								
REV	ECR	DESCRIPTION	DATE	BY	CHKR	DESCR. INLINE DUAL CHECK VALVE - LL BRASS (5000 SERIES MTR BAR x FIP)			PART NUMBER H14247N					
PER EST NO: DXXXX EST FIN WT = 0.0000 lbs														

PART NUMBER  
 H14247N  
 442-MRKTNG