

No.	DESCRIPTION	MATERIAL
1	KEY CAP	CAST BRASS ASTM B62 ALLOY C83600
2	PIN	BRASS ASTM B16 ALLOY C36000
3	SPRING WASHER	PHOS BRONZE
4	O-RING	EPDM ASTM D2000
5	KEY	CAST LOW LEAD BRASS ALLOY
6	BODY	CAST LOW LEAD BRASS ALLOY
7	LOCK NUT	CAST BRASS ASTM B62 ALLOY C83600
8	RUBBER GASKET	NITRILE ASTM D2000
9	SWIVEL BUSHING	CAST LOW LEAD BRASS ALLOY
10	O-RING	EPDM ASTM D2000
11	TUBE NUT	CAST BRASS ASTM B62 ALLOY C83600

METER CONNX SIZE	A	B
5/8 x 3/4	1.69	2.01
5/8 x 3/4 x 3/4	1.69	2.01

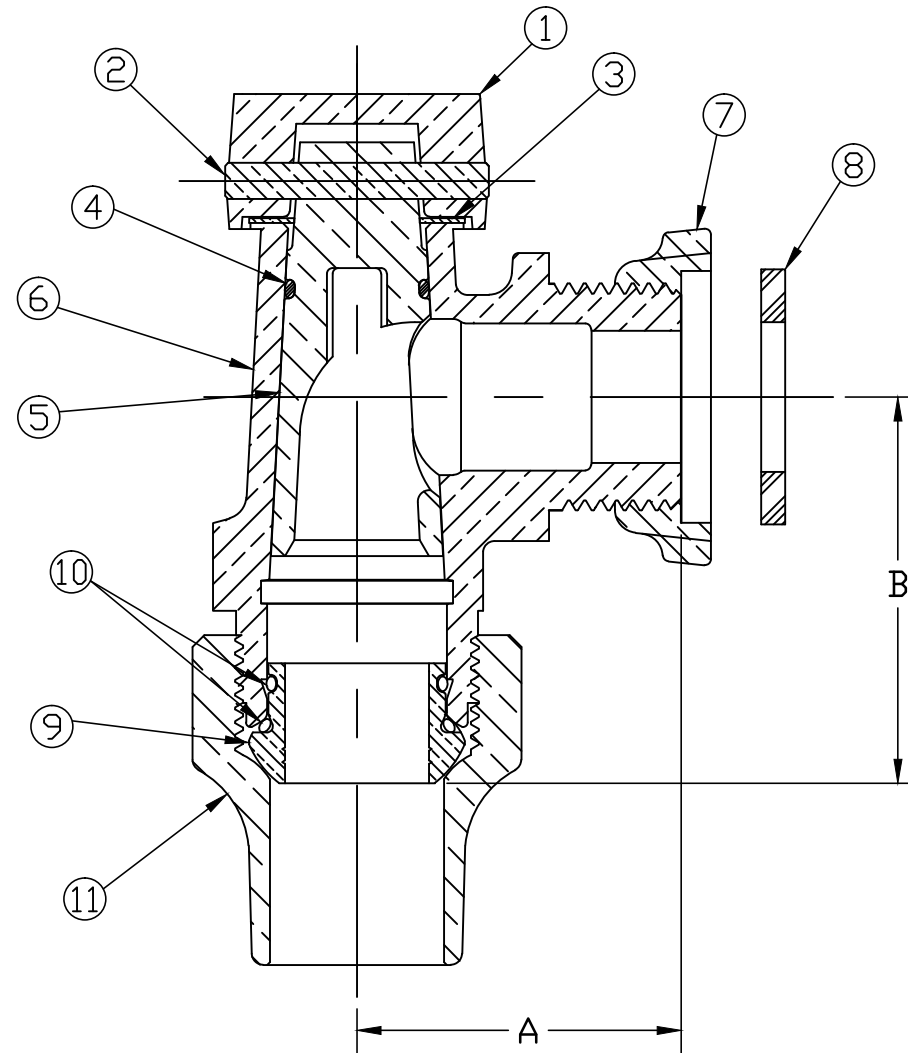

NOTE: ALL WETTED PARTS ARE LOW LEAD BRASS ALLOY

FILEPATH: PROD-ENG\MUELLER\ASYSUBMITTALS\H14264N

REV	ECR	DESCRIPTION	DATE	BY	CHKR	DRFTR	RWB	1/11/13	Mueller Co.	
									UNLESS OTHERWISE NOTED	
									THIRD ANGLE PROJECTION	
									SURFACE PREPARATION:	
									BREAK CORNER(S) ----- .000	
									SURFACE FINISH -- XX RMS	
									TOLERANCE(S):	
									LINEAR ----- ± .000	
									ANGULAR ----- ± 0°00'	
									REF. No.	SCALE
										FULL
									STK No:	
									MAT'L:	
									DESCR.	
									ANGLE METER STOP - LLB	
									CS x IRON BAR	
									DWG NUMBER	
									H14264N	
									PER EST NO: DXXXX EST FIN WT = 0.0000 lbs	

DWG NUMBER
H14264N
442-MRKTG

TITLE TO AND OWNERSHIP OF THIS ENGINEERING DATA REMAINS IN Mueller Co. NO USE IS TO BE MADE OF THIS DATA EXCEPT AS SPECIFICALLY AUTHORIZED BY Mueller Co. ASSENT ON THE PART OF THE RECIPIENT TO THESE CONDITIONS IS PRESUMED