

ITEM	DESCRIPTION	MATERIAL DESCRIPTION
1	BRANCH	CAST LOW LEAD BRASS ALLOY
2	CONNX NUT	CAST BRASS ASTM B62 ALLOY C83600
3	GASKET	ASTM D2000 (SBR)

SIZE	A	B	C
3/4" x 3/4" x 7-1/2"	7.50	1.61	3.65
1" x 3/4" x 6-1/2"	6.50	1.56	3.49
1" x 3/4" x 7-1/2"	7.50	1.56	3.49
1" x 3/4" x 13-1/2"	13.50	1.61	3.57
1-1/2" x 3/4" x 7-1/2"	7.50	1.49	3.38
1" x 1" x 7-1/2"	7.50	1.59	3.52
1-1/2" x 1" x 7-1/2"	7.50	1.61	3.50

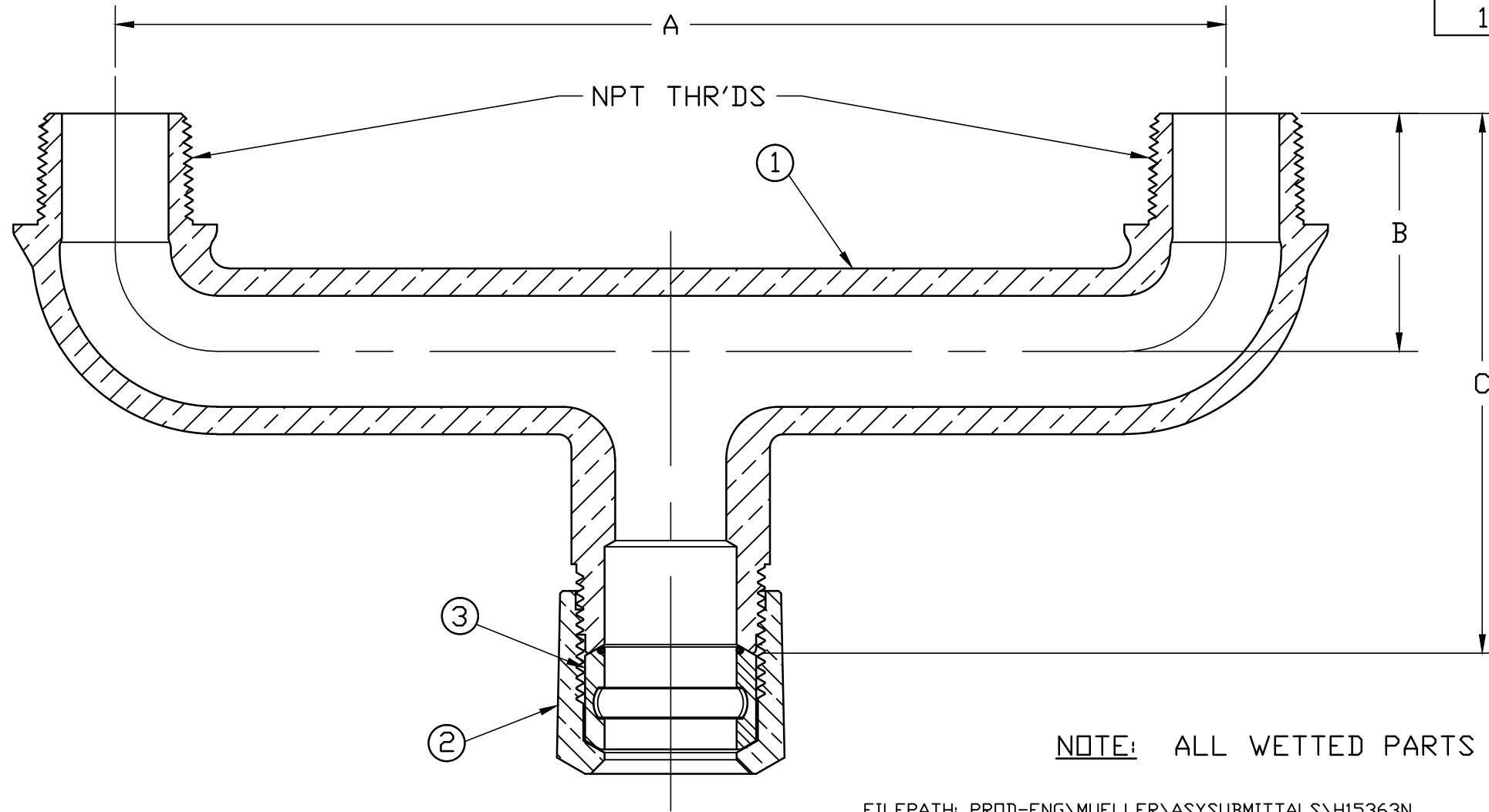

NOTE: ALL WETTED PARTS ARE LOW LEAD BRASS ALLOY

FILEPATH: PROD-ENG\MUELLER\ASYSUBMITTALS\H15363N

DRFTR	RWB	1/7/11	<b>Mueller Co.</b>	
CHKR				
ENGR				
MGR				
			UNLESS OTHERWISE NOTED	THIRD ANGLE PROJECTION
			SURFACE PREPARATION:	
			BREAK CORNER(S) ---- .000	REF. No.
			SURFACE FINISH -- XX RMS	SCALE
			TOLERANCE(S):	NONE
			LINEAR ----- ± .000	
			ANGULAR ----- ± 0°00'	
			BY	DATE
			STK No:	
			MAT'L:	
			DESCR.	
			U-BRANCH CONNECTION	DWG NUMBER
			LOW LEAD BRASS (110 CTS x MIP)	H15363N
A	3917	REM'D 1x1x13.5	12/7/12	RWB
REV	ECR	DESCRIPTION	DATE	BY
				CHKR
PER EST NO: DXXXX EST FIN WT = 0.0000 lbs				

DWG NUMBER  
H15363N  
442-MRKTNG

TITLE TO AND OWNERSHIP OF THIS ENGINEERING DATA REMAINS IN Mueller Co. NO USE IS TO BE MADE OF THIS DATA EXCEPT AS SPECIFICALLY AUTHORIZED BY Mueller Co. ASSENT ON THE PART OF THE RECIPIENT TO THESE CONDITIONS IS PRESUMED