

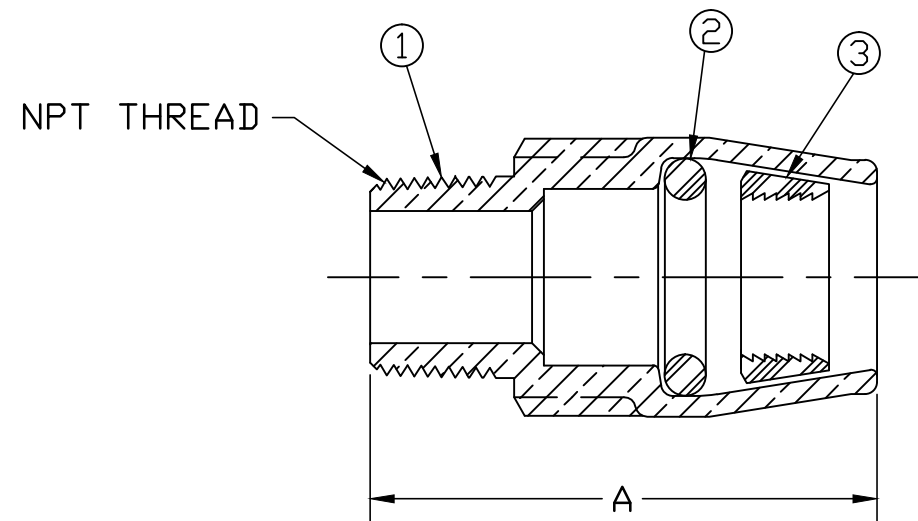

No.	DESCRIPTION	MATERIAL
1	SPUD	CAST LOW LEAD BRASS ALLOY
2	O-RING	EP ASTM D2000 RUBBER
3	GRIP RING	CELCON M90 RED CF2001



SIZE	A	NPT
3/4	2.64	3/4"
1	2.92	1"

ALL WETTED PARTS ARE LOW LEAD BRASS ALLOY

FILEPATH: PROD-ENG\MUELLER\ASYSUBMITTALS\H15424N

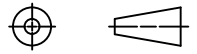
						DRFTR	RWB	5/29/13			
						CHKR					
						ENGR					
						MGR					
									UNLESS OTHERWISE NOTED	THIRD ANGLE PROJECTION	
									SURFACE PREPARATION:		
									BREAK CORNER(S) ---- .000		
									SURFACE FINISH -- XX RMS	REF. No.	SCALE
									TOLERANCE(S):		FULL
									LINEAR ----- ± .000		
									ANGULAR ----- ± 0°00'		
									STK No:		
									MAT'L:		
									DESCR.	LLB SERVICE FITTING (MIP x INSTA-TITE)	DWG NUMBER H15424N
REV	ECR	DESCRIPTION	DATE	BY	CHKR	PER EST NO: DXXXX EST FIN WT = 0.0000 lbs					

DWG NUMBER
H15424N
442-MRKTG

TITLE TO AND OWNERSHIP OF THIS ENGINEERING DATA REMAINS IN Mueller Co. NO USE IS TO BE MADE OF THIS DATA EXCEPT AS SPECIFICALLY AUTHORIZED BY Mueller Co. ASSENT ON THE PART OF THE RECIPIENT TO THESE CONDITIONS IS PRESUMED