

No.	DESCRIPTION	MATERIAL
1	SPUD	CAST LOW LEAD BRASS ALLOY
2	IPS PE GSKT	ASTM D2000(SBR)&410 STAINLESS STEEL
3	CONN NUT	CAST BRASS ASTM B62 ALLOY C83600

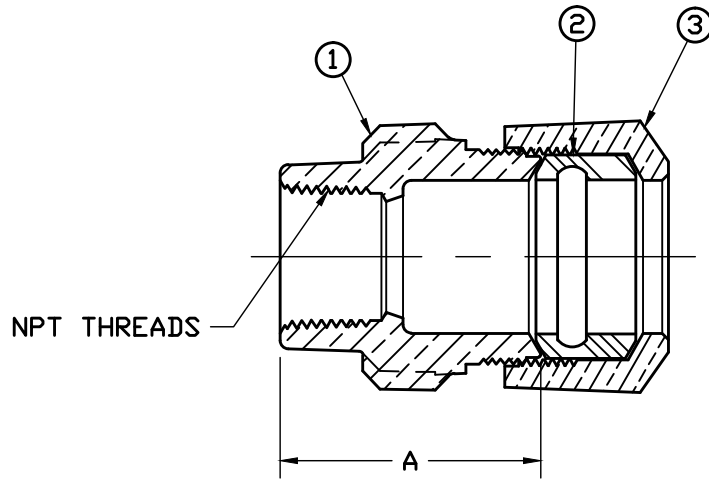

SIZE	A
3/4	1.89
1	2.19
1 x 3/4	2.14

**NOTE:** ALL WETTED PARTS ARE LOW LEAD BRASS ALLOY

FILEPATH: PROD-ENG\MUELLER\ASYSUBMITTALS\H15454N

						DRFTR	RWB	12/21/09	<b>Mueller Co.</b>	
						CHKR				
						ENGR				
						MGR				
							BY	DATE	UNLESS OTHERWISE NOTED	
									THIRD ANGLE PROJECTION	
									SURFACE PREPARATION:	
									BREAK CORNER(S) ---- .000	
									SURFACE FINISH -- XX RMS	
									TOLERANCE(S):	
									LINEAR ----- ± .000	
									ANGULAR ----- ± 0°00'	
									REF. No.	SCALE
										NONE
									PART NUMBER	
									H15454N	
									DESCR.	
									STRAIGHT SERVICE FITTING	
									LOW LEAD BRASS (FIP x 110 IPS)	
									PER EST NO: DXXXX EST FIN WT = 0.0000 lbs	

PART NUMBER  
H15454N  
442-MRKTNG