

No.	DESCRIPTION	MATERIAL
1	GASKET	FIBER ASTM D710
2	TUBE NUT	CAST BRASS ASTM B62 ALLOY C83600
3	SPUD	CAST LOW LEAD BRASS ALLOY

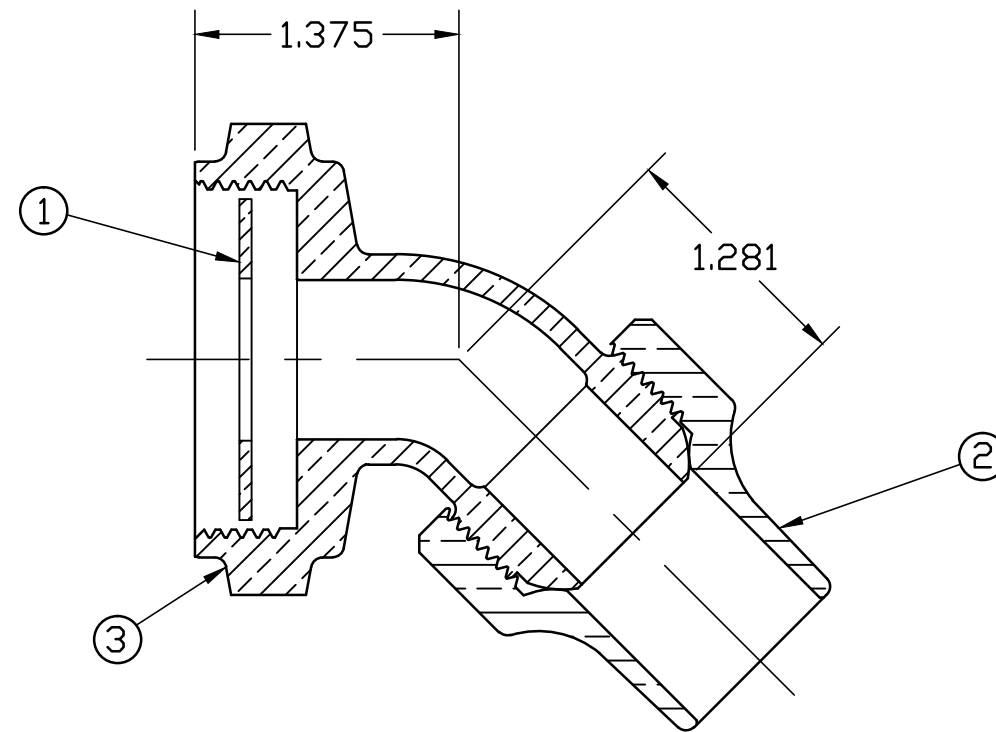

SIZE	A	B
5/8" x 3/4"	1.38	1.28
3/4"	1.38	1.28
1"	1.50	1.44

ALL WETTED PARTS ARE LOW LEAD BRASS ALLOY

FILEPATH: PROD-ENG\MUELLER\APPROVED\H15515N

						DRFTR	RWB	8/25/15	Mueller Co.	THIRD ANGLE PROJECTION
						CHKR				
						ENGR				
						MGR				
									UNLESS OTHERWISE NOTED	
									SURFACE PREPARATION:	
									BREAK CORNER(S) ---- .000	REF. No.
									SURFACE FINISH -- 000 RMS	SCALE
									TOLERANCE(S):	NONE
									LINEAR ----- ± .000	
									ANGULAR ----- ± 0°00'	
								STK No:		
								MAT'L:		
								DESCR.	1/8 BEND LLB CORP. STOP COUPLING (INSIDE XS LEAD x CS OUTLET)	DWG NUMBER H15515
REV	ECR	DESCRIPTION	DATE	BY	CHKR	PER EST NO: DXXXX EST FIN WT = 0.0000 lbs				

TITLE TO AND OWNERSHIP OF THIS ENGINEERING DATA REMAINS IN Mueller Co. NO USE IS TO BE MADE OF THIS DATA EXCEPT AS SPECIFICALLY AUTHORIZED BY Mueller Co. ASSENT ON THE PART OF THE RECIPIENT TO THESE CONDITIONS IS PRESUMED

DWG NUMBER
H15515N
442-MRKTG