

No.	DESCRIPTION	MATERIAL DESCRIPTION
1	SPUD	CAST LOW LEAD BRASS ALLOY
2	CTS GASKET SUB	ASTM D2000(SBR)&410 STAINLESS STEEL
3	CONN NUT	CAST BRASS ASTM B62 ALLOY C83600

SIZE	A	B
3/4"	1.33	1.25
1"	1.43	1.43

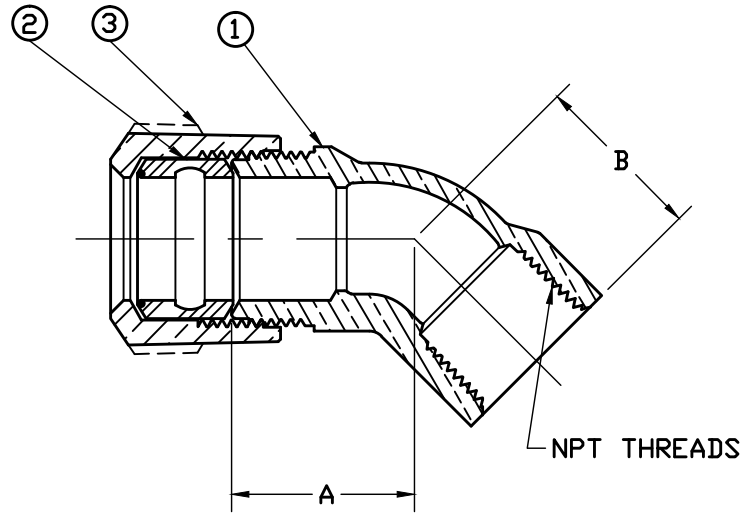

NOTE: ALL WETTED PARTS ARE LOW LEAD BRASS ALLOY

FILEPATH: PROD-ENG\MUELLER\ASYSUBMITTALS\H15534N

						DRF TR J Garvin	12/21/09	Mueller Co.	
						CHKR			
						ENGR			
						MGR			
						BY	DATE	UNLESS OTHERWISE NOTED	THIRD ANGLE PROJECTION
								SURFACE PREPARATION:	
								BREAK CORNER(S) ---- .000	REF. No.
								SURFACE FINISH --XX RMS	SCALE
								TOLERANCE(S):	FULL
								LINEAR ----- ± .000	
								ANGULAR ----- ± 0°00'	
						STK No:		DESCR. EIGHTH BEND SERVICE FITTING	
						MAT'L:		LOW LEAD BRASS (110CTS x FIP)	
REV	ECR	DESCRIPTION	DATE	BY	CHKR	PART NUMBER H15534N			
PER EST NO: DXXXX EST FIN WT = 0.0000 lbs									

PART NUMBER
H15534N
442-MRKTG