

No.	DESCRIPTION	MATERIAL
1	SPUD	CAST LOW LEAD BRASS ALLOY
2	TAILPIECE SUB	CAST LOW LEAD BRASS ALLOY W/ ZYTEL NYLON
3	O-RING	RUBBER ASTM D2000
4	COUPLING NUT	CAST BRASS ASTM B62 ALLOY C83600

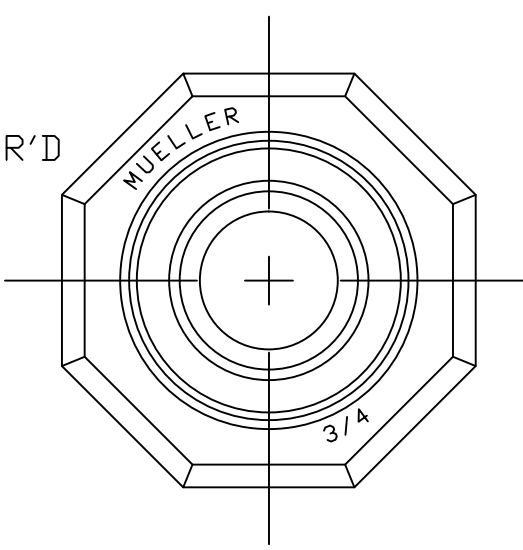
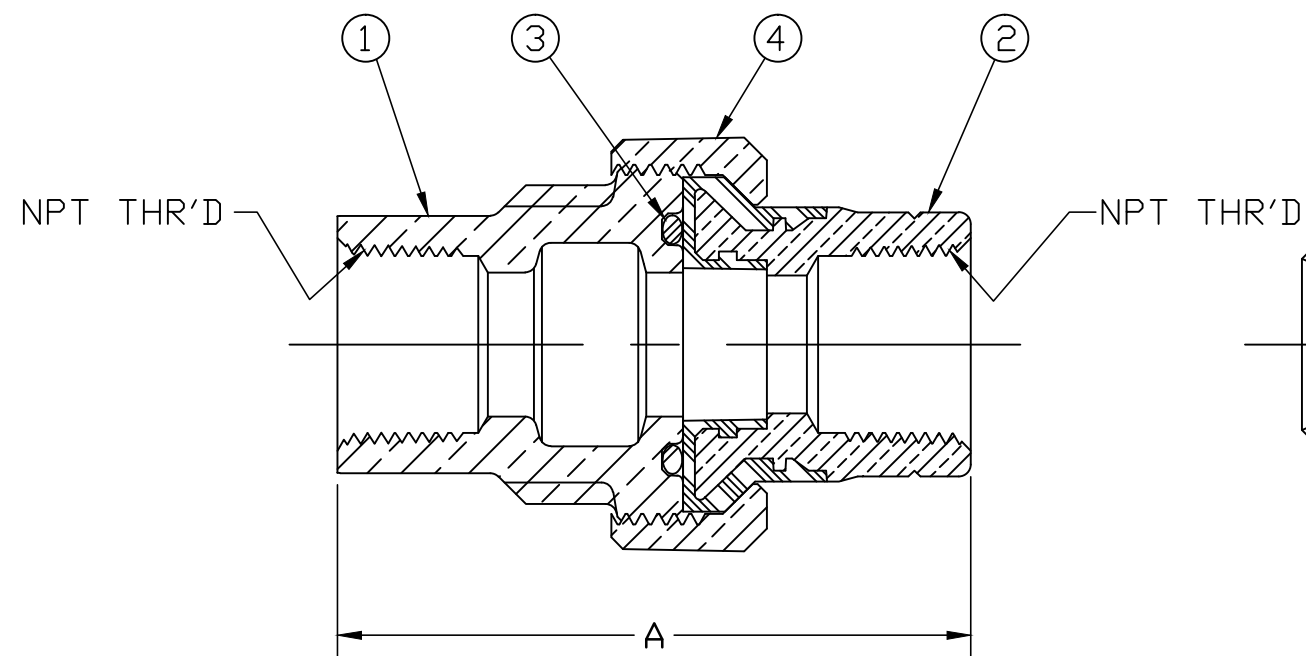

SIZE	A	NPT
3/4	3.30	3/4"
1	3.39	1"

**NOTE:** ALL WETTED PARTS ARE LOW LEAD BRASS ALLOY

FILEPATH: PROD-ENG\MUELLER\ASYSUBMITTALS\N30077N

DRFTR	RWB	3/18/13	<b>Mueller Co.</b>	THIRD ANGLE PROJECTION 					
CHKR									
ENGR									
MGR									
	BY	DATE	UNLESS OTHERWISE NOTED	REF. No.					
			SURFACE PREPARATION:	SCALE					
			BREAK CORNER(S) ---- .000	FULL					
			SURFACE FINISH -- XX RMS						
			TOLERANCE(S):						
			LINEAR ----- ± .000						
			ANGULAR ----- ± 0°00'						
REV	ECR	DESCRIPTION	DATE	BY	CHKR	STK No:	MAT'L:	DESCR.	DWG NUMBER
								INSULATED LLB SERVICE FITTING (FIP x FIP)	N30077N
PER EST NO: DXXXX EST FIN WT = 0.0000 lbs									

DWG NUMBER  
N30077N  
442-MRKTG

TITLE TO AND OWNERSHIP OF THIS ENGINEERING DATA REMAINS IN Mueller Co. NO USE IS TO BE MADE OF THIS DATA EXCEPT AS SPECIFICALLY AUTHORIZED BY Mueller Co. ASSENT ON THE PART OF THE RECIPIENT TO THESE CONDITIONS IS PRESUMED