

No.	DESCRIPTION	MATERIAL
1	SPUD	CAST LOW LEAD BRASS ALLOY
2	PJ GASKET	ASTM D2000 (BUNA N)
3	PJ WASHER	POLYPROPYLENE
4	PJ CPLG NUT	CAST BRASS ASTM B62 ALLOY C83600

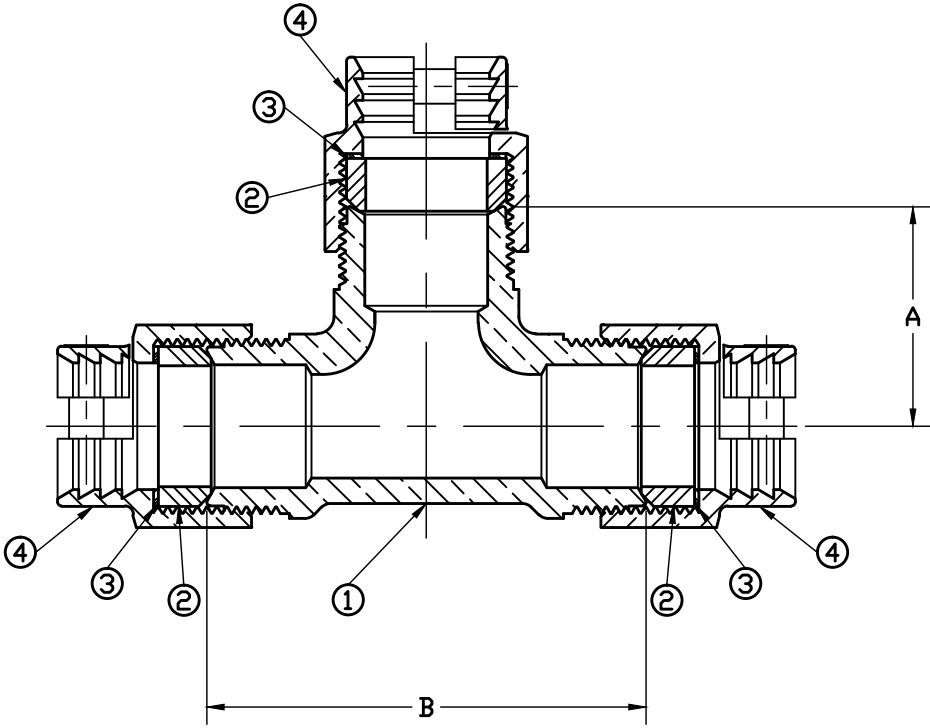

SIZE	A	B
3/4	1.59	3.19
3/4x3/4x1	2.00	3.70
1	2.06	4.12
1x1x3/4	1.54	3.41
1-1/2	2.12	4.25
2	2.50	5.00
2x2x3/4	2.33	4.12

NOTE: ALL WETTED PARTS ARE LOW LEAD BRASS ALLOY

FILEPATH: PRODD-ENG\MUELLER\ASYSUBMITTALS\P15381N

						DRFTR JGarvin 7/19/10	Mueller Co.		UNLESS OTHERWISE NOTED SURFACE PREPARATION: BREAK CORNER(S) ---- .000 SURFACE FINISH -- XX RMS TOLERANCE(S): LINEAR ----- ± .000 ANGULAR ----- ± 0°00'		THIRD ANGLE PROJECTION 			
						CHKR							REF. No.	SCALE
						ENGR								FULL
						MGR								
						BY	DATE							
						STK No:								
						MAT'L:								
REV	ECR	DESCRIPTION	DATE	BY	CHKR	DESCR. "TEE" (PJ CTS)-LOW LEAD BRASS						PART NUMBER		
PER EST NO: DXXXX EST FIN WT = 0.0000 lbs												P15381N		

PART NUMBER
P15381N
442-MRKTG