

No.	DESCRIPTION	MATERIAL
1	SPUD	CAST LOW LEAD BRASS ALLOY
2	CLPG NUT SUB	CAST BRASS ASTM B62 ALLOY C83600
3	PJ CTS GSKT	BUNA N ASTM D2000
4	PJ WASHER	POLYPROPYLENE

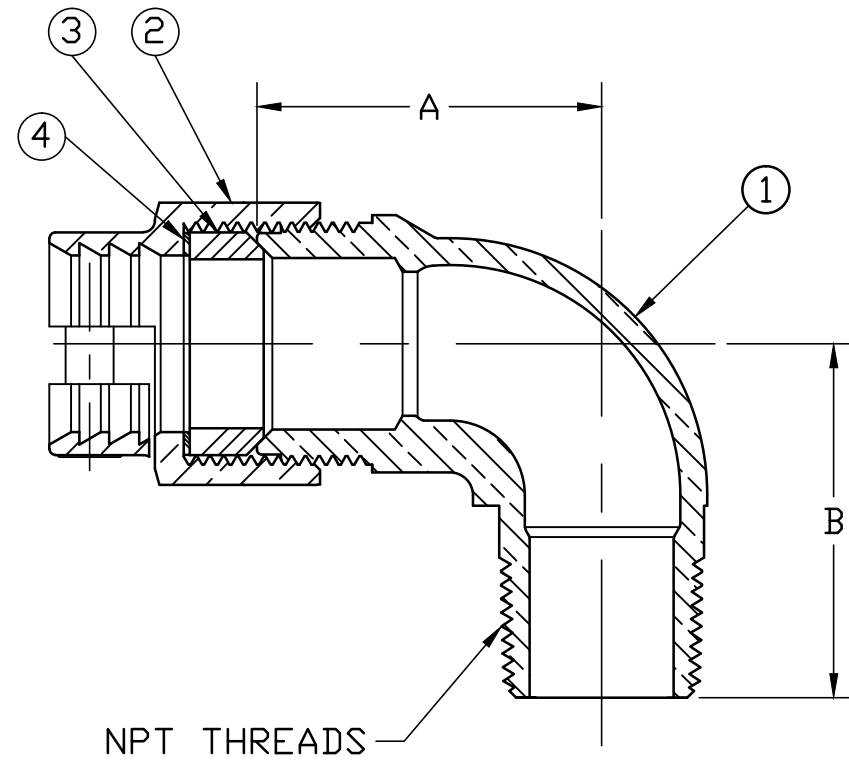

SIZE	A	B
3/4	1.796	1.844
3/4x1	2.000	2.000
1	2.000	2.000
1x3/4	2.000	2.000
1-1/2	2.750	2.625
2	3.094	2.969

ALL WETTED PARTS ARE LOW LEAD BRASS ALLOY

FILEPATH: PROD-ENG\MUELLER\ASYSUBMITTALS\P15531N

						DRFTR	RWB	9/16/15	Mueller Co.	UNLESS OTHERWISE NOTED THIRD ANGLE PROJECTION SURFACE PREPARATION: BREAK CORNER(S) ---- .000 SURFACE FINISH -- XX RMS TOLERANCE(S): LINEAR ----- ± .000 ANGULAR ----- ± 0°00'	REF. No.	SCALE NONE
						CHKR						
						ENGR						
						MGR						
								BY	DATE			
								STK No:				
								MAT'L:				
								DESCR.	LLB 1/4 BEND SERVICE FITTING (PJ CTS x MIP)			
											DWG NUMBER P15531N	

TITLE TO AND OWNERSHIP OF THIS ENGINEERING DATA REMAINS IN Mueller Co. NO USE IS TO BE MADE OF THIS DATA EXCEPT AS SPECIFICALLY AUTHORIZED BY Mueller Co. ASSENT ON THE PART OF THE RECIPIENT TO THESE CONDITIONS IS PRESUMED.

REV ECR DESCRIPTION DATE BY CHKR
PER EST NO: DXXXX EST FIN WT = 0.0000 lbs

DWG NUMBER
P15531N
442-MRKTG