

SECTION A-A

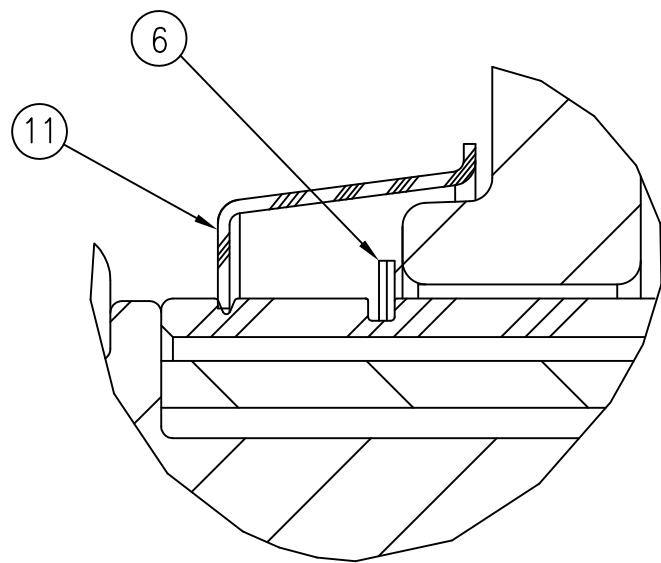

DETAIL A
SCALE 4.000

UL 789 LISTED. ASSEMBLED IN THE UNITED STATES

POST INDICATOR PAINT SPEC:

WRENCH: One coat of black primer .5-1.5 mils from the HMC Dip Line and one coat of Polane SP (Mueller Red) 2-3 mils.

CENTER BARREL/UPPER BARREL: One coat of neutral orange primer 2-3 mils and one coat of Polane SP (Mueller Red) 2-3 mils.

BELL: One coat of black primer .5-1.5 mils from HMC Dip Line.

POST HEAD & COVER: One coat of black primer .5-1.5 mils from the HMC Dip Line all surfaces inside and out and one coat of Polane SP (Mueller Red) 2-3 mils on exterior.

(K) (G) (F)

(L)

(A)

(A)

ITEM No.	PART NO.	CAT. PART NO.	DESCRIPTION	MATERIAL	MATERIAL STANDARD
1	290553	P206	SHUT TARGET	PLASTIC	ZYTEL
2	290552	P209	OPEN TARGET	PLASTIC	ZYTEL
3	290154	P217	COTTER PIN (SHORT)	BRASS	ASTM B21
4	290155	P218	COUPLING	STEEL	ASTM A500 GR.B
5	290154	P219	COTTER PIN (LONG)	BRASS	ASTM B21
6	290157	P242	RETAINING RING	STAINLESS STEEL	AISI 302
7	290631	P244	HEX BOLT	STEEL/ZINC PLATED	ASTM A307/SAE J429
8	148689	P273	BELL	CAST IRON	ASTM A126 CL.B
9	190939	P303	HEX NUT	STEEL/ZINC PLATED	ASTM A563 GR.A
10	148691-1	P304	OPERATING NUT	DUCTILE IRON	ASTM A536 GR.65-45-12
11	290143	P305	CAP	POLYPROPYLENE	
12	190330	P307	SPRING PIN	STAINLESS STEEL	AISI 420
13	241011	P308	THREADED SLEEVE	PLASTIC	ZYTEL
14	148633	P309	UPPER STEM	STEEL	ASTM A513
15	198582	P315	PIPE PLUG - HEX SOCKET	STEEL	
16	148692	P248	POST HEAD	CAST IRON	ASTM A126 CLASS B
17	148790	P317	WINDOW	MOLDED PLASTIC	
18	190560	P322	HEX HEAD SCREW	STEEL/ZINC PLATED	ASTM A307 GR.A
19	148760	P323	LOWER BARREL	PVC	DR14 UL LISTED
20	147307	P324	UPPER BARREL	STEEL	ASTM A53 GR.B
21	241013	P325	WRENCH	STEEL	ASTM A36 H.R.S.
22	290137	P326	LOWER STEM	STEEL	ASTM A500 GR.B
23	198428	P329	SOCKET HEAD SET SCREW	STEEL	ANSI B18.3
24	290156	P350	COUPLING INSERT	STEEL	ASTM A500 GR.B
25	290164	P352	SHIPPING DISC *	PRESS BOARD	

* ITEMS NOT SHOWN

DWG. No. A20807

REV.	DESCRIPTION	REF.	DRFT'R	CHK'R	APP	DATE
L	REVISE MATERIAL ON ITEM#13	E04027	ANC	CJD	CJD	12-14-16
K	REVISE MATERIAL STANDARD ON ITEM#7		ANC			9-7-16
J	REMOVE "CENTER BARREL" & "COVER" FROM PAINT SPEC		ANC			7-19-16
H	REVISED PAINT SPEC TO ERS-0075		ANC		CJD	6-24-14
G	REVISED ITEM #7 PART NUMBER FROM 190980 TO 290631		ANC			1-27-14
F	REVISED ITEM #7 PART NUMBER		ANC			8-27-13
E	REVISED ITEM #16 MATERIAL	E03347	JBC	JMG	CJD	3-9-12
D	REVISED ITEM #16 PART # AND MATERIAL		ANC			11-18-11

CATALOG NUMBER
A20807-1044LWA SHOWN

(MILLIMETER) INCH INITIAL RELEASE DRFT'R ANC 4-12-11 CHK'R MDW 4-12-11 APP MDW 4-12-11 E.O. NUMBER EO 3181-2	TOLERANCES - MACHINING UNLESS OTHERWISE NOTED BREAK EDGES MACH. .006/.016 FINISH SURFACES 125		THIRD ANGLE PROJECTION 	
	FRACTIONS ±1/64 DECIMALS 2 PL ±.025 3 PL ±.010 ANGLES ±1°		PURCH.	FINISH
			REF. NO.	SCALE
	MAT'L. DESCR. 16"-24" VERTICAL ADJUSTABLE INDICATOR POST ASSEMBLY WITH PVC LOWER BARREL		STK. NO.	NUMBER A20807

REVISION L
SHEET 1 OF 1